

Mounting Brackets for G.A.L. Hatch Switches

H-W supplies you with a complete line of mounting brackets for G.A.L. hatch switches. Functional design and aluminum construction make these brackets economical and lightweight. H-W supplies brackets and cams only. Switches and vanes can be ordered directly through G.A.L. Please note that these brackets are specifically designed for G.A.L. switches only. Mounting brackets are equipped with all necessary mounting hardware.

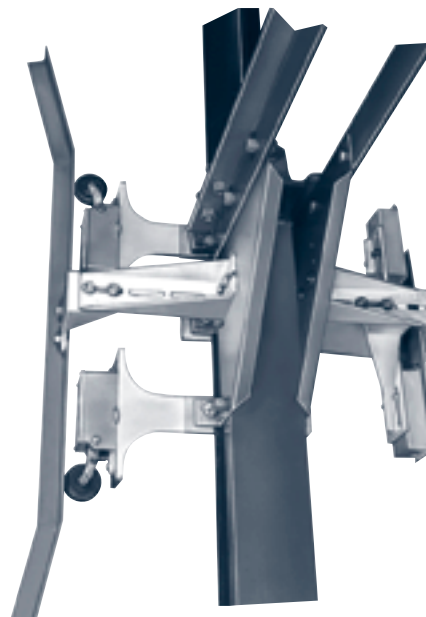

Adjustable Guide Rail Brackets

Heavy-duty guide rail brackets are designed to securely attach car and counterweight rails to the building structure. H-W supplies rail brackets with all necessary mounting hardware. Our engineers will provide you with custom designs to accommodate all bracket conditions except seismic zone 3 or greater or cornerpost car brackets.

Guide Rails

H-W supplies guide rails from the finest quality steel, machined to exacting tolerances. All rails from H-W are supplied with rail splice plates and bolts.

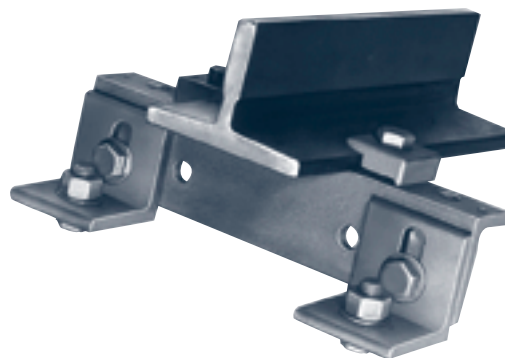

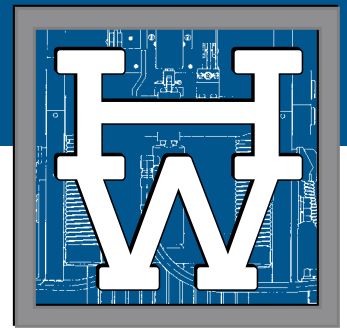

Hollister-Whitney Rope Shackles and Springs

Hollister-Whitney wedge type shackles are of one piece construction specifically designed for elevators and are available in 18", 24", 30", and 36" overall lengths for 3/8", 1/2", and 5/8" ropes. Equalizer springs are normally supplied for counterweight shackles only. Wedge shackles conform to New York City Housing Authority specifications and also have Material and Equipment Acceptance (MEA) approval from the City of New York Department of Buildings.

Hoist and Governor Ropes

H-W can supply you with special strength wire rope designed specifically for the requirements of your elevator. H-W recommends the use of 8 x 19, 21, or 25 traction steel.

Remember! When Ordering Limit or Leveling Brackets, Please Specify:

- Car Speed
- Type of Control
- Number of Landings
- Rail Size

When Ordering Rail Brackets, Please Specify:

- Rail size for Car or Counterweight
- Dimension from Back of Car Rail to Support
- Dimension from Centerline of Counterweight Rails to Support

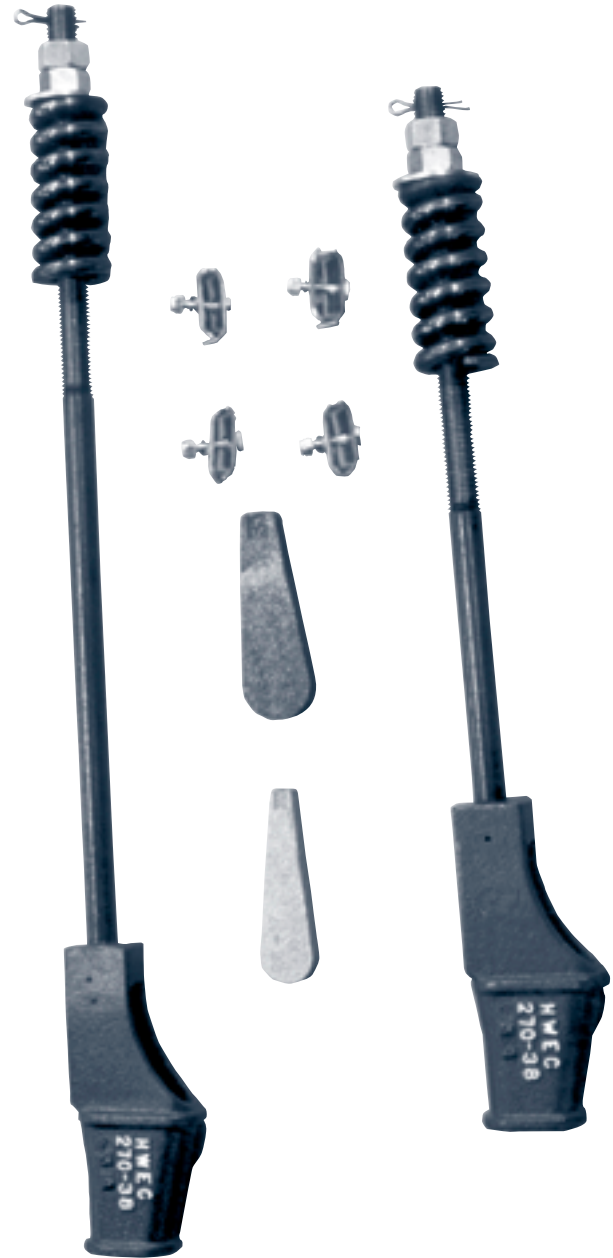

When Ordering Wedge Shackles, Please Specify:

- Rope Size
- Overall Length
- Quantity