

# OIL BUFFERS

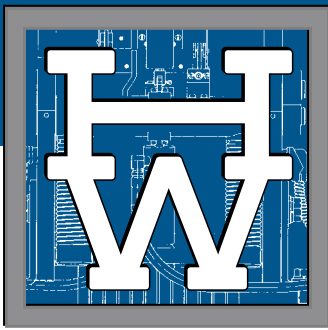

The Hollister-Whitney Series 500 Oil Buffers answer your need for easy-to-install, reliable, and rugged car and counterweight oil buffers. These buffers are readily mountable wherever reliable oil buffers are needed. Series 500 Oil Buffers are designed and built to strict engineering standards and conform to ASME A17.1 and C.S.A. B44 safety codes. They also conform to New York City Housing Authority specifications and have Material and Equipment Acceptance (MEA) approval from the City of New York Department of Buildings.

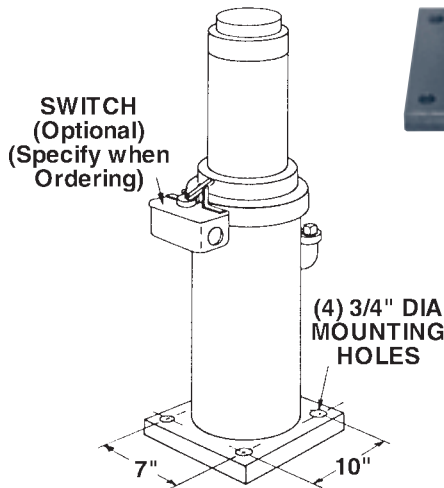

## When Ordering Oil Buffers, Please Specify the Following:

- Rated Car Speed
- Rated Car Capacity
- Empty Car Weight
- Total Counterweight Weight
- With or Without Switch
- If Car Buffer Strut is Required
- If Pit Channels are Required

ASSY. NO.	STROKE	OVERALL HEIGHT	COMP. HEIGHT	MAX. CAR SPEED	GROSS LOAD		SHIPPING WEIGHT
					MIN.	MAX.	
500	9"	30"	21"	350 FPM	2,500	15,000	150#
510	12"	37"	25"	400 FPM	2,500	15,000	180#
520	18"	50"	32"	500 FPM	3,000	12,000	210#
530	26"	70"	44"	600 FPM	3,000	12,000	270#
535	45"	117"	72"	800 FPM	3,000	12,000	390#

# SPRING BUFFERS

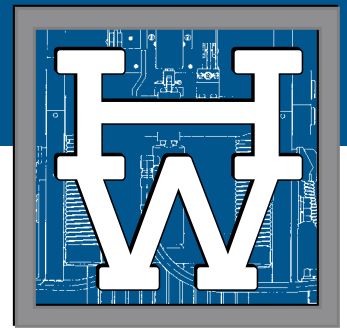

Car and Counterweight Spring Buffers from Hollister-Whitney are ruggedly built and designed to meet your specific requirements for 200 f.p.m. and below.

## When Ordering Spring Buffers, Please Specify the Following:

- Rated Car Speed
- Rated Car Capacity
- Empty Car Weight
- Total Counterweight Weight
- Overall Height of Buffer
- If Pit Channels are Required



CAR SPRING BUFFERS				
Gross Load (Lbs.) Min.-Max.	Spring No.	Qty.	Comp. (Ins.)	O.A. Spring Hgt. (Ins.)
3550 - 5300	400-8	2	5	15 3/4
5000 - 7500	400-37	2	5	17
6700 - 10000	400-38	2	5	19 1/2
8300 - 12400	400-55	2	4	19
10350 - 15500	400-55	2	5	19
13350 - 20000	400-38	4	5	19 1/2
16550 - 24800	400-55	4	4	19
20700 - 31000	400-55	4	5	19
31000 - 46500	400-55	6	5	19

COUNTERWEIGHT SPRING BUFFERS				
Gross Load (Lbs.) Min.-Max.	Spring No.	Qty.	Comp. (Ins.)	O.A. Spring Hgt. (Ins.)
1800 - 2650	400-8	1	5	15 3/4
2500 - 3750	400-37	1	5	17
3350 - 5000	400-38	1	5	19 1/2
4150 - 6200	400-55	1	4	19
5200 - 7750	400-55	1	5	19
6700 - 10000	400-38	2	5	19 1/2
8300 - 12400	400-55	2	4	19
10350 - 15500	400-55	2	5	19
15500 - 23250	400-55	3	5	19
20700 - 31000	400-55	4	5	19

**Note:** Min. O.A. Buffer Height = Spring Height + 1"