

BASEMENT SET TRACTION MACHINE DIMENSIONS

MACH.	BRAKE	A	B	C	D	E	F	H	J	K	L	M	N	R (DIA.)	
														MIN.	MAX.
#44 B.S.	#102 DISC	58 3/8	52	6	23 7/8	37 7/8	28 7/8	20	5	7 1/2	15 5/16	13 7/8	17 9/16	20	28
#43 B.S.	#90 DRUM	58 3/8	52	6	23 7/8	37 7/8	36 3/4	20	5	7 1/2	16 3/4	13 7/8	17 3/8	20	28
#54 B.S.	#102 DISC	63 1/4	58	6	26 3/4	41 3/4	30 5/8	23 3/4	6 1/4	9 1/2	15 5/8	14 3/4	17 3/4	20	30
#53 B.S.	#100 DRUM	63 1/4	58	6	26 3/4	41 3/4	39	23 3/4	6 1/4	9 1/2	19	14 3/4	19 9/16	20	30
#64 B.S.	#112 DISC	73 1/4	66	8	33 1/4	51 1/4	34 1/2	25 1/2	7 3/4	11	17 5/8	18 1/4	19 7/8	25	36
#63 B.S.	#110 DRUM	73 1/4	66	8	33 1/4	51 1/4	45	25 1/2	7 3/4	11	23 3/8	18 1/4	24 3/8	25	36
#74 B.S.	#120 DRUM	82 13/16	76	10	40 13/16	59 13/16	46 5/8	31 3/4	10	12 1/2	23 3/4	19 5/16	24 3/4	32	38

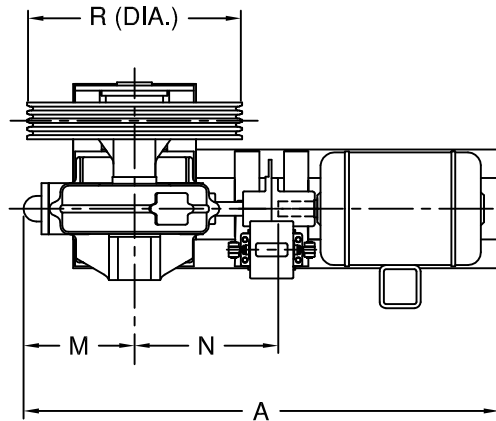

RIGHT HAND MACHINES SHOWN,
LEFT HAND MACHINE SYMMETRICALLY
OPPOSITE ABOUT ϕ OF TRACTION SHEAVE.

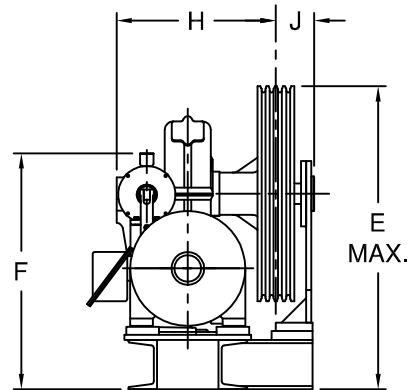
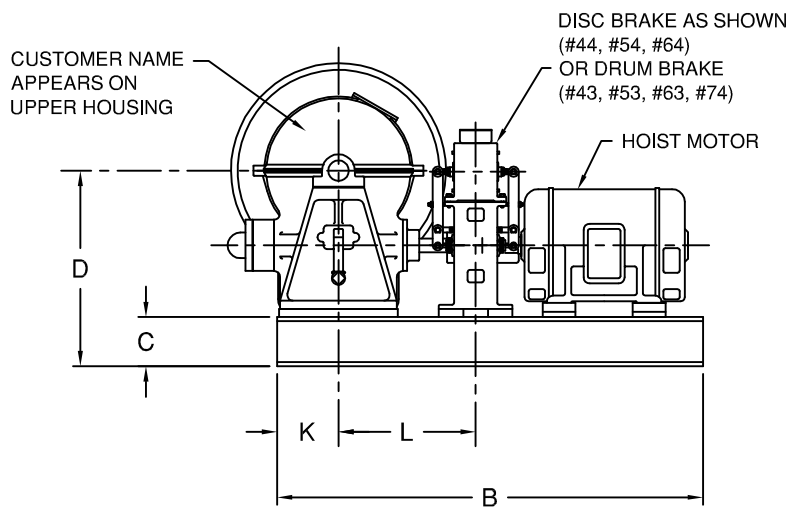

11-13-03



HOLLISTER-WHITNEY
ELEVATOR CORPORATION
QUINCY ILLINOIS

BASEMENT SET TRACTION
MACHINES

DIMENSIONAL
SHEET

1108

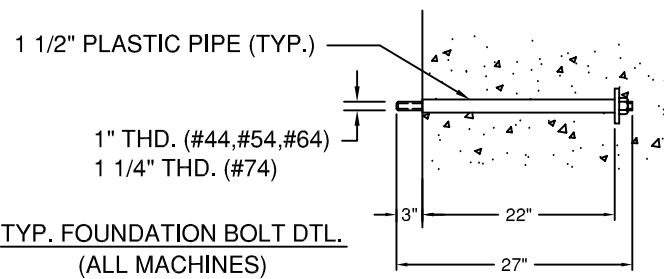
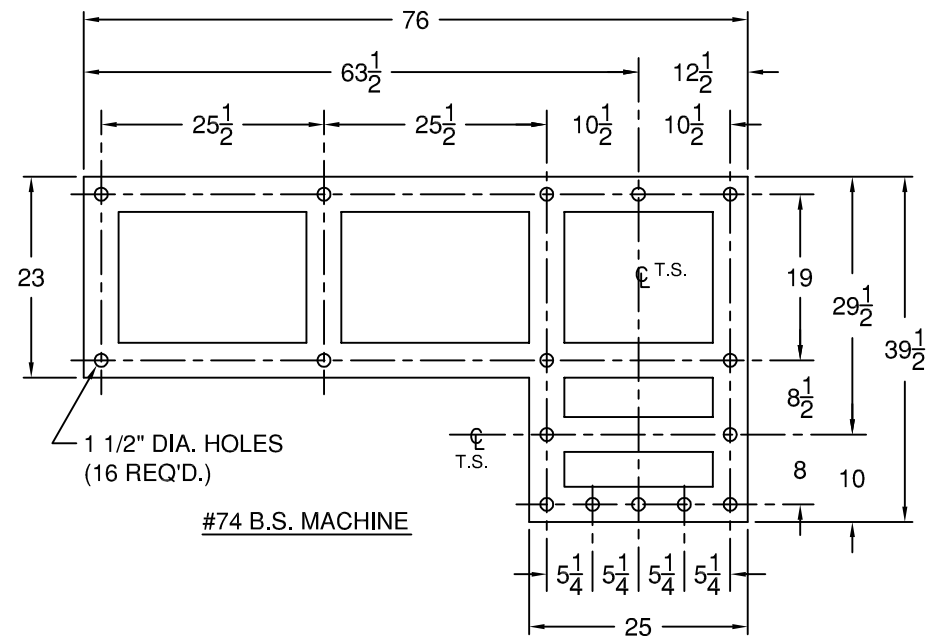
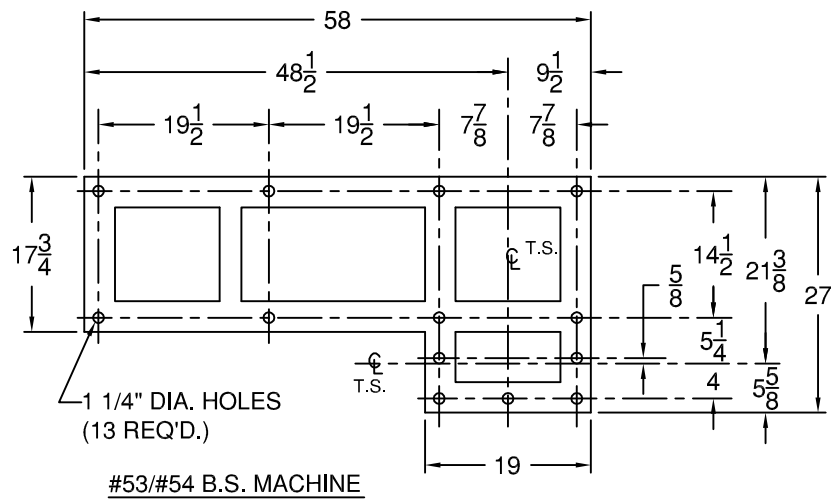
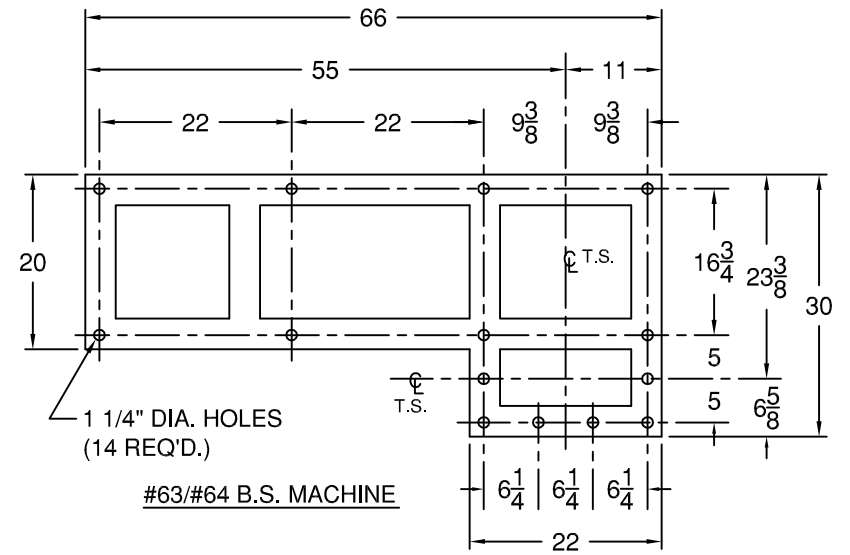
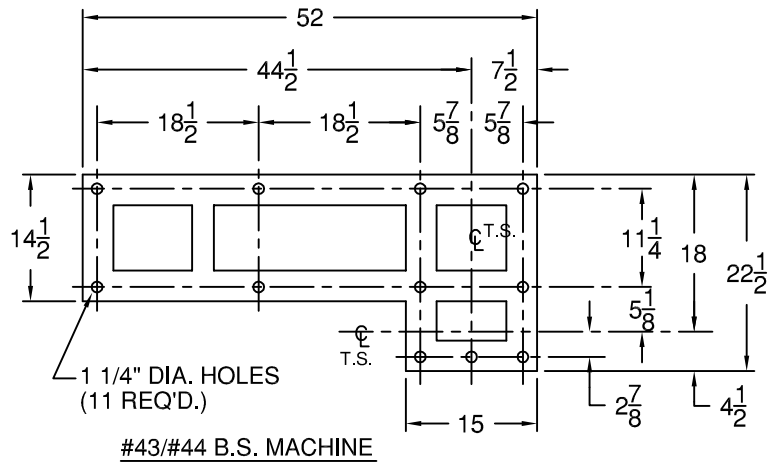

RIGHT HAND MACHINES SHOWN,
LEFT HAND MACHINE SYMMETRICALLY
OPPOSITE ABOUT Q OF TRACTION SHEAVE.