

SECTION "A-A"

SEE DTL. "1" FOR #34 MACH. ONLY

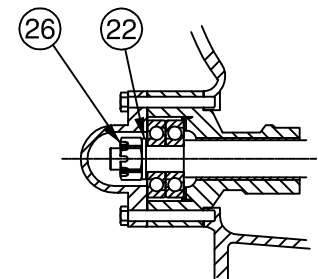

DETAIL "1"
(FOR #34 MACHINE ONLY)

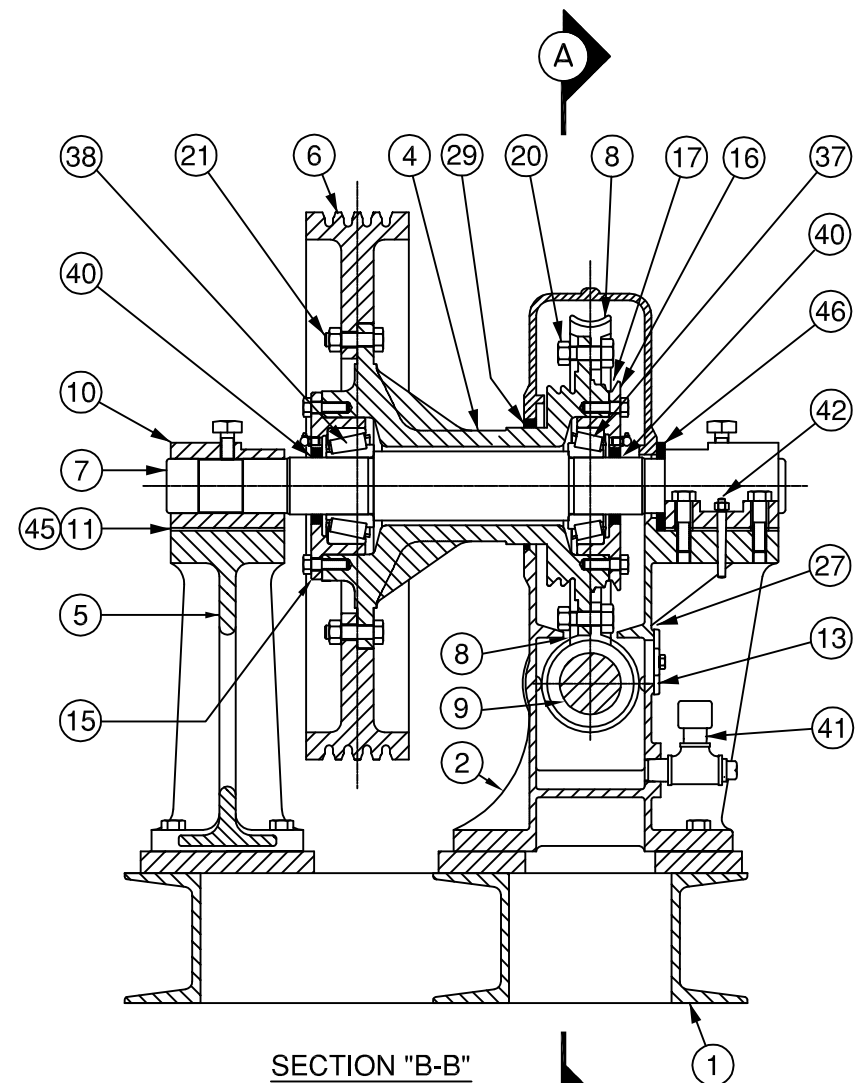

SECTION "B-B"

	HOLLISTER-WHITNEY ELEVATOR CORPORATION QUINCY ILLINOIS	
	OVERHEAD TRACTION MACHINES WITH DISC BRAKE	
PARTS LIST BULLETIN	1125-OH	

PUR #413 2-11-10

OVERHEAD TRACTION MACHINES WITH DISC BRAKE

PARTS LIST

NO.	DESCRIPTION	QTY.	PART NO.			
			#34 Mach.	#44 Mach.	#54 Mach.	#64 Mach.
1	BASE	1	34-OH-1	43-OH-1	53-OH-1	64-OH-1
2	HOUSING-LOWER	1	34-002	43-2	53-2	63-2
3	HOUSING-UPPER	1	34-003	43-3	53-3	63-3
4	CENTER-GEAR & T.S.	1	34-004	43-4	53-4	63-4
5	STAND-OUTBOARD	1	33-005	43-5	53-5	63-5
6	SHEAVE-TRACTION	1		43-	53-	63-
7	SHAFT-MAIN	1	34-018	43-18	53-18	63-18
8	GEAR	1	34-	43-	53-	63-
9	WORM	1	34-	43-	54-	64-
10	BLOCKS-SHAFT SUPPORT	2	33-061	43-61	53-61	63-61
11	SHIM-SHAFT SUPPORT BLOCK (SOLID)	8	34-062	43-62	53-62	63-62
	SHIM-SHAFT SUPPORT BLOCK (LAM.)	4	34-062-1	43-62-1	53-62-1	63-62-1
12	PLATE-UPPER HOUSING	1	43-63	43-63	43-63	74-63
13	PLATE-LOWER HOUSING	1	43-64	43-64	43-64	43-64
14	DISC-BRAKE	1	34-186	44-186	54-186	64-186
15	RETAINER-T.S. END BEARING	1	34-066	43-66	53-66	63-66
16	RETAINER-GEAR END BEARING	1	34-067	43-67	53-67	63-67
17	SHIM-RETAINER (GEAR END)		34-068	43-68	53-68	63-68
18	COUPLING-MOTOR	1	34-187	44-187	44-187	64-187
19	GASKET-HOUSING	2	34-071	43-71	53-71	63-71
20	BODY BOLT-GEAR END	6/8	43-175 (6)	43-72 (6)	53-72 (6)	53-72 (8)
21	BODY BOLT-T.S. END	8	43-73	43-73	53-73	53-73
22	WASHER	2/1	33-74 (2)	43-74 (1)	53-74 (1)	63-74 (1)
23	WASHER	1	————	44-199	54-199	64-199
24	NUT-JAM	2/3	34-075 (2)	43-075 (3)	53-075 (3)	63-075 (3)
25	COLLAR-THREADED LOCK	1	————	44-198	54-198	64-198
26	NUT-SLOTTED	1	34-76	————	————	————
27	GASKET-LOWER HOUSING PLATE	1	43-77	43-77	43-77	43-77
28	GASKET-UPPER HOUSING PLATE	1	43-78	43-78	43-78	74-78
29	SEAL-HOUSING	1	34-079	43-79	53-79	63-79
30	SEAL-CLIPPER (SPLIT)	1	34-081-1	43-81-1	53-81-1	63-81-1
31	BUSHING-WORM SHAFT	2	34-082	43-82	53-82	63-82
32	RETAINER-CLIPPER SEAL	1	34-083	43-83	53-83	63-83
33	HOUSING-REAR END BEARING	1	34-084	43-84	53-84	63-84
34	CAP-REAR END BEARING HOUSING	1	34-085	43-85	53-85	63-85
35	HOUSING-FORWARD END BEARING	1	34-086	43-86	53-86	63-86
36	SHIM-BEARING HOUSING	8	34-087	43-87	53-87	63-87
37	BEARING-GEAR END	1	34-089	43-89	53-89	63-89
38	BEARING-T.S. END	1	34-090	43-90	53-90	63-90
39	BEARING-THRUST(ONE MATCHED SET OF 2)	1	34-091	43-91	53-91	63-91
40	KLOZURE (GEAR & T.S. END)	2	34-092	43-92	53-92	63-92
41	OIL LEVEL TUBE	1	43-101	43-101	63-101	53-101
42	PIN-THREADED DOWEL #7 (3" LG.) / #10 (5" LG.)	9	43-102	43-102	43-102	74-102
43	KEY-BRAKE DRUM	1	43-104	43-104	43-104	63-104
44	TAG-MACHINE DATA	1	43-134	43-134	43-134	43-134
45	SHIM-SUPPORT BLOCK	1	34-157	43-157	53-157	63-157
46	FOAM SEAL-GEAR HOUSING	1	34-178	43-178	53-178	63-178
47	BRAKE - DISC	1	92	102	102	112