

HOLLISTER-WHITNEY “ROPE GRIPPER™”

Instructions for Model #620GA1, 620GA2
(US PATENT 8,511,437)

WARNING: KEEP HANDS CLEAR OF “ROPE GRIPPER™”.
FORCES CREATED CAN CRUSH FINGERS.

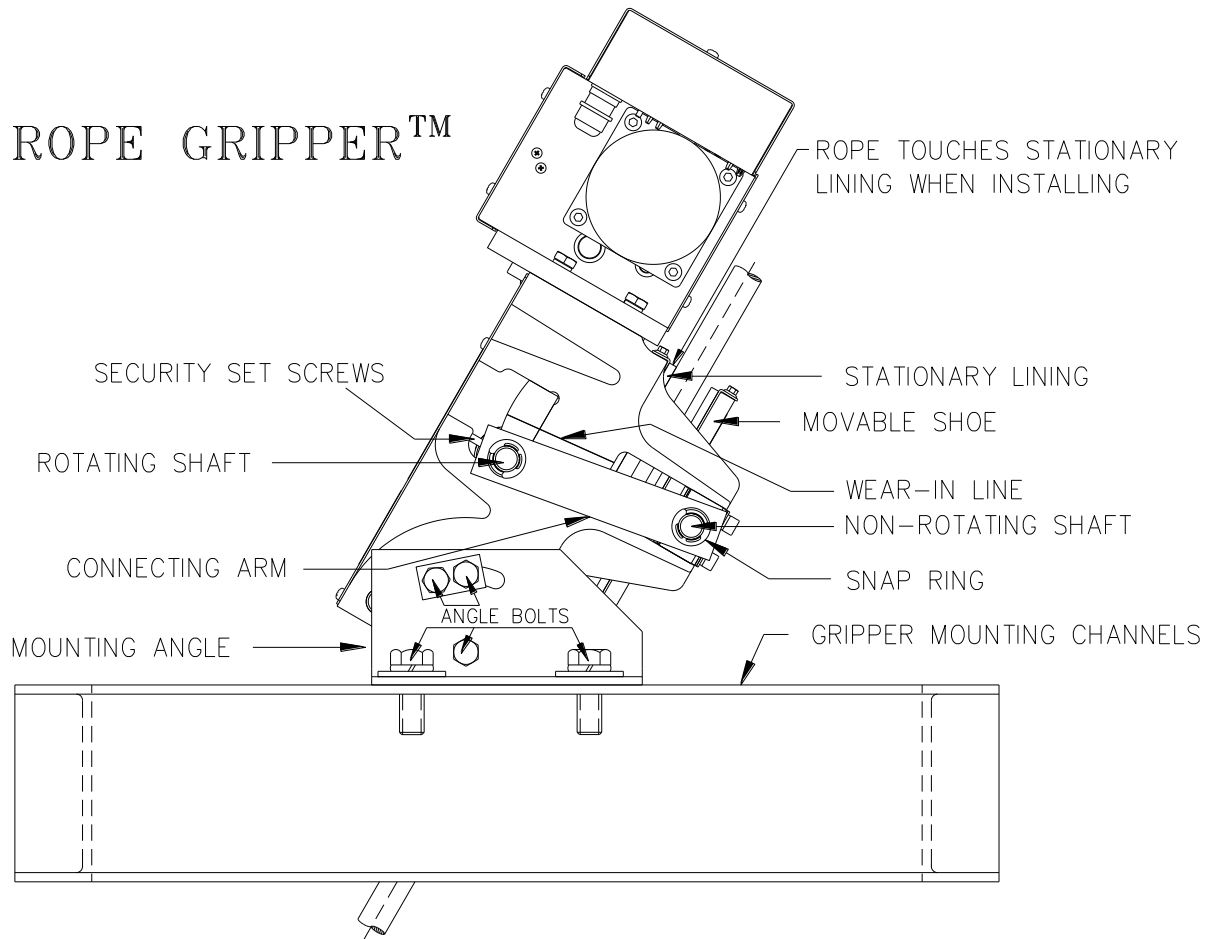

Figure 1

“ROPE GRIPPER™” MOUNTING CHANNELS GUIDELINES

- The Mounting Channel Framework supporting the “ROPE GRIPPER™” must withstand upward and downward forces according to Table 1 below and applicable code requirements.
- The Mounting Channel Framework must be sufficiently sized to securely hold the “ROPE GRIPPER™” and elevator while preventing any sliding. The Traction Machine must also be prevented from sliding. See Figure 2 and Figure 3 for suggested mountings.
- When adding a “ROPE GRIPPER™” to an existing installation, it may not be possible to mount the gripper in the machine room. It is acceptable to mount the gripper horizontally or upside down, as long as proper consideration for access is given for future gripper maintenance and opening the gripper manually.

Typical Mounting Arrangement for Overhead Machines - New Installations -

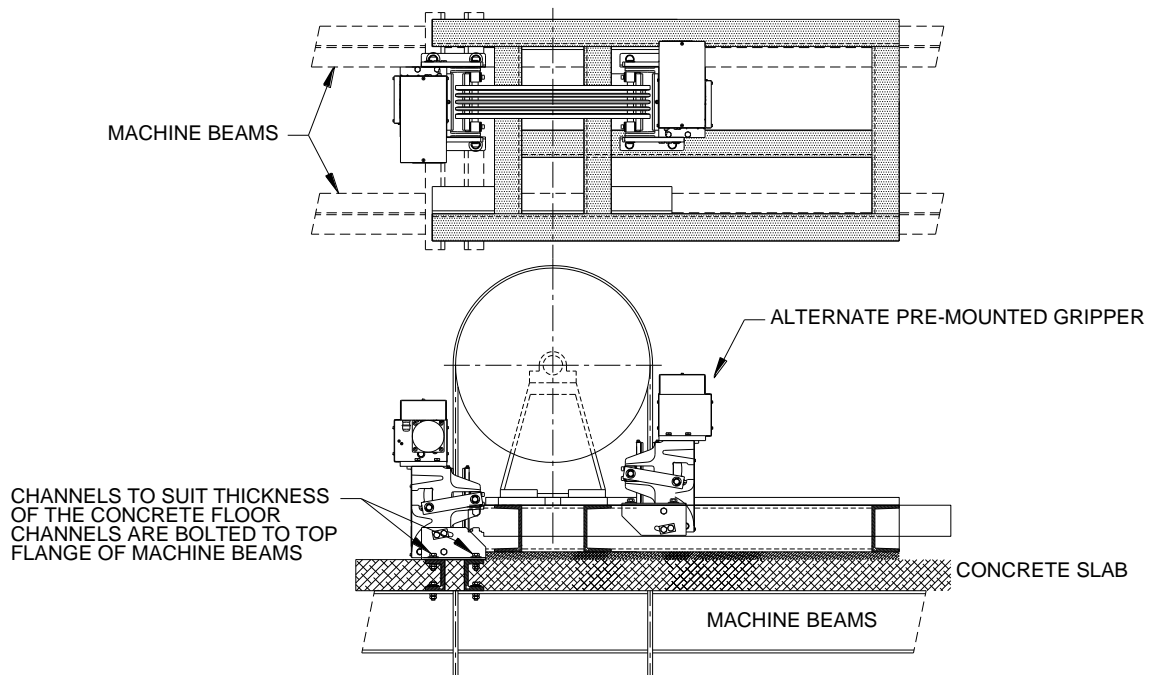
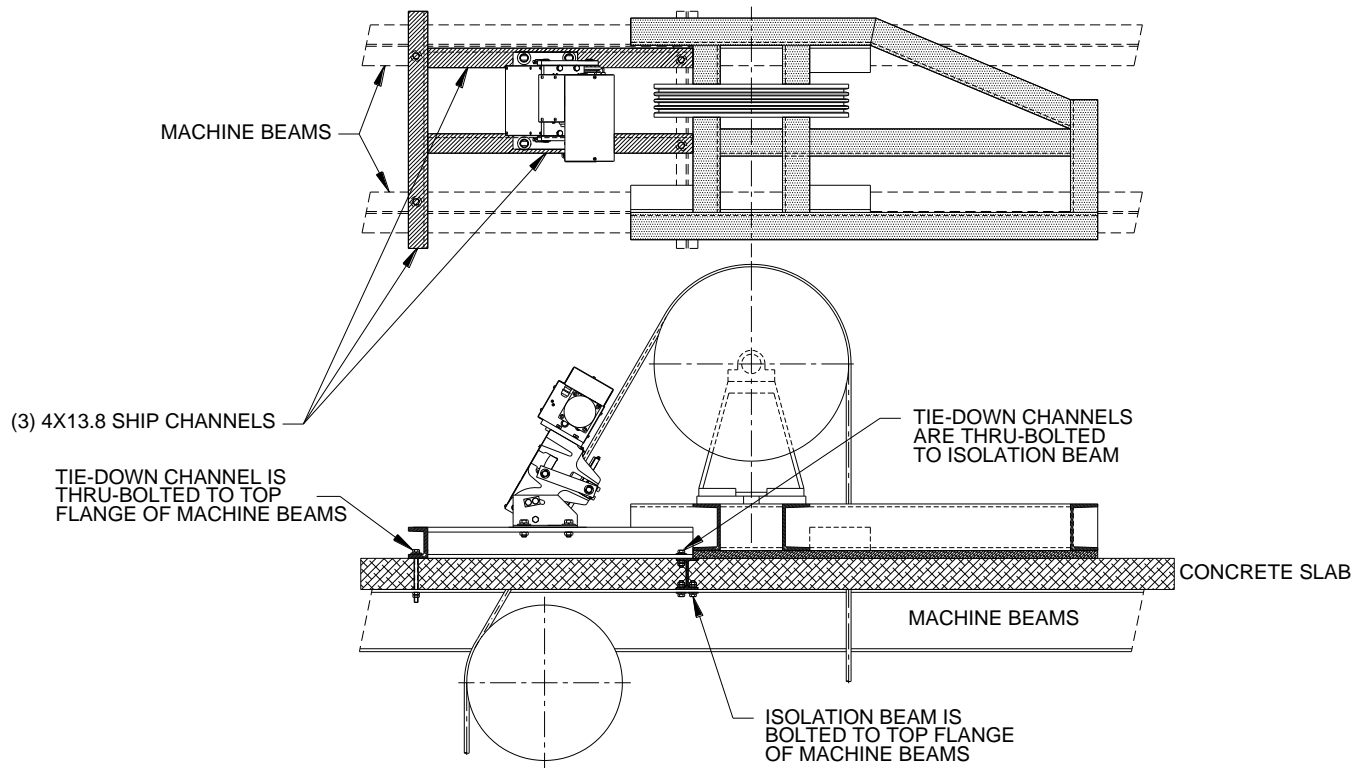

Figure 2

Typical Mounting Arrangement for Overhead Machines
 - Existing Installations -

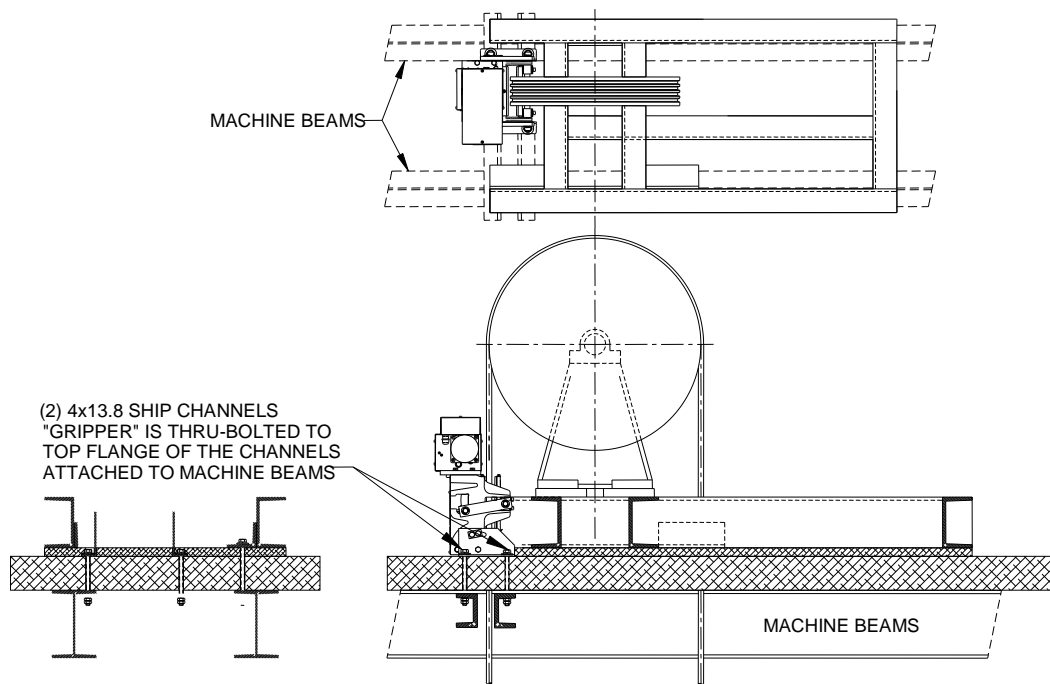
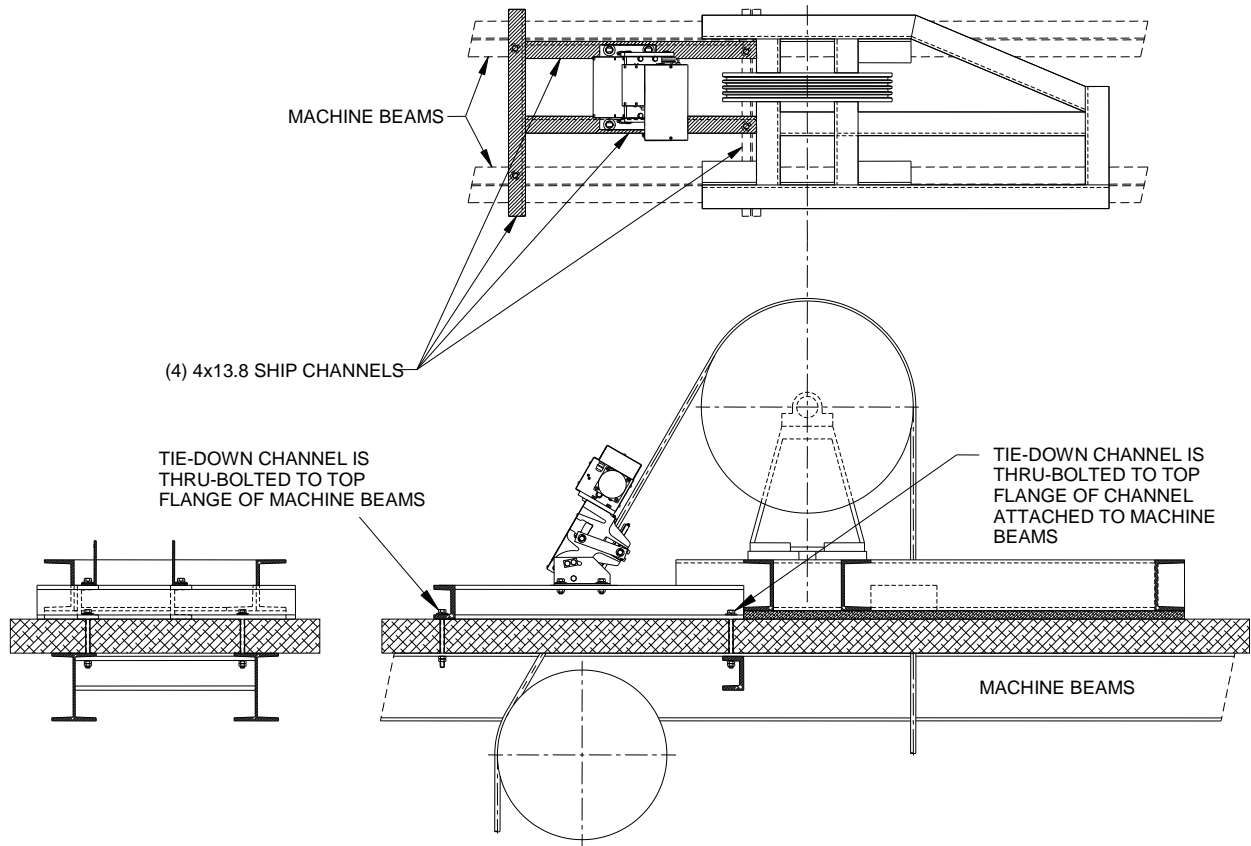

Figure 3

INSTALLATION OF “ROPE GRIPPER™”

- Be sure security set screws are holding the rotating shaft in the LOADED (open) position as shown in Figure 1 above.
- Remove both connecting arms after removing the four retaining rings.
- Remove movable shoe assembly.
- Attach “ROPE GRIPPER™” to mounting channels with appropriate bolts per Table 1 below. Do not fully tighten bolts yet.

MODEL #	APPROXIMATE UP & DOWN FORCE	MOUNTING BOLTS (Approximate Torques)	REFERENCE DRAWINGS
620G (using inch hardware)	2000 lbs	GRADE 5: 1/2" UNC @ 74 ft-lbs	620-DIM
620G (using metric hardware)	907 N	GRADE 8.8: M12 @ 96 N*m	620-DIM

Table 1

Note: Mounting must conform to applicable codes.

- Position the “ROPE GRIPPER™” so that the stationary shoe lining barely touches the ropes from top to bottom. Make sure “ROPE GRIPPER™” is squarely aligned, and centered side to side as much as possible, with the ropes. Misalignment may cause uneven and/or excessive lining wear.
- Securely fasten “ROPE GRIPPER™” mounting bolts (5 bolts per side). Make sure they are torqued correctly. See Table 1.
- Double check rope alignment. Make sure the ropes touch the stationary shoe lining evenly.
- Reinstall movable shoe assembly.
- Reinstall connecting arms with chamfered edges facing the inside of the gripper and secure the four retaining rings.
- Remove upper cover. Install proper fitting with power and control wiring. See Figure 9.
- Connect terminals RG1, RG2, RG5 and RG7 to elevator control. Check control diagram for proper connection. Connect the Earth ground to the green grounding screw located in the electrical enclosure. See Figure 9.
- Make sure controller safety circuit is active and clear for running. Turn test switch ON. Motor may run momentarily, and solenoid will energize, causing the pawl to engage the gear.
- When the solenoid is energized, loosen the two security set screws a turn or two. Confirm that the “ROPE GRIPPER™” is being held open by the pawl.
- Remove security set screws. *Once removed, store set screws in the two threaded holes provided in the gearbox base plate.*

NOTE: Security set screws must be completely removed when “ROPE GRIPPER™” activates to prevent gripper failing to set or damage to the unit.

- Unit is now ready for required testing and lining wear-in.

TESTING OF “ROPE GRIPPER™”

- Make sure controller safety circuit is active and clear for running. Turn test switch ON (see Figure 8). The “ROPE GRIPPER™” should be in or go to the ready, open (LOADED) position (NOT clamping the ropes).
- Turn test switch to OFF. This should activate the “ROPE GRIPPER™”, clamping the ropes. Be sure that while clamping the ropes, the Elevator Can Run switch (see Figure 4) contacts on the “ROPE GRIPPER™” stop or prevent power from being applied to the motor and machine brake.
- Turn test switch ON. “ROPE GRIPPER™” should reload (re-open).

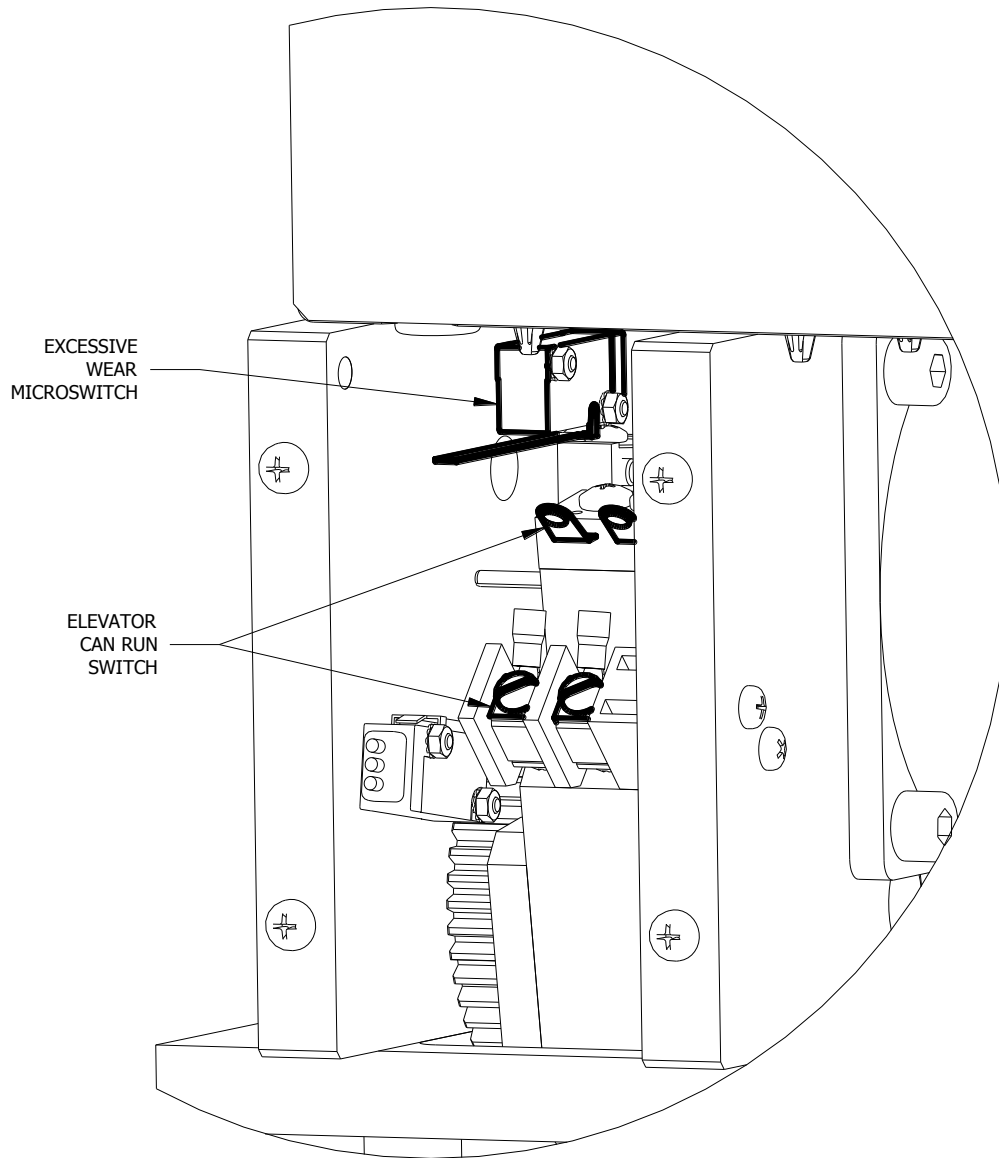

Figure 4

“ROPE GRIPPER™” LINING WEAR-IN

A line has been marked on the side wall of the gripper to aid in the Wear-In process. Note that at this point in the procedure, this line is well *above* the Connecting Arm and will be met or covered by the Connecting Arm during the Wear-In process (see Figure 1 for locations of Connecting Arm and Wear-In Line).

- Make sure test switch is ON.
- Run the car at the slow or inspect speed. Keeping hands clear of all equipment use caution to wipe down the ropes to remove any dirt and/or excess oil and grease from top to bottom.
- Jump terminals RG5 to RG7, preferably at the controller, and run the empty car in slow speed in the direction that the machine will pull the ropes thru the “ROPE GRIPPER™” (typically DOWN). When the car is up to that speed, turn the test switch OFF. The “ROPE GRIPPER™” will clamp the ropes with a light pressure and ropes will begin to wear grooves in the linings.

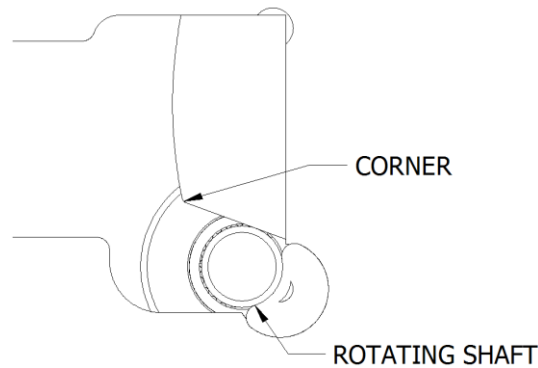

Figure 5

- As the linings wear in, the rotating shaft will move up the cam slot and around the corner of the cam noted above (Figure 5), and the connecting arms (see Figure 1) will move up the side wall and begin to match or line up with the wear-in line marked on the side wall.
- *Note that it may take several car runs to complete lining wear-in.*
- Once the rotating shaft has turned the corner and the wear-in line is matched or covered, stop the car and **REMOVE THE JUMPER FROM RG5 TO RG7. Failure to remove the jumper will cause unsafe conditions.**
- If the lining wear-in is not completed after the grooves in the linings have reached approximately 1/16" (1.5 mm) deep, spacer shims (Figure 6) can be moved from between the shaft support blocks and moveable shoe to the outside of the support block to allow the rotating shaft to just turn the corner and move up the cam to near the wear-in line. Refer to Table 2 for initial spacer and shim set-up. **Note: Before changing spacers, install security set screws to prevent unintended "ROPE GRIPPER™" activation, which could lead to severe personal injury and/or damage to the unit.**

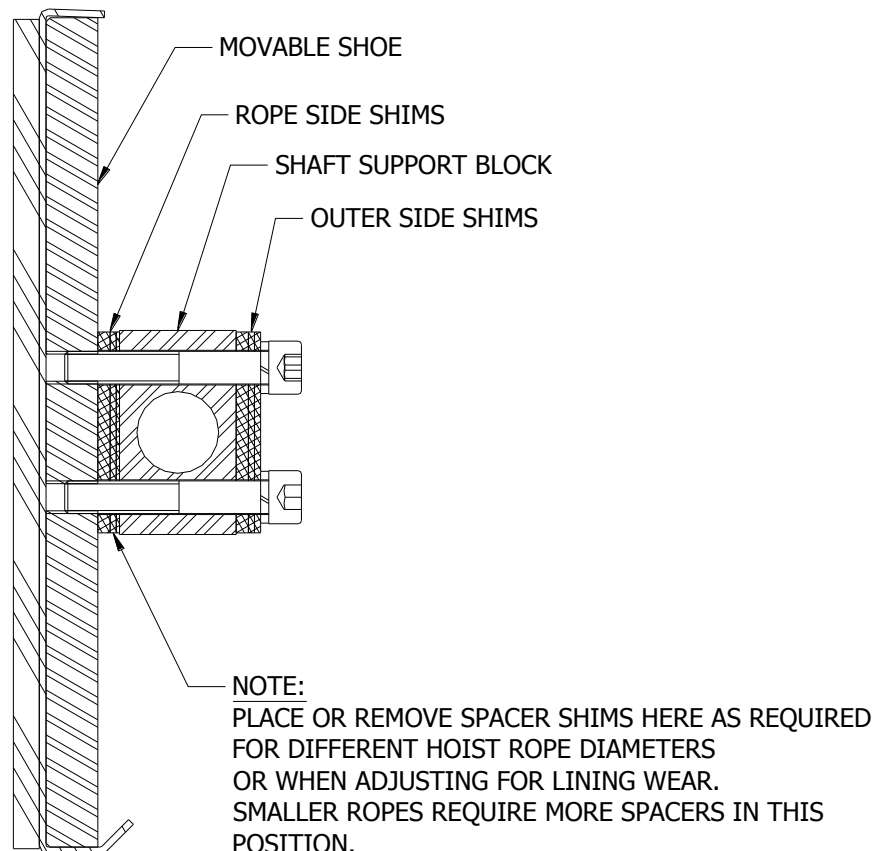

Figure 6

Rope Size			# of 3 mm	# of 1.5 mm	# of 0.8 mm	# of 3 mm	# of 1.5 mm	# of 0.8 mm
<u>mm</u>	<u>Inches</u>	<u>mm</u>	Shims on Rope Side Between Block & Shoe			Shims on Outside (back) of Block		
6		6.00	2	2	1	0	1	0
	1/4	6.35	2	2	0	0	1	1
7		7.00	2	1	1	0	2	0
	5/16	7.94	2	1	0	0	2	1
8		8.00	2	1	0	0	2	1
9		9.00	2	0	1	0	3	0
	3/8	9.53	2	0	0	0	3	1
10		10.00	1	1	1	1	2	0
11		11.00	1	1	0	1	2	1
	7/16	11.11	1	1	0	1	2	1
12		12.00	1	0	1	1	3	0
	1/2	12.70	1	0	0	1	3	1
13		13.00	0	1	1	2	2	0
14		14.00	0	1	0	2	2	1
	9/16	14.29	0	1	0	2	2	1
15		15.00	0	0	1	2	3	0
	5/8	15.88	0	0	0	2	3	1
16		16.00	0	0	0	2	3	1

Table 2

LINING REPLACEMENT or SHIM ADJUSTMENT

- The linings will wear, especially after multiple high-speed stops. When clamping, the rotating shaft will move towards the upper end of the cam as the linings wear. Near the end of the cam, the excessive wear microswitch (see Figure 4) will open and the “ROPE GRIPPER™” will not automatically reopen (reload).
- In this case you must inspect the linings, and decide whether the spacer shims should be adjusted, or the linings should be replaced. This will depend on whether the grooves in the linings are more or less than 3/16” (4.75mm) deep. To inspect linings for wear, first reopen the “ROPE GRIPPER™” using Method 1 or 2.
 1. Turn test switch off. On PC Board, move jumper J5 to J3. Turn test switch on; gripper will reload electrically. Once in the open position, install the security set screws so they touch the rotating shaft. Return jumper on J3 to J5. Or;
 2. Turn test switch off. Use the supplied 6 mm socket wrench on either of the hex shaft ends on the side of the gear housing. **IMPORTANT:** Use wrench to open gripper only as far as is necessary to install security set screws. Opening gripper further with socket wrench will damage gripper. Once in the open position, install the security set screws so they touch the rotating shaft.

Note: Before changing shoes or spacers, install security set screws to prevent unintended “ROPE GRIPPER™” activation, leading to severe personal injury and/or damage to the unit.

- **If lining wear is excessive**, greater than 3/16” (4.75 mm), linings should be replaced. Remove both connecting arms by removing 4 retaining rings. Remove moveable shoe assembly. Remove screw from top of each lining assembly and remove linings by unhooking them at the bottoms. It may be necessary to loosen 3 mounting bolts per side to tip gripper to allow access to stationary shoe. Refer to Table 2 for initial spacer and shim set-up to use with new linings. When linings have been replaced, follow the INSTALLATION OF “ROPE GRIPPER™” procedure and the LINING WEAR-IN procedure.
- **If lining wear is not excessive**, less than 3/16” (4.75 mm), spacer shims (Figure 6) can be moved from the back side of the shaft support blocks to between the shaft support blocks and moveable shoe. Remove the bolts that hold the blocks to the movable shoe, move the spacer shims to under the blocks and reinstall and tighten bolts. Addition of shims between the block and the shoe will lower the position of the rotating shaft toward the bottom end of the cam when clamping.
- When adjustment/replacement is complete, turn the test switch ON and carefully remove the security set screws, being sure the solenoid holds. Follow the procedures described earlier to ensure that the rotating shaft will be around the corner at the bottom of the cam (and connecting arm position matches or covers the wear-in line marked on the side wall) when gripping the ropes.

TESTING ALL CIRCUITS

The following three tests should be made while the car is running in slow speed in both the up and down directions.

- During each test the “ROPE GRIPPER™” should:
 - A. Grab the Ropes.
 - B. Stop the car, and
 - C. Open the control safety circuits disconnecting power to the motor and machine brake.
 - 1) Turn the “ROPE GRIPPER™” test switch OFF. Observe A, B, and C above.
 - 2) With the car in the door zone, open the door or open the door lock circuit, then open the door zone circuit, and observe A, B, and C above. **NOTE:** The controller’s safety circuits should require a manual reset before the “ROPE GRIPPER™” reopens.
 - 3) Manually open the governor overspeed switch and observe A, B, and C above. **NOTE:** The governor will require a manual reset after this test. The controller’s safety circuits should then require a manual reset before the “ROPE GRIPPER™” reopens.

SUGGESTED CONTROLLER CIRCUITS

NOTE: The following describes circuits to meet code requirements and prevent nuisance shutdowns. The controls circuit can also be configured so that the Rope Gripper also responds to other errors.

- Both the B44 and A17.1-2000 Codes and more recent codes require new circuitry for activation of the “ROPE GRIPPER™”. It is the controller manufacturer’s responsibility to provide proper circuitry that meets all applicable codes and laws for operating this device.
- The function of the “ROPE GRIPPER™” when applied is to clamp the ropes and stop the car. We recommend that the “ROPE GRIPPER™” is activated when an overspeed occurs or when the car leaves the floor (door zone) with the doors open (hoistway door unlocked and/or the car gate switch open). If the doors happen to open while the car is between floors, the “ROPE GRIPPER™” need not be activated.
- It is suggested that a manual reset of the Rope Gripper require a minimum of 10 seconds of constant pressure activation, to allow the mechanic resetting the Rope Gripper to quickly react to an unsafe condition. In other words, it is recommended that the reset control act as a

constant pressure switch for the first ten seconds, before latching in the run condition after ten seconds.

- It is suggested that if the elevator controller has a monitor function for the machine brake, that the rope gripper be activated immediately on sensing a stuck brake condition, rather than waiting for unintended motion to occur.
- The suggested circuits shown in Diagram 1 & Diagram 2 activate the “ROPE GRIPPER™” by opening contacts RG1, RG2, DZ1, and DZ2. Relay coils RG1, RG2, DZ1 and DZ2 are controlled by the Governor overspeed switch (GOS) and function blocks GRC1, GRC2, DZC1, and DZC2, respectively.

GRC1 DESCRIPTION

- If the car is not in the door zone when main line power turns “ON”, or when switching from “Inspection” to “Normal Operation”, or when resetting the Governor overspeed switch; allow a time interval, signal the door closure, and when the car gate or door interlock contact makes, energize RG1.
- Anytime the car is in the door zone (“Inspection” or “Normal Operation”), RG1 is de-energized when both the car gate contact and door interlock contact are opened. Should the car now leave the door zone (unintended motion), power to the “ROPE GRIPPER™” is removed and the “ROPE GRIPPER™” is activated. In the door zone, when the car gate contact or door interlock contact is made, energize RG1. If the car should leave the door zone with RG1 energized then “ROPE GRIPPER™” activation is prevented. RG1 should remain energized even if both the car and hoistway doors are opened while between floors. When the car is in the door zone again, RG1 should function as above.

GRC2 DESCRIPTION

Redundant circuits are required by the 2000 A17.1 and B44 Codes. Circuits for RG2 function identical to RG1 except separate logic for the timing function, door locks, gate switch and door zone should be used. DZC1 logic could be used for circuits of RG1 and DZC2 for circuits of RG2. (See NOTE in Diagram 3)

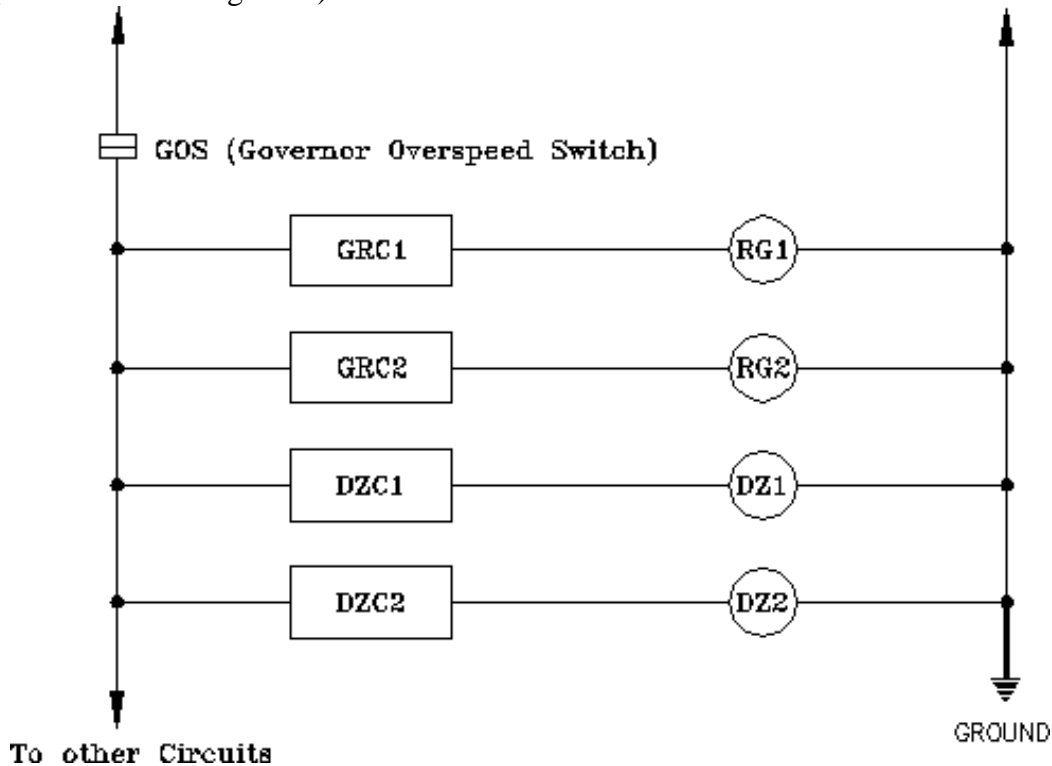
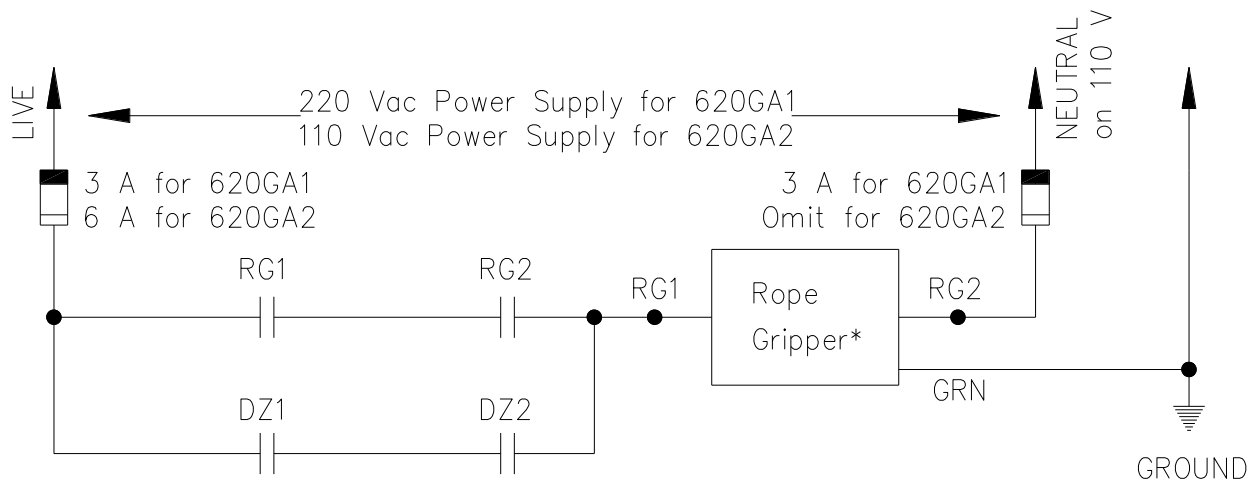

Diagram 1



*See Diagram 4 for Rope Gripper circuits

Diagram 2

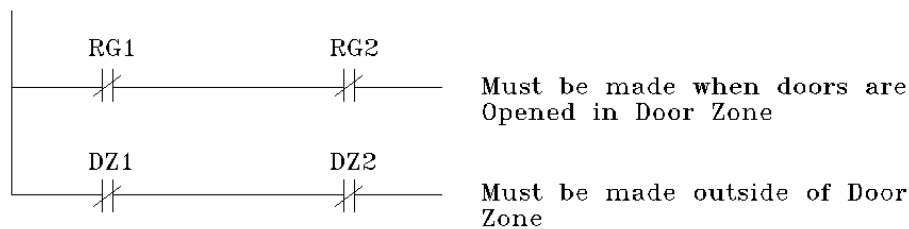

Diagram 3

NOTE: If force guided relays are used for RG1, RG2, DZ1, and DZ2, use this diagram.

DZC1 DESCRIPTION

- DZ1 is energized in the door zone and de-energized outside of the door zone (See Diagram 3 NOTE). Maximum door zone is 10"

DZC2 DESCRIPTION

- Circuits for DZ2 function are identical to DZ1 except a separate door zone signal is utilized. If the above circuits (Diagram 3) do not make contact when required, the elevator must be prevented from running. If other types of relays are used, circuits must prove that contacts from RG1, RG2, DZ1 and DZ2 are functioning properly and when a failure is detected the elevator must be prevented from running.

HOLLISTER-WHITNEY “ROPE GRIPPER™” OPERATION

NORMAL OPERATION

- Power to the “ROPE GRIPPER™” is constantly maintained. When in the door zone DZ1 and DZ2 provide power to the “ROPE GRIPPER™”. RG1 and RG2 energize when the doors close. As the car leaves the floor DZ1 and DZ2 de-energize, power to the “ROPE GRIPPER™” is maintained through RG1 and RG2. When approaching a new floor DZ1 and DZ2 again energize, when the doors open RG1 and RG2 de-energize.

OVERSPEED

- When an overspeed is detected, the Governor overspeed switch opens, additional overspeed can be detected by use of an encoder or tachometer that detects the speed of the elevator. (Not the motor or worm shaft of a geared elevator.) When detected, relays RG1, RG2, DZ1 and DZ2 de-energize. This removes power from the “ROPE GRIPPER™”, clamping the ropes and stopping the car.

OVERSPEED RESET

- Overspeed reset is accomplished by resetting the Governor overspeed switch and the elevator control circuits. Refer to and follow the controller manufacturer's instructions for "ROPE GRIPPER™" reset.

IMPORTANT: The code requires that the "ROPE GRIPPER™" be manually reset if it is triggered by fault. It is intended that a qualified technician inspect for and correct any malfunction before the car is placed back into service. A dangerous situation can be produced if a "ROPE GRIPPER™" is manually reset without first correcting the cause of the fault. E.g.: If there has been a brake failure that has not been corrected, when the "ROPE GRIPPER™" is reset, it is very likely that the car will fall either up or down.

UNINTENDED MOTION

- When at the floor with the doors open, relays RG1 and RG2 are de-energized and relays DZ1 and DZ2 are energized. If the car leaves the floor, DZ1 and DZ2 de-energize, removing power from the "ROPE GRIPPER™", clamping the ropes and stopping the car.

UNINTENDED MOTION RESET

- Unintended motion reset is accomplished through elevator control circuits. Refer to and follow the control manufacturer's instructions for "ROPE GRIPPER™" reset.

IMPORTANT: The code requires that the "ROPE GRIPPER™" be manually reset if it is triggered by fault. It is intended that a qualified technician inspect for and correct any malfunction before the car is placed back into service. A dangerous situation can be produced if a "ROPE GRIPPER™" is manually reset without first correcting the cause of the fault. E.g. if there has been a brake failure that has not been corrected, when the "ROPE GRIPPER™" is reset, it is very likely that the car will fall either up or down.

MANUAL OPENING

- During a power failure the "ROPE GRIPPER™" will activate. When power is restored the "ROPE GRIPPER™" will automatically reload and put the elevator back into service.
- If the car is to be moved during a power outage, manually open the "ROPE GRIPPER™" as follows:
 1. Confirm power switch to OFF.
 2. Assuming machine brake is functioning properly (preventing car movement), place the supplied 6 mm socket wrench on the upper or lower hex shaft end on the side of the gearbox. See Figure 7. Turn the wrench in the direction shown in Figure 8 for the respective hex shaft until the brake is loosened on the ropes and the car is free to move. (Note: A right-hand gripper is illustrated in Figures 7 & 8. For a left-hand Rope Gripper™, turn the wrench in the opposite direction from the illustration.)

IMPORTANT: Use wrench to open gripper only as far as is necessary to allow car movement. Opening further may damage the gripper.
 3. Place the wrench pin into the side of the Rope Gripper. Slowly let the wrench run backwards until the wrench handle is resting on the wrench pin. See Figure 8.
 4. To manually close the gripper, turn the wrench a little so that it is free of the wrench pin, remove the wrench pin, and then slowly and carefully guide the wrench to allow the gripper to return to the closed position.

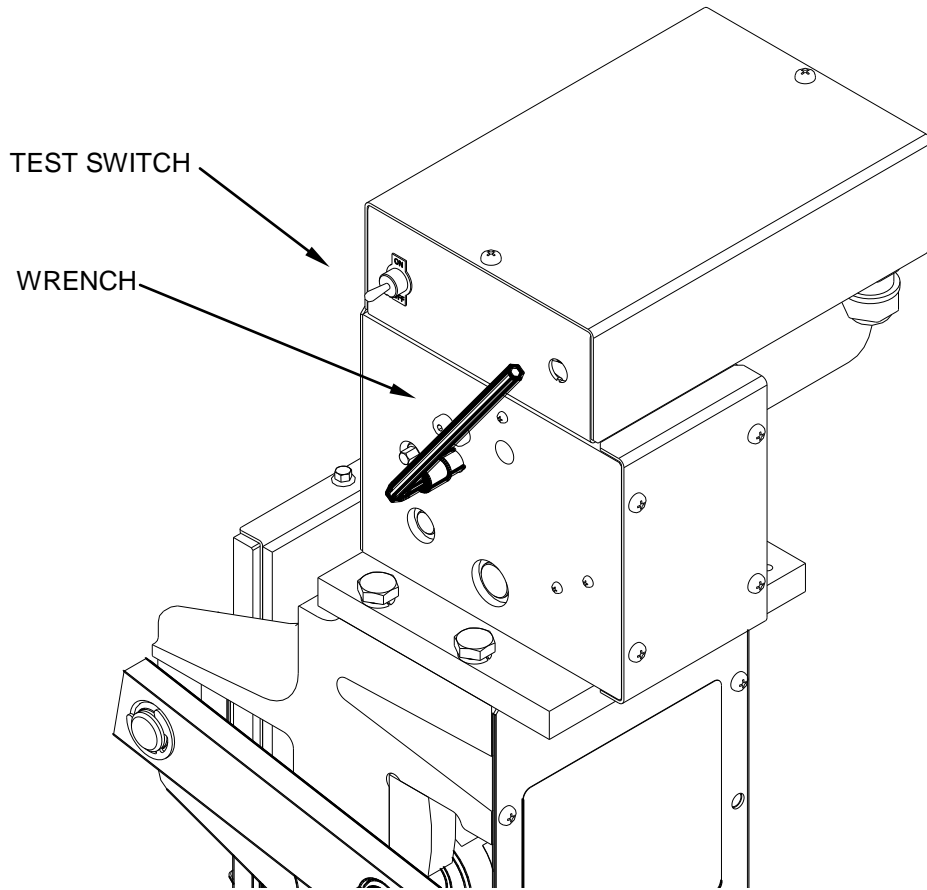

Figure 7 (RH unit shown; LH opposite)

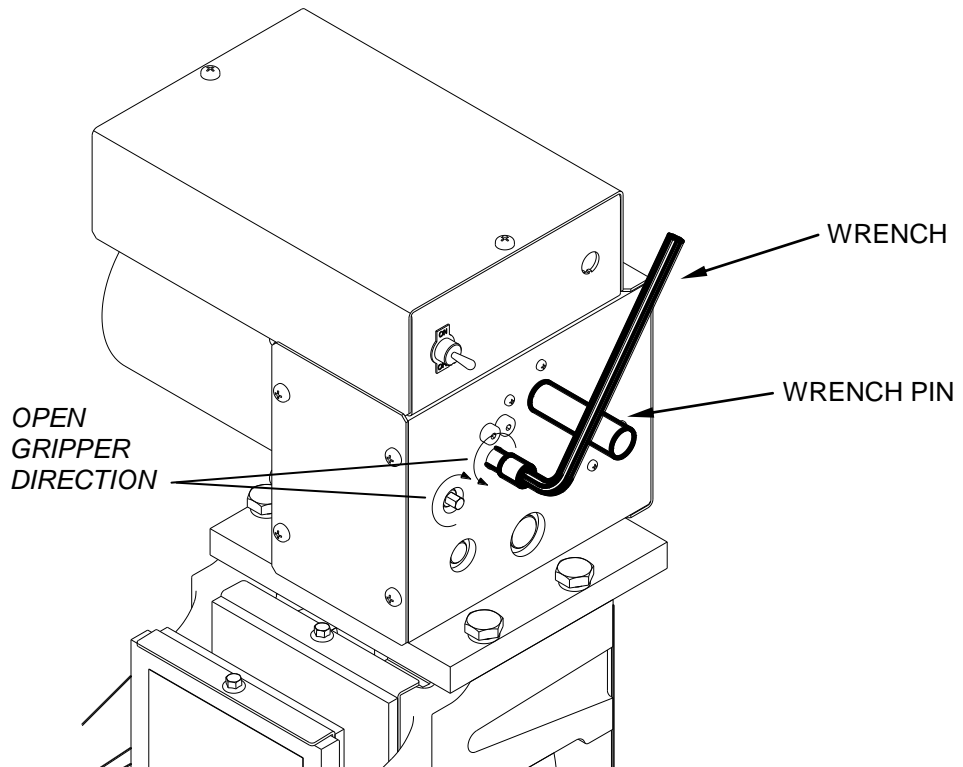

Figure 8 (RH unit shown; LH opposite)

**TEST PROCEDURE FOR COMPLIANCE WITH
CANADIAN CAN/CSA B44 AND ASME A17.1-2000, & EN81
SAFETY CODE FOR ELEVATORS**

1) POWER INTERRUPTION TEST

Run the car in slow speed and turn the test switch on the side of the unit to OFF. This will activate the “ROPE GRIPPER™” causing it to clamp the ropes and stop the car. When the “ROPE GRIPPER™” is activated, the “ELEVATOR CAN RUN” contacts will open and signal the controls to interrupt power to the driving motor and machine brake.

2) ASCENDING CAR OVERSPEED TEST

With an empty car, overspeed the car in the “UP” direction while keeping the machine brake open. The Governor overspeed switch will activate the “ROPE GRIPPER™”. The “ROPE GRIPPER™” will stop the car before the counterweight strikes the buffer or, at least, reduce the car speed to the speed for which the buffer is designed. If it is impractical to overspeed the car, run the empty car up at high speed with the machine brake held open and manually trip the Governor overspeed switch. The “ROPE GRIPPER™” will cause the car to slow down and stop. The Governor can then be tested to make sure the Governor switch opens at the correct overspeed setting.

3) UNCONTROLLED LOW SPEED TEST

**CAUTION: DO NOT ALLOW ANYONE TO ENTER
THE ELEVATOR DURING THIS TEST!!!**

With the car level at any floor and the door open, open the machine brake. (With empty car the elevator moves up, with full load the elevator moves down.) The “ROPE GRIPPER™” should apply and stop the car within 1220 mm (48”). If the car does not move when the machine brake is opened, the brake drum or disc can be turned to start the car.

- Note: this test can also be performed more safely with the doors closed, and the door lock circuit opened to simulate an open door.

ROPE GRIPPER™ TROUBLE SHOOTING GUIDE

**WARNING! KEEP HANDS CLEAR OF ROPE GRIPPER. FORCES CREATED CAN
CRUSH FINGERS.**

ROPE GRIPPER™ DOES NOT LATCH IN OPEN (LOADED) POSITION

Pawl and solenoid adjustment

If the Rope Gripper opens, but then repeatedly clicks or chatters, and fails to lock in the open position, the pawl may be failing to engage its gear teeth. The pawl is driven by the solenoid through the solenoid clevis, which can be adjusted. Adjustment will vary the gap between the armature washer and the frame of the solenoid when the solenoid is not energized. The default size of this gap is 6 mm or ¼”. See Figure 9, p. 15.

1. Remove the electrical box cover.
2. Loosen the jam nut behind the solenoid clevis.
3. Turn the armature washer counterclockwise a quarter turn.
4. Re-tighten the jam nut.
5. Try the gripper again. If the problem is solved, replace the electrical box cover. If the chattering continues and the Rope Gripper still fails to lock in the open position, try these steps a few more times.

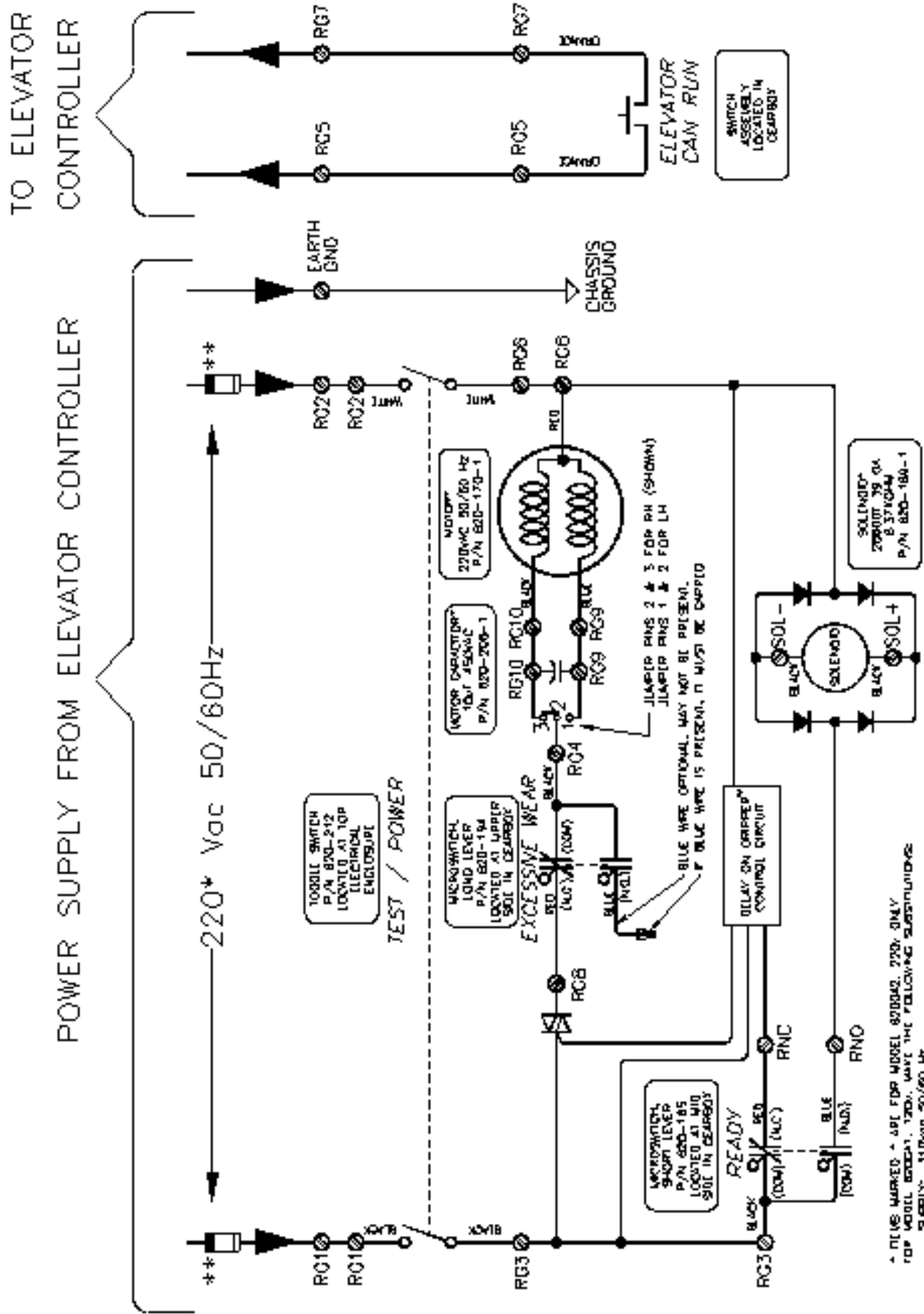

Diagram 4

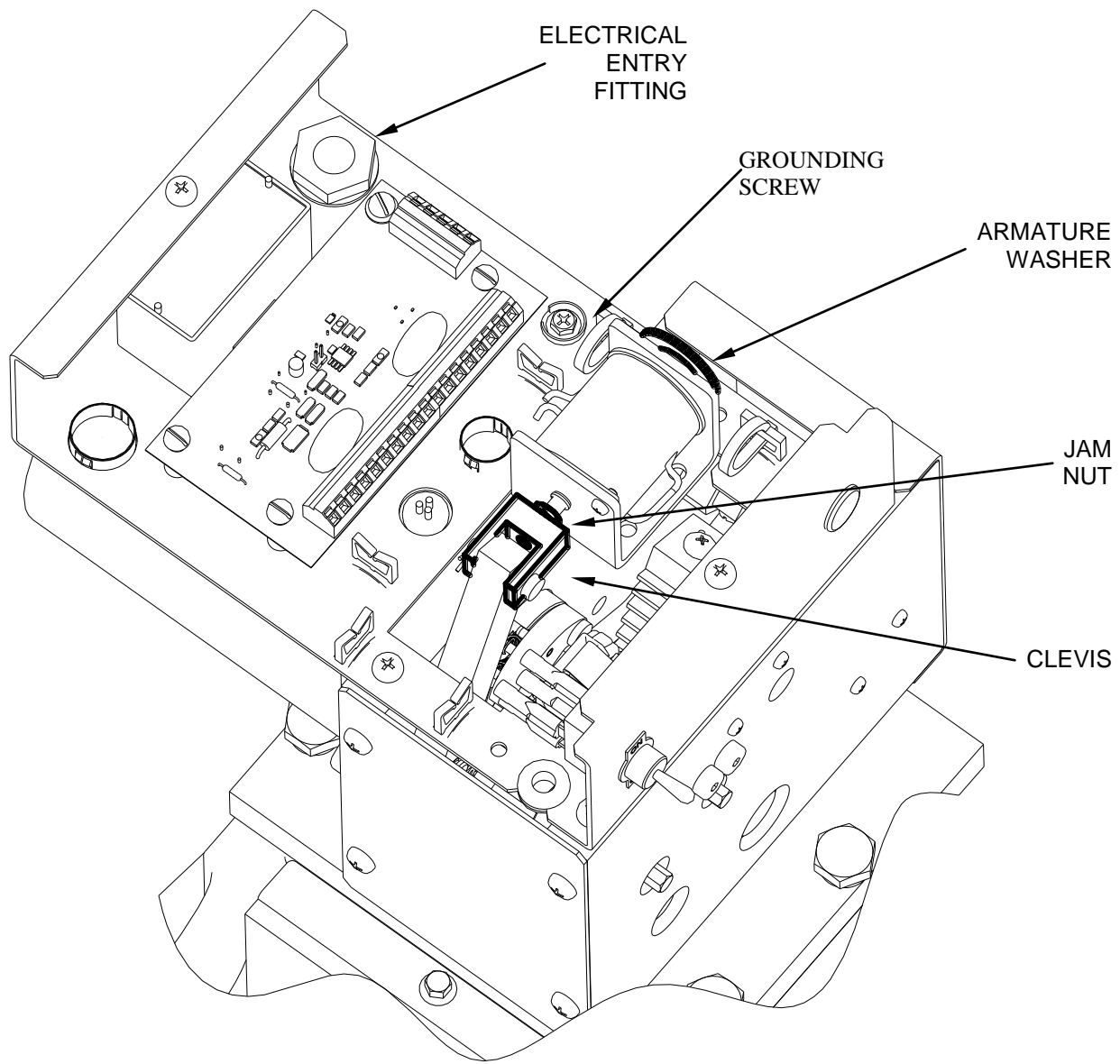

Figure 9

“ROPE GRIPPER™” LUBRICATION

- The Rope Gripper is shipped with a layer of a general purpose grease lubricant applied to the cam surfaces, the four movable shoe guides, and inside the gearbox, to the gears and the latching pawl.
- During maintenance, a thin layer of a general purpose grease lubricant may be applied to these areas if it is found to be lacking.

WIRE ROPE LUBRICATION

- Proper lubrication of the ropes will not affect Rope Gripper operation. Use a high friction lubricant such as Nylube Cable Care # 65 or American Oil Vitalife # 600.

For further technical assistance, please contact HOLLISTER-WHITNEY directly.

Hollister-Whitney Elevator Corp.

#1 Hollister-Whitney Parkway

Quincy, Illinois 62305

Phone: 217-222-0466

Fax: 217-222-0493





www.hollisterwhitney.com

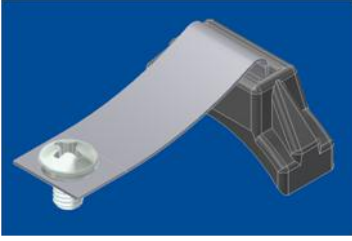

ROPE GRIPPER™ SERVICE PARTS

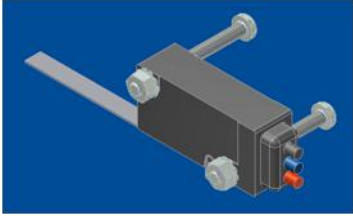
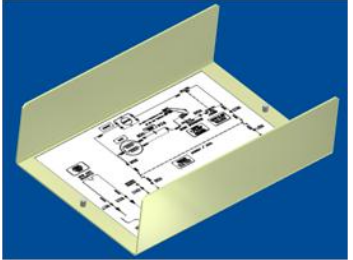
Part Number	QTY	Description	Picture
601-022	2	Lining Assembly	
90-033-M	4	EXTERNAL RETAINING CLIP, 15mm	
601-020-M	1	CONNECTING ARM ASSEMBLY	
620-208-1	1	CAPACITOR FOR 220V 50HZ MOTOR	
620-208-2	1	CAPACITOR FOR 110V 60HZ MOTOR	

Part Number	QTY	Description	Picture
620-251	1	WRENCH HOLDING PIN	
620-268	1	WRENCH ASSEMBLY	
620-300-1	1	LOCKING PAWL/SOLENOID SUB-ASSEMBLY (220V)	
620-300-2	1	LOCKING PAWL/SOLENOID SUB-ASSEMBLY (110V)	
620-301-1	1	MOTOR-CLUTCH SUB-ASSEMBLY (220V)	
620-301-2	1	MOTOR-CLUTCH SUB-ASSEMBLY (110V)	
620-302	1	SWITCH ASSEMBLY	

Part Number	QTY	Description	Picture
620-303	1	CONTACT ASSEMBLY	
620-304	1	DELAY CIRCUIT ASSEMBLY	
620-305	1	FRICTION BRAKE ASSEMBLY	
620-306	1	CONTACT TERMINAL ASSEMBLY	
620-307	1	MICROSWITCH ASSEMBLY, MID LEVER	

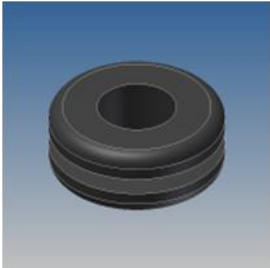
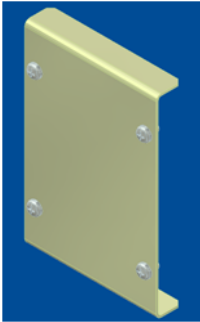
Part Number	QTY	Description	Picture
620-308	1	MICROSWITCH ASSEMBLY, LONG LEVER	
620-309	1	COVER, ELECTRICAL HOUSING W/ LABEL & SCREWS	
620-310-1	1	LOWER FRONT COVER ASSEMBLY, 220V WITH SCREWS	
620-310-2	1	LOWER FRONT COVER ASSEMBLY, 110V WITH SCREWS	
620-207	1	CABLE GLAND, B-TYPE SEAL HOLE & SHORT THREAD	

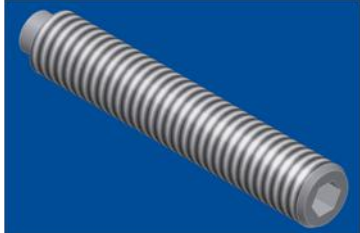
Part Number	QTY	Description	Picture
620-204	2	RUBBER GROMMET	
620-311	1	LOWER COVER ASSEMBLY W/ SCREWS	
620-312	1	LOWER REAR COVER ASSEMBLY W/ SCREWS	
620-121-M	2	HALF DOG SET SCREW, M6 x 35	
620-124-M	2	FLEXIBLE STOP	