

**#92 DISC BRAKE ADJUSTMENTS**  
**#102-091 BRAKE MONITOR**

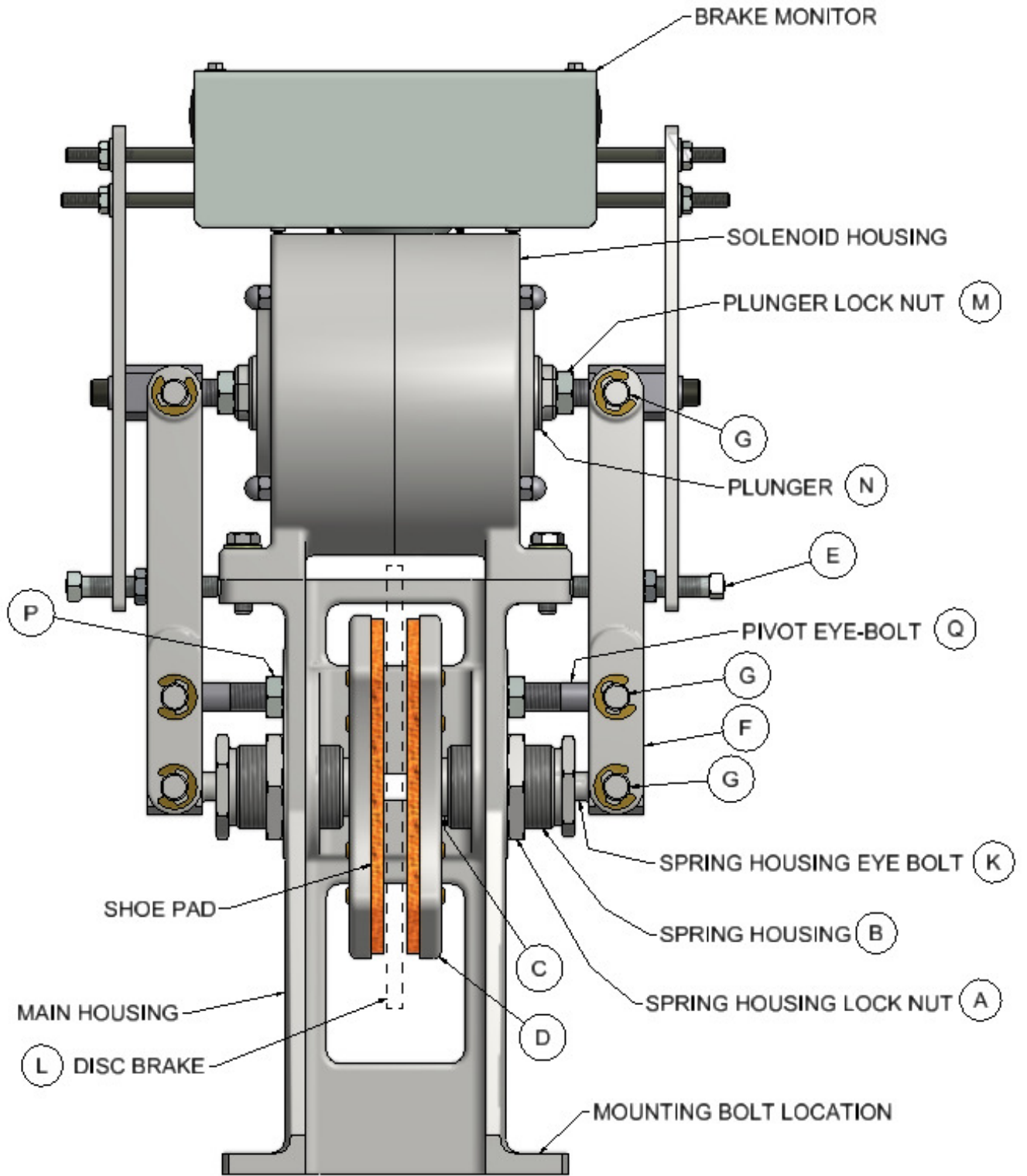

# HOLLISTER-WHITNEY DISC BRAKE WITH BRAKE MONITOR ADJUSTMENT PROCEDURE



HOLLISTER-WHITNEY  
DISC BRAKE WITH MONITOR SWITCH ADJUSTMENTS

**Read and understand ALL of the following Brake Instructions before starting the adjustment procedure!!**

The installation crew, mechanic, adjuster, and maintenance personnel should be thoroughly familiar with the proper installation, adjustment, operation, and maintenance of the HOLLISTER-WHITNEY Disc Brake.

**SAFE ELEVATOR OPERATION DEPENDS ON PROPER BRAKE OPERATION DURING INSTALLATION, AS WELL AS THROUGHOUT THE LIFE OF THE ELEVATOR.**

The Brake MUST be adjusted to meet all local, city, state and national codes.

The A17 and B44 Codes require the Brake to stop and hold a downward moving car loaded at 125% of capacity. It follows that when properly counterbalanced, the Brake will also stop an empty car moving upward.

Initial Brake Tension (Spring Pressure) is factory set. During installation, run elevator to assure proper Brake operation, arm alignment, and shoe clearance. Brake tension will eventually be set to stop and hold 125% load on a downward traveling car. This same tension should also stop a fully loaded downward moving car in approximately the same distance as the slow-down. This setting will help prevent the car sliding into the overhead or the pit during an emergency stop.

For Safety when setting the Brake, be sure the car is out of service. When adjusting for final brake tension, adjust spring pressure with loaded car at the bottom floor. When checking the stopping power of the Brake, keep car near bottom floor.

Object of brake adjustments:

- 1.) Spring pressure strong enough to stop car under all loading conditions.
- 2.) Spring pressure equal so both shoes pick up and drop at the same time.
- 3.) Brake arms parallel and straight up.
- 4.) Shoes parallel to disc with proper and equal air gap on both sides, before and after setting of centering screws.
- 5.) Proper setting of centering screws for quiet operation with minimal air gap in plungers.
- 6.) Proper coil voltage to always energize the Brake, even when the coil heats up. Coil may lose 30% of power when hot.
- 7.) Proper adjustment of monitor switch to indicate proper Brake Operation.

NOTE: ALL INITIAL ADJUSTMENTS SHOULD BE DONE WITH EMPTY CAR IN OVERHEAD AND THE COUNTERWEIGHT LANDED

ADJUSTMENTS:

1.) SPRING ADJUSTMENT:

With Brake applied (Coil de-energized), adjust spring pressure by loosening Lock Nut (A) and screwing Spring Housing (B) into Brake Housing. Note clearance (C), between Brake Shoe (D) and Spring Housing must be equal on both sides and enough for Brake Shoe to pick up when coil is energized. Initially, adjust clearance (C) to 1/8" and tighten Lock Nut (A).

*(Note: This may not be the final setting for 125% load. When finally set at 125% load, the spring pressure may be less than above. Check to see that Brake stops 100% load at approximately the slow-down rate.)*

2.) CENTERING SCREW INITIAL ADJUSTMENT:

With Brake applied, adjust Centering Screws (E) until they are 1/4" away from the Brake Housing.

3.) BRAKE ARM ADJUSTMENT:

With Brake applied, check that Brake Arms (F) are vertically parallel or angled slightly in toward the Solenoid Housing. If adjustment is necessary, remove Snap Rings and Pins (G) [3 per side]. Arms (F) can now be lifted out of the way. Adjust Pivot Eye-bolt (Q) for proper alignment. When aligned, grease Pins, re-assemble Pins, and re-tighten Lock Nut (P).

4.) BRAKE COIL VOLTAGE ADJUSTMENT:

To set the Brake Coil voltage, momentarily energize the Brake. Set the Brake Coil voltage per the following:

	<u>230V Coil</u>	<u>115V Coil</u>
If voltage is constant:	230V	115V
If dual voltage:	250V Pick Up 150V Hold	125V Pick Up 75V Hold

PICK UP voltage should be applied long enough to ensure Solenoid Plungers are touching before dropping to the HOLD voltage. On controls that require a voltage calibration, be sure to adjust calibration.

***Please note: Coil may lose 30% of power when hot!***

5.) BRAKE SHOE GAP ADJUSTMENT:

With Brake energized, set gap between the Shoes (D) and the Disc (L) of 0.012". With Brake applied (Coil de-energized), loosen Lock Nut (M) and adjust Solenoid Plungers (N) so that an equal amount of each Plunger shows on each side of the Solenoid Housing. Energize Brake, check the 0.012" gap, re-adjust as necessary.

NOTES:

- a.) Moving the Plungers out produces a larger gap between the Shoes and Disc when the Brake Coil is energized.
  - b.) If a Shoe is not parallel to the Disc when the Coil is energized, it may be necessary to tap Pivot Bolt (Q) up or down to affect the parallel gap.
  - c.) If one shoe picks up slower than the other, loosen the spring on that side while tightening the spring on the other side an equal amount.
  - d.) When installing a NEW Brake on an EXISTING MACHINE, it may be necessary to shim the Brake Housing to achieve Shoe-to-Disc parallelism if Shoes are parallel with each other but not with the Disc.
- 6.) CENTERING SCREW FINAL ADJUSTMENT:  
With Coil energized, adjust each Centering Screw (E) to just touch Brake Housing, then adjust each Centering Screw “out” one quarter turn, and tighten Lock Nut.
- 7.) SEE BRAKE MONITOR SWITCH ADJUSTMENTS.
- 8.) Run elevator as much as possible to assure proper operation.
- 9.) *CAUTION:* Before releasing car to the public, re-check that Brake is operating properly and will stop 125% load. If Brake Tension is ever changed, re-adjust Items 5.), 6.), and 7.) above.

## BRAKE MONITOR SCHEMATIC AND WORKING PROCEDURE:

**WARNING:** IN ORDER TO DETECT A BRAKE FAILURE, THIS BRAKE MONITOR SWITCH MUST BE PROPERLY ADJUSTED & FULLY OPERATIONAL PRIOR TO BEING PLACED INTO SERVICE.

**IMPORTANT: READ ENTIRE INSTRUCTIONS BEFORE ATTEMPTING ADJUSTMENT!!!**

**▲WARNING**

**SHOCK WARNING: ACTIVE ELECTRIC CIRCUITS!!**

 HOLLISTER-WHITNEY ELEVATOR CORP.

BRAKE MONITOR STANDARD WIRING SCHEMATIC

LABEL-0132N

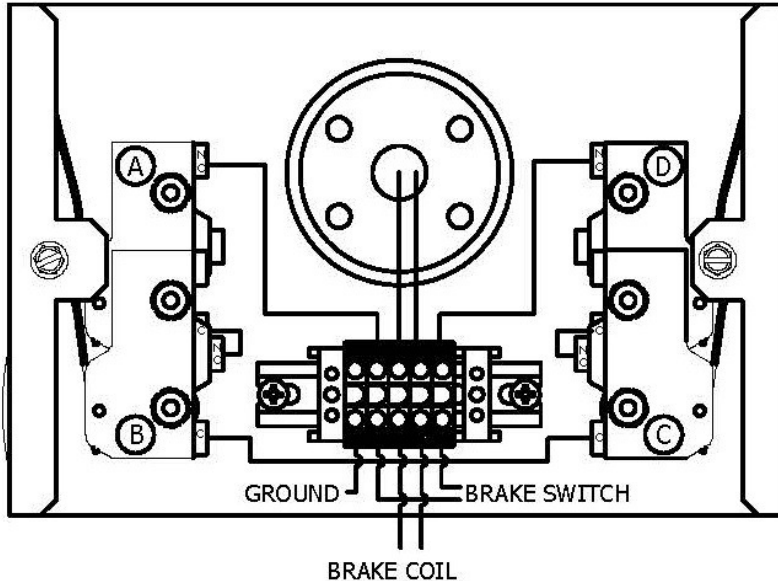

### **BRAKE MONITOR ASSEMBLY 102-091**

NORMAL BRAKE DE-ENERGIZED  
ALL CONTACTS ARE MADE  
CIRCUIT CLOSED BETWEEN BM1 & BM2

NORMAL BRAKE ENERGIZED  
CONTACTS A & D OPEN  
OPEN CIRCUIT BETWEEN BM1 & BM2

BRAKE FAILS TO APPLY PROPERLY (FAILS  
TO DROP)  
CONTACTS A OR D OR BOTH FAIL TO CLOSE

EXCESSIVE BRAKE PAD WEAR OR EXCESSIVE  
THRUST BEARING END PLAY  
CONTACTS B OR C OR BOTH OPEN

BRAKE FAILS TO LIFT  
CONTACTS A OR D OR BOTH FAIL TO OPEN

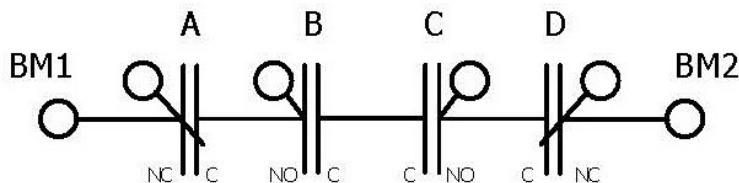

### BRAKE MONITOR ADJUSTMENT:

1. Adjust top bolt "in" until you hear micro switch "click".
2. Rotate top bolt "in" 1 full revolution then tighten jamb nut against extension arm.
3. Adjust bottom bolt "in" until you hear micro switch "click".
4. Rotate bottom bolt "out" until you hear micro switch "click"
5. Rotate bottom bolt "out" 1 full revolution then tighten jamb nut against extension arm.
6. Repeat steps 1 thru 5 on opposite side of monitor.
7. Cycle Brake – check for micro switch activation and circuits are performing as designed.
8. Run machine and check adjustment when machine is at operating temperature.
9. Fine tuning may be needed per bolt until proper adjustment is obtained.

## BOLT ADJUSTMENT DIRECTIONS

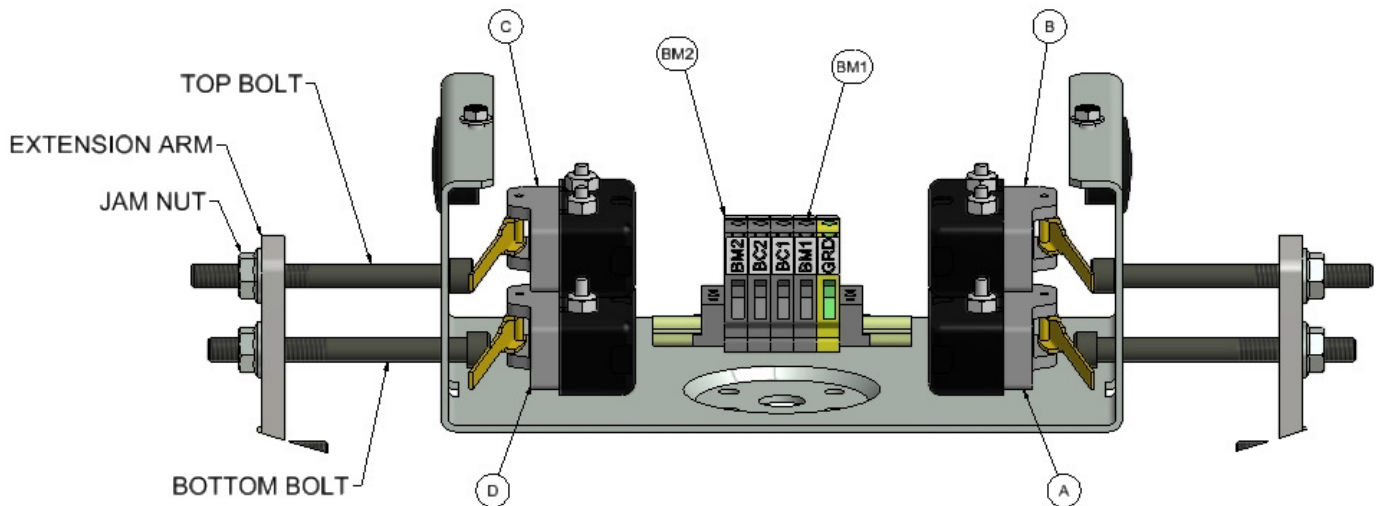

### **BRAKE FAILURE:** DO NOT RE-ADJUST THE BRAKE MONITOR SWITCH UNTIL THE BRAKE PROBLEM HAS BEEN CORRECTED AND THE BRAKE RE-ADJUSTED.

- a.) If both contacts A & D fail to open with Brake energized, failure indicates improper pick up which can cause lining wear. Re-check Brake voltages, air gaps, alignment and freedom of arm and plunger movement, etc. To test this failure, place a jumper across terminals BM1 & BM2. The controls should remove the elevator from service in some fashion (See Suggested Operation on Page #8).
- b.) If contact A or D stays opened when Brake drops, failure indicates improper drop out caused by a bind (find bind and correct) or by excessive worm shaft movement (check thrust bearings etc.). To test, hold open contacts A or D, when elevator stops it should not be able to start (See Suggested Operation on Page #8).
- c.) If contacts B or C open when Brake drops, this indicates either worm shaft movement (check thrust bearings, etc.) or brake lining wear. If cause is normal lining wear, re-adjust Brake including spring tension, air gap, and centering screws, then re-adjust Brake Monitor Switch. To test open contacts B or C. Elevator should not be able to start (See Suggested Operation on Page #8).

NOTE: BRAKES MUST BE INSPECTED DURING NORMAL ELEVATOR MAINTENANCE. IF LININGS INDICATE WEAR, THEN SPRINGS, GAPS AND MONITOR SWITCH MUST BE RE-ADJUSTED ACCORDINGLY.

FOR EXAMPLE: IF LININGS WEAR 1/32", TURNING THE SPRING HOUSING EYEBOLT OUT ONE-HALF (1/2) TURN AND TIGHTENING THE SPRING HOUSING IN ONE-THIRD (1/3) TURN WILL COMPENSATE. PLUNGERS AND THE BRAKE MONITOR WILL NEED TO BE SLIGHTLY RE-ADJUSTED.

ANY ADJUSTMENT MADE TO THE BRAKE MIGHT AFFECT BRAKE MONITOR ADJUSTMENT.

## SUGGESTED OPERATION OF ELEVATOR CONTROLS USED WITH THE HOLLISTER-WHITNEY MACHINE BRAKE MONITOR 102-091

NOTE: These are only suggested modes of operation. HOLLISTER-WHITNEY recognizes that each controls manufacturer may have their own circuits and problems designed to deal with potential Brake failures. It is important that Brake failures be dealt with in some fashion.

### NORMAL OPERATION

- 1.) With the Machine brake de-energized, contacts A thru D are made. Continuity is read from terminals BM1 and BM2.

ACTION: Control circuits and program allow elevator to run.

- 2.) When the elevator runs, the Machine Brake energizes and contacts A & D open. An open circuit is read from terminals BM1 and BM2.

ACTION: Control circuits and programs allow the elevator to continue normal operation.

### ABNORMAL OPERATION

- 1.) After energizing the Brake, check for continuity between BM1 and BM2. If continuity is still read from terminals BM1 to BM2 (all of the contacts A thru D are made), this indicates that the Machine Brake has failed to pick up.

ACTION: Allow the car to run to the next floor. Control circuits and programs should remove the car from service. Apply the "ROPE GRIPPER".

- 2.) After de-energizing the Brake, check for continuity between BM1 and BM2. If continuity is not read from BM1 to BM2 it indicates improper drop-out of the Machine Brake, Brake Lining wear, or excessive Worm Shaft movement.

ACTION: Apply the "ROPE GRIPPER". If a "ROPE GRIPPER" is not available, prevent the car from running. If re-leveling occurs - see below.

- 3.) A constant re-leveling may indicate a Brake failure.

ACTION: Apply "ROPE GRIPPER". If a "ROPE GRIPPER" is not available, allow re-leveling at the floor, run the car to the uppermost floor, open the door during re-leveling, close the doors, and remove the car from service.



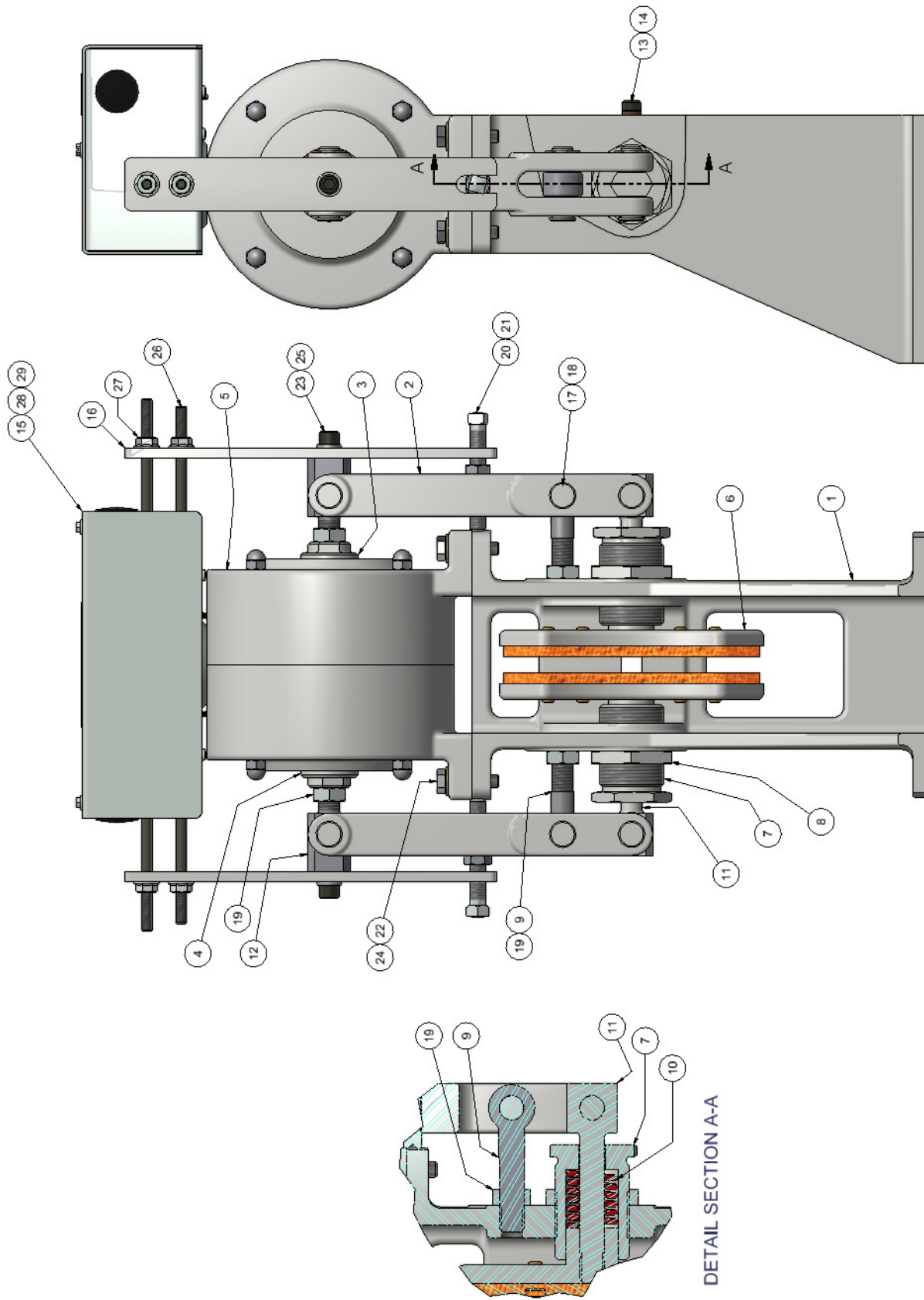

PARTS LIST - DISC BRAKE			
NO.	DESCRIPTION	QTY.	92 BRAKE (10" DISC)
			PART NUMBER
1	DISC BRAKE HOUSING	1	92-001
2	DISC BRAKE LEVER	2	92-003
3	PLUNGER - DISC BRAKE	1	92-006
4	PLUNGER w/RING - DISC BRAKE	1	92-007
5	SOLENOID HOUSING ASSEMBLY - 230V COIL	1	92-028
	SOLENOID HOUSING ASSEMBLY - 115V COIL		92-028-1
6	DISC BRAKE SHOE ASSEMBLY	2	92-029
7	SPRING HOUSING	2	92-049
8	NUT - SPRING HOUSING	2	92-050
9	PIVOT EYEBOLT	2	92-051
10	SPRING	2	92-053
11	EYEBOLT - SPRING HOUSING	2	92-059
12	EYEBOLT - SLOTTED PLUNGER	2	92-064
13	SHOULDER BOLT	2	102-066
14	BUSHING	2	92-067
15	BRAKE MONITOR ASSEMBLY	1	102-091
16	BRAKE ARM EXTENSION	2	92-093
17	PIN - PIVOT ARM	6	377-004
18	E-RING, 5133-50	6	201-041
19	NUT - HEX JAM	4	1/2- 13 UNC
20	SQUARE HEAD SET SCREW	2	3/8 -16 UNC X 2.5
21	HEX JAM NUT	2	3/8 - 16 UNC
22	HEX HEAD CAP SCREW	4	5/16 UNC x 1.25
23	SOCKET HEAD CAP SCREW	2	5/16 - 18 UNC x 0.625
24	STANDARD WASHER	4	5/16" WASHER
25	STANDARD LOCK WASHER	2	5/16 WASHER
26	SOCKET HEAD CAP SCREW	4	1/4-20 UNC X 2.75
27	WHIZ NUT	4	1/4 - 20 UNC
28	SOCKET HEAD CAP SCREW	2	#10-24 UNC x 0.5
29	STANDARD LOCK WASHER	2	#10 LOCK WASHER

Coils for #92 Disc Brake

- 1) Coil (Part # 92-022) 1.66 A, 138 OHM - Constant 230 VDC,  
or Step Down 250 V Pick, 150 V Hold
- 2) Coil (Part # 92-035) 3.48 A, 33 OHM - Constant 115 VDC,  
or Step Down 125 V Pick, 75 V Hold

