



Hollister-Whitney Elevator Co., LLC

2603 North 24th Street
Quincy, IL 62305
Phone: 217-222-0466

Fax: 217-222-0493
e-mail: info@hollisterwhitney.com
www.hollisterwhitney.com

INSTALLATION, MAINTENANCE, AND TROUBLE SHOOTING INSTRUCTIONS

FOR

**Models #620, #622, #624, #625, #626, & #626SPL
Hollister-Whitney “Rope Gripper”[®] & Pumping Unit
(Patent # 5,228,540)
CSA Certification File #88181**





Hollister-Whitney Elevator Co., LLC

2603 North 24th Street
Quincy, IL 62305
Phone: 217-222-0466

Fax: 217-222-0493
e-mail: info@hollisterwhitney.com
www.hollisterwhitney.com

Table of Contents

“ROPE GRIPPER®” RATINGS CHART	3
“ROPE GRIPPER®” MOUNTING CHANNEL GUIDELINES.....	4
INSTALLATION OF “ROPE GRIPPER®”	7
TESTING OF “ROPE GRIPPER®”	8
“ROPE GRIPPER®” LINING WEAR-IN	9
LINING WEAR & REPLACEMENT	11
TESTING ALL CIRCUITS.....	12
SUGGESTED CONTROLLER CIRCUITS.....	12
GRC1 DESCRIPTION.....	12
GRC2 DESCRIPTION.....	13
DZC1 DESCRIPTION.....	14
DZC2 DESCRIPTION.....	14
HOLLISTER-WHITNEY “ROPE GRIPPER®” OPERATION.....	14
NORMAL OPERATION.....	14
OVERSPEED.....	14
OVERSPEED RESET.....	14
UNINTENDED MOTION.....	14
UNINTENDED MOTION RESET.....	14
MANUAL OPENING.....	15
TEST PROCEDURE FOR COMPLIANCE WITH ELEVATOR SAFETY CODES.....	15
1) POWER INTERRUPTION TEST.....	15
2) ASCENDING CAR OVERSPEED TEST.....	15
3) UCM - UNCONTROLLED CAR MOTION TESTS.....	15
SUGGESTED ADDITIONAL SOFTWARE FOR ADDED SAFETY.....	16
ROPE GRIPPER® TROUBLE SHOOTING GUIDE	16
GRIPPER SET ON ROPES – GRIPPER WILL NOT RESET	16
PUMP UNIT CYCLING ON AND OFF.....	16
MICROSWITCH ADJUSTMENT PROCEDURE	18
BLOWING CONTROLLER FUSES.....	19
CHECKING PUMP UNIT AMP DRAW.....	20
AIR IN LINE (CHANGING OUT HOSES OR CYLINDERS).....	20
HYDRAULIC CYLINDER REPLACEMENT INSTRUCTIONS	20
FLUID LEVEL LOW	21
HAND PUMP DOES NOT FUNCTION	21
“ROPE GRIPPER®” LUBRICATION	21
WIRE ROPE LUBRICATION	21
CSA Certification of Compliance.....	22
EC Type – Examination Certificate.....	23
Dimensional Sheets and Parts Lists	24

“ROPE GRIPPER®” RATINGS CHART

		ROPE GRIPPER MODEL							
		618	620	622	624	625	626	626 SPL	
	MAX. OUT TO	inch	3.375	4.875	6	10	11.5	10	13.75
	OUT OF	mm	86	124	152	254	292	254	349
	POWER SUPPLY	6A, 120 VAC, 1 PH, 60Hz							
	CONTACT RATINGS	6A, 250 VAC, 0.15A, 250VDC							
1:1 ROPING	MAXIMUM RATINGS	RATED SPEED	fpm	250	350	600	1200		
			m/s	1.27	1.78	3.05	6.10		
			m/m	76	107	183	366		
		ROPE GRIPPER TRIPPING SPEED	fpm	303	402	690	1368		
			m/s	1.54	2.04	3.51	6.95		
			m/m	92	123	210	417		
	CAR RATED LOAD	lbs	1800	2500	5000			10000	
		kg	816	1134	2268			4536	
	TOTAL SYSTEM LOAD	lbs	11000	11500	18600			38000	
		kg	4990	5216	8437			17237	
MINIMUM RATINGS	CAR RATED LOAD	lbs	600		1500		2500		
		kg	272		680		1134		
	CAR & CWT MASS	lbs	2280		6000		8000		
		kg	1034		2722		3629		
2:1 ROPING	MAXIMUM RATINGS	RATED SPEED	fpm	175	250	400	800		
			m/s	0.89	1.27	2.03	4.06		
			m/m	53	76	122	244		
		ROPE GRIPPER TRIPPING SPEED	fpm	225	303	459	921		
			m/s	1.14	1.54	2.33	4.68		
			m/m	69	92	140	281		
	CAR RATED LOAD	lbs	3600	5000	10000			20000	
		kg	1633	2268	4536			9072	
	TOTAL SYSTEM LOAD	lbs	22000	23000	38000			76000	
		kg	9979	10433	17237			34473	
MINIMUM RATINGS	CAR RATED LOAD	lbs	1200	1500	2500		5000		
		kg	544	680	1134		2268		
	CAR & CWT MASS	lbs	4560	6000	8000		16000		
		kg	2068	2722	3629		7257		
4:1 ROPING	MAXIMUM RATINGS	RATED SPEED	fpm	63	87	150	300		
			m/s	0.32	0.44	0.76	1.52		
			m/m	19	27	46	91		
		ROPE GRIPPER TRIPPING SPEED	fpm	79	110	189	355		
			m/s	0.40	0.56	0.96	1.80		
			m/m	24	33	58	108		
	CAR RATED LOAD	lbs	7200	10000	20000			40000	
		kg	3266	4536	9072			18144	
	TOTAL SYSTEM LOAD	lbs	44000	46000	76000			152000	
		kg	19958	20865	34473			68946	
MINIMUM RATINGS	CAR RATED LOAD	lbs	2400	3000	5000		10000		
		kg	1089	1361	2268		4536		
	CAR & CWT MASS	lbs	9120	12000	16000		32000		
		kg	4137	5443	7257		14515		

HOLLISTER-WHITNEY “ROPE GRIPPER”[®]

*** With 620-100 Pumping Unit ***

Instructions for Model #620, 622, 624, 625, 626 & 626SPL (Patent #5,228,540)

WARNING: KEEP HANDS CLEAR OF “ROPE GRIPPER”[®].

FORCES CREATED CAN CRUSH FINGERS.

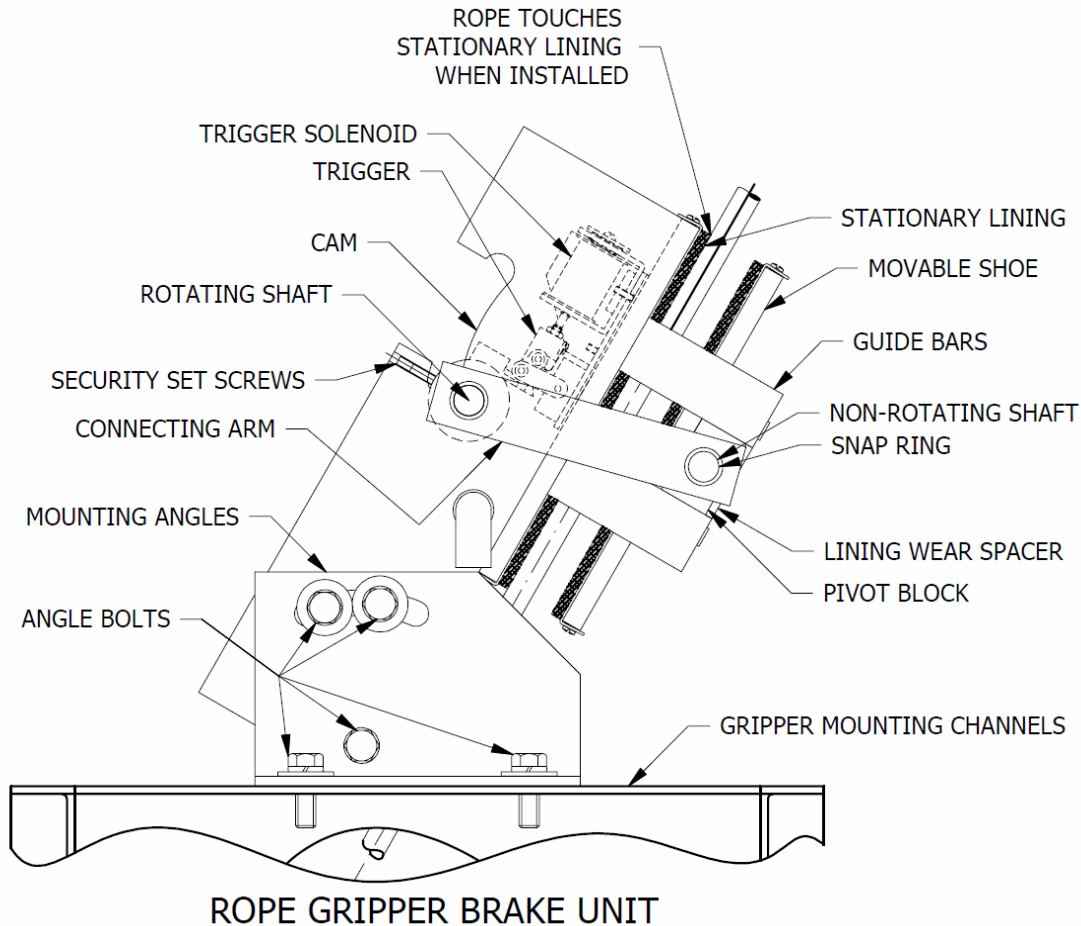

FIGURE 1

“ROPE GRIPPER”[®] MOUNTING CHANNEL GUIDELINES

- The Mounting Channel Framework supporting the gripper must withstand upward and downward forces according to **Chart 1** below and applicable codes.
- The Mounting Channel Framework must be sufficiently sized to securely hold the “ROPE GRIPPER”[®] and elevator while preventing any sliding. The Traction Machine must also be prevented from sliding. See **Figures 2 and 3** for suggested machine room mountings. Additionally, see **Figures 9 thru 12** for Hollister-Whitney machines with built-in factory “Rope Gripper”[®] mounts.
- When adding a “ROPE GRIPPER”[®] to an existing installation, it may not be possible to mount the gripper in the machine room. It is acceptable to mount the gripper horizontally or upside down on the car or counterweight side, so long as proper consideration for access is given for future gripper maintenance and Pumping Unit location. Note: The Pumping Unit must be mounted right side up. The hydraulic hose standard length is 27 inches. Various hose lengths of up to 8 feet are available in stock, with longer lengths up to 30 feet available by special order.

Typical Mounting Arrangements for Overhead Machines New Installations

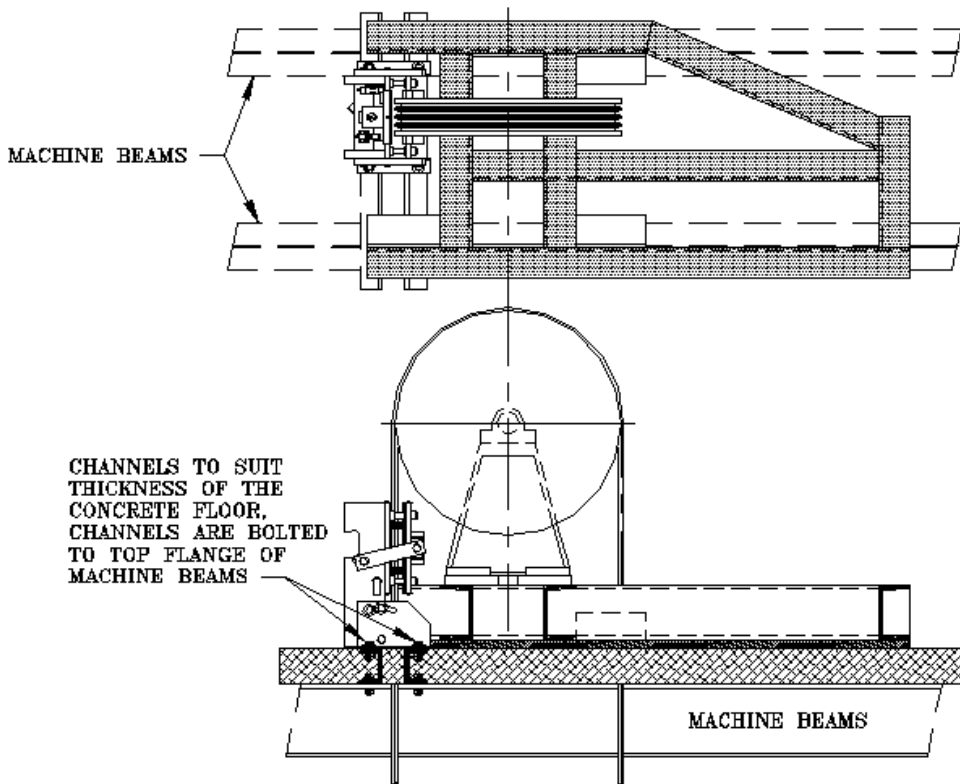
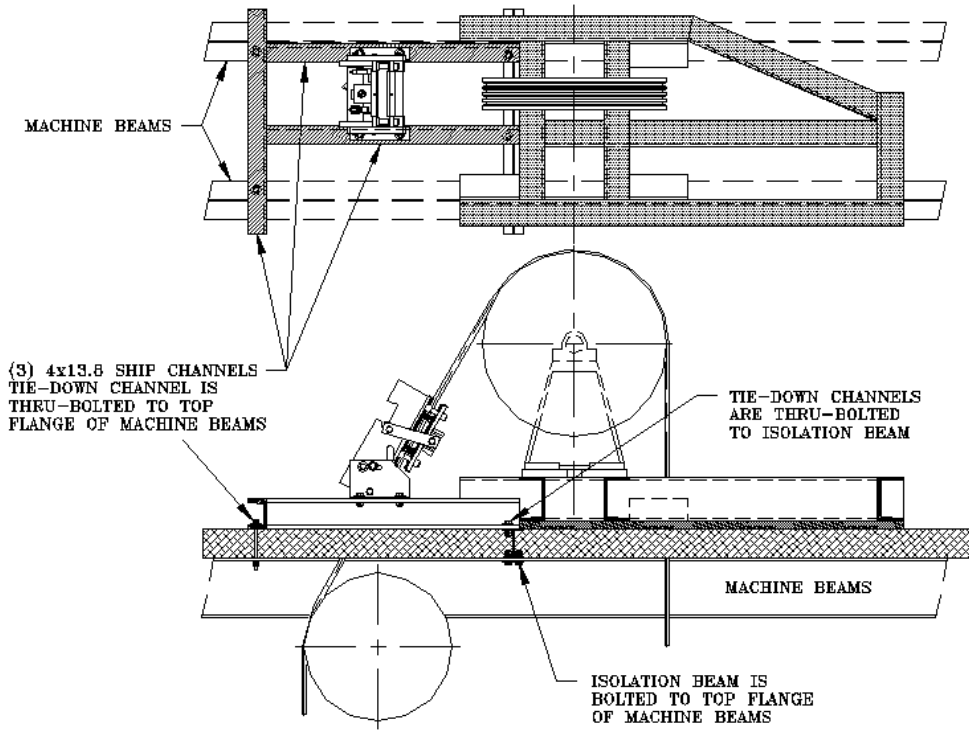

FIGURE 2

Typical Mounting Arrangements for Overhead Machines Existing Installations

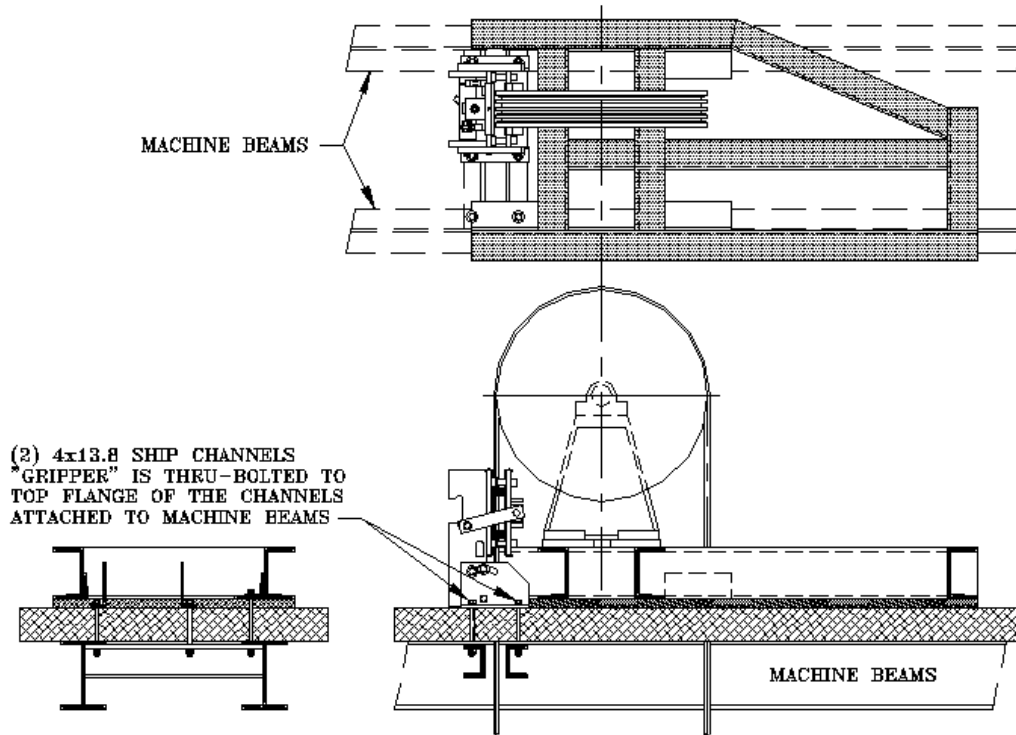
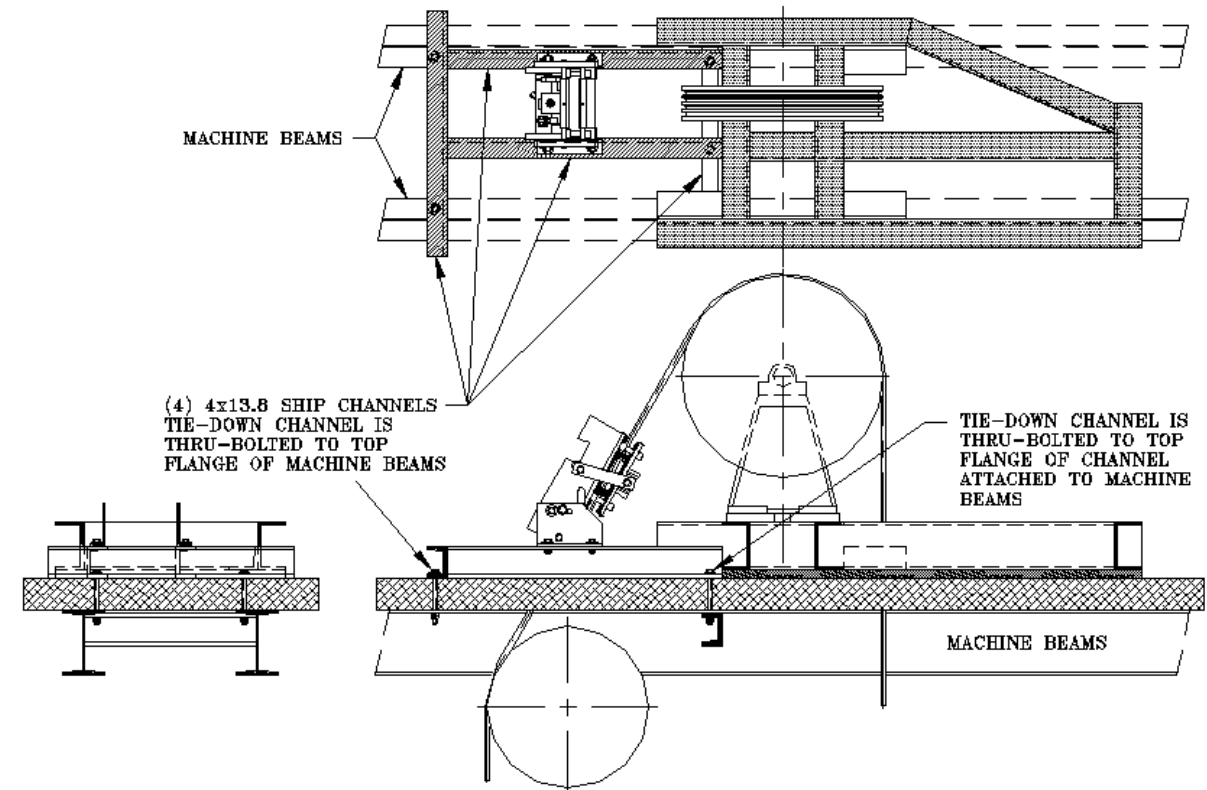

FIGURE 3

INSTALLATION OF “ROPE GRIPPER®”

- Remove shipping cap from oil reservoir and install oil cap.
- Be sure security set screws are holding the rotating shaft in the LOADED position as shown in **Figure 1** above.
- Remove both connecting arms after removing the four retaining rings.
- Remove movable shoe assembly.
- Attach “ROPE GRIPPER®” to mounting channels with appropriate bolts per **Chart 1** below. Do not fully tighten bolts yet.

MODEL #	APPROXIMATE UP & DOWN FORCE	GRADE 5 MOUNTING BOLTS* (Approximate Torques)	REFERENCE DRAWINGS
620	2000 lbs	1/2" UNC @ 74 ft-lbs	Pg 24-25
622	4000 lbs	1/2" UNC @ 74 ft-lbs	Pg 26-27
624	4000 lbs	5/8" UNC @ 143 ft-lbs	Pg 28-29
625	4000 lbs	5/8" UNC @ 143 ft-lbs	Pg 30-31
626 & 626SPL	8000 lbs	5/8" UNC @ 143 ft-lbs	Pg 32-35

Note: Mounting must conform to applicable codes.

CHART 1

- Position the “ROPE GRIPPER®” so that the stationary shoe lining barely touches the ropes from top to bottom. Make sure the gripper is squarely aligned, and centered side to side as much as possible, with the ropes. Misalignment may cause uneven and/or excessive lining wear.
- Securely fasten the gripper mounting bolts (5 bolts per side). Torque to specifications in **Chart 1** above. Note: The 6 5/8" bolts supplied with the 626 and 626-SPL Grippers ONLY securing the mounting angles (3 per side) to the Gripper are Grade 8 and should be tightened to 225 ft-lbs.
- Double check rope alignment. Make sure the ropes touch the stationary shoe lining evenly.
- Reinstall movable shoe assembly.
- Reinstall connecting arms with chamfered edges facing inside the gripper and secure the four snap rings.
- Mount pumping unit in the best available location. Unit must be upright, but can be placed on either side of the gripper.
- If necessary, wiring on the gripper can be rerouted to opposite side of assembly by removing the 90° box connector and pulling wire through and out the opposite side.
- Remove the knock-out for the hydraulic line and install the supplied Rubber Grommet.
- Route male hydraulic fitting through knockout hole on side of pumping unit. Inside pumping unit, push male Quick-Connect fitting into female fitting while lifting ring on female fitting. Release ring to secure the fittings together.
- Wiring from the gripper to pump unit is color coded per **Chart 2**.
- Connect terminals RG1, RG2, RG5 and RG7 to elevator control. Check control diagram for proper connection.
- When wiring and hydraulic connections are complete, make sure valve stem (dump valve) in pumping unit is set to AUTOMATIC. Turn pumping unit test switch ON (see **Figure 4**). The gripper Latch solenoid should energize and push the trigger onto the latch. If it fails to do so, check control wiring.

White	RG2
Black	RG3
Red	RG4
Orange	RG5
Blue	RG6
Green	Ground

Pigtail to Pumping Unit Wiring

Chart 2

BULLETIN 1144

Page 7 of 40

10/04/18

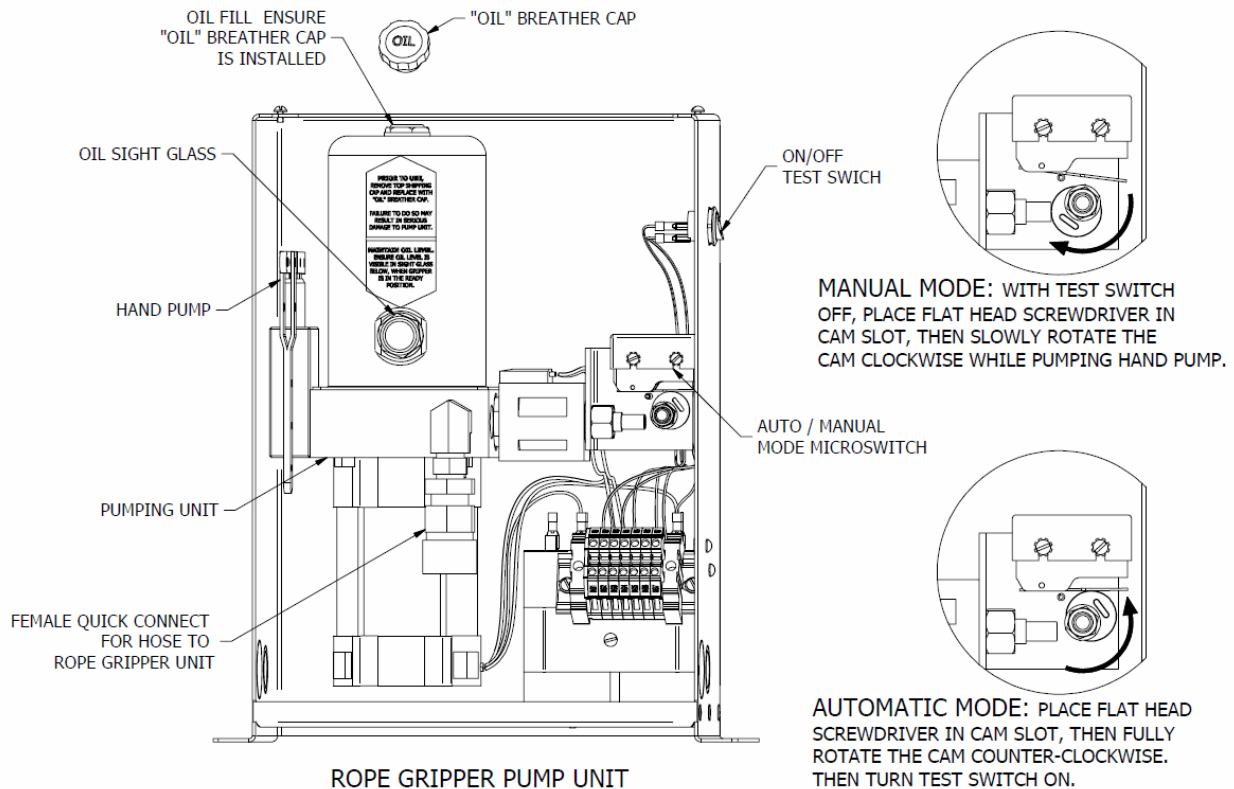

FIGURE 4

- When the solenoid is energized, loosen the two security set screws a turn or two. If rotating shaft moves, turn valve stem to MANUAL and use hand pump to move shaft back, or jump terminal RG3 to RG4 to temporarily operate electric pump. Make sure the trigger has properly engaged the latch.
- Remove security set screws. *Once removed, store set screws in bottom of pump unit.*
NOTE: Security set screws must be completely removed when "ROPE GRIPPER®" activates to prevent gripper failing to set or damage to the unit.
- Unit is now ready for required testing and lining wear-in.

TESTING OF "ROPE GRIPPER®"

- Make sure controller safety circuit is active and clear for running, and the pumping unit valve stem is in AUTOMATIC. Turn test switch ON. The "ROPE GRIPPER®" should be in the ready (LOADED) position (NOT gripping the ropes).
- Turn test switch to OFF. This should activate the "ROPE GRIPPER®", gripping the ropes. Be sure that while gripping the ropes, the microswitch contacts on the "ROPE GRIPPER®" stop or prevent power from being applied to the motor and machine brake.
- Turn the valve stem in the pumping unit to MANUAL. This will open the manual microswitch contact and prevent the elevator from running.
- Use hand pump to return the gripper to the ready or loaded position.
- Turn test switch ON. Elevator should still be prevented from running.
- Turn the valve stem back to AUTOMATIC. The manual contact will close allowing the elevator to run.

“ROPE GRIPPER[®]” LINING WEAR-IN

- A line has been marked on the side wall of the gripper to aid in the Wear-In process. Note that at this point in the procedure, this line is well **above** the Connecting Arm and will be met or covered by the Connecting Arm during the Wear-In process (see **Figure 1** for location of Connecting Arm).
- Confirm the moveable shoe has been set up for the proper size ropes (**Chart 3**).
- Make sure pumping unit valve stem is in AUTOMATIC and test switch is ON.
- Run the car at the slow or inspect speed and wipe down the ropes to remove any dirt and/or excess oil and grease from top to bottom. Return car to top floor.

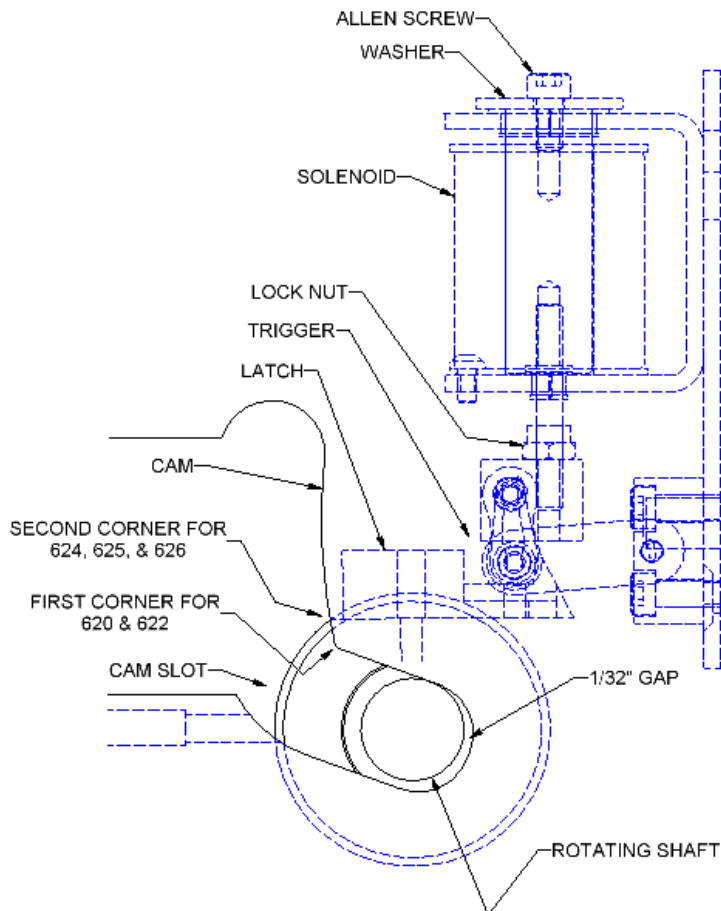

FIGURE 5

- Jump terminals RG5 to RG6 and run the empty car in slow speed in the direction that will pull the ropes thru the “ROPE GRIPPER[®]” (typically DOWN). When the car is up to speed, turn the test switch OFF. The “ROPE GRIPPER[®]” will grip the ropes with a light pressure and ropes will begin to wear grooves in the linings.
- As the linings wear-in, the rotating shaft will move up the cam slot and around the corner(s) of the cam noted above (**Figure 5**), and the connecting arms (see **Figure 1**) will move up the side wall and begin to match or line up with the wear-in line marked on the side wall.

Note: #624, #625, and #626 have **two** corners. These grippers are **not** worn-in until the rotating shaft goes past the **second** corner of the cam as noted above (see **Figure 5**) and the connecting arm meets or covers the line marked on the side wall.

- **Note that it may take several car runs to complete lining wear-in.**
- Once the rotating shaft has turned the corner(s) and the wear-in line is matched or covered,

stop the car and remove the jumper from RG5 to RG6.

- If the lining wear-in is not completed after the grooves in the linings have reached approximately 1/16" deep, spacer shims (**Figure 6**) can be moved from between the shaft support blocks and moveable shoe to the outside of the support block to allow the rotating shaft to completely turn the corner and move up the cam. Refer to **Chart 3** for initial spacer and shim set-up. **Note: Before changing spacers, install security set screws to prevent unintended "ROPE GRIPPER®" activation, which could lead to severe personal injury and/or damage to the unit.**

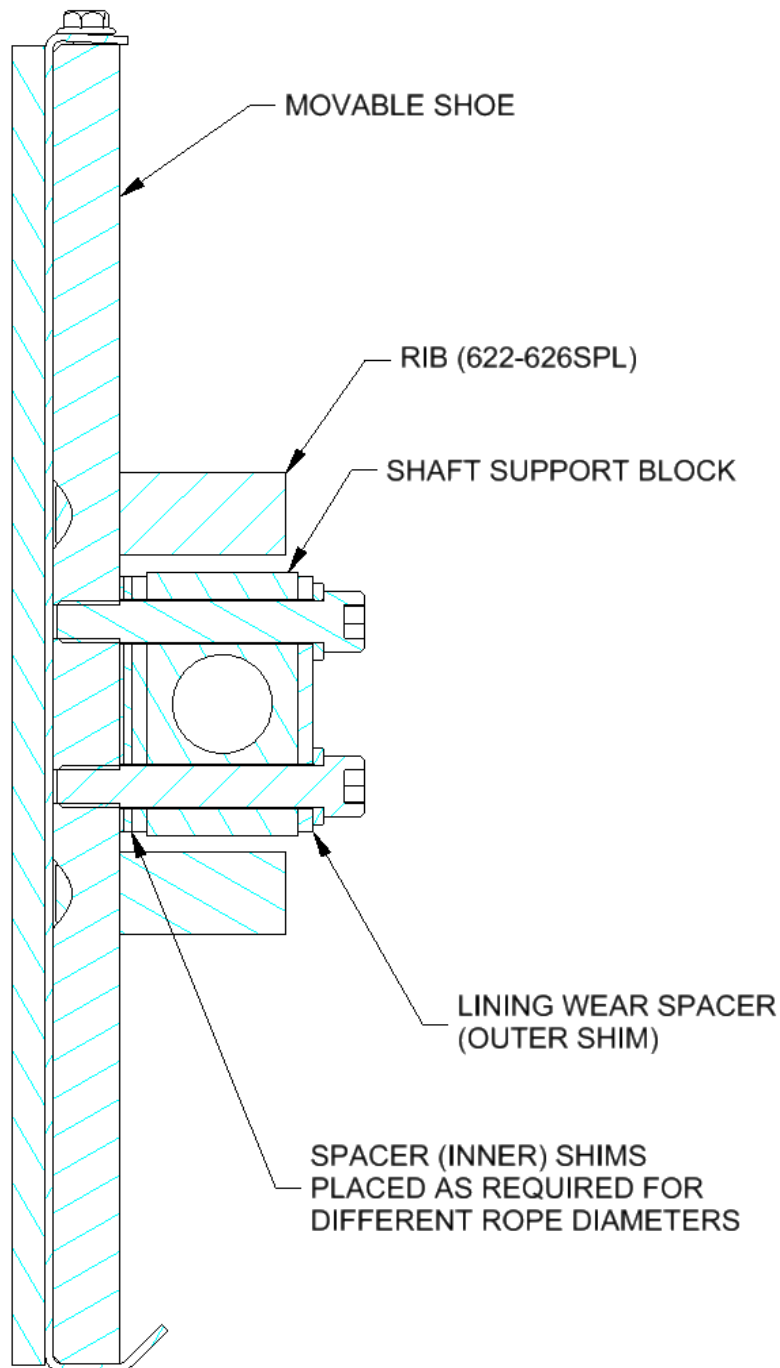

FIGURE 6
BULLETIN 1144
Page 10 of 40
10/04/18

Rope Sizes			620 or 622		624, 625, 626 & 626SPL	
			Outer Shims	Inner Shims	Outer Shims	Inner Shims
Nominal (Inch)	MM Range	Decimal Equivalent	Lining Wear Spacer + Excess Spacers on Back of Block	Spacer Shims between Block and Shoe	Lining Wear Spacer + Excess Spacers on Back of Block	Spacer Shims between Block and Shoe
3/8"	9	0.354	1/8"	1/32 + 2 x 1/16 + 1/8"	1/8"	1/32 + 2 x 1/16 + 1/8"
	10	0.394				
7/16"	11	0.433	1/8"	1/32 + 1/16 + 1/8"	1/8"	1/32 + 1/16 + 1/8"
1/2"	12	0.472	1/16 + 1/8"	1/32 + 1/8"	1/16 + 1/8"	1/32 + 1/8"
	13	0.512				
9/16"	14	0.551	2 x 1/8"	1/32 + 1/16"	2 x 1/8"	1/32 + 1/16"
5/8"	15	0.591	1/16 + 2 x 1/8"	1/32"	1/16 + 2 x 1/8"	1/32"
	16	0.63				
11/16"	17	0.669			1/16 + 2 x 1/8"	1/32 & Flip Block Thin Side to Ropes
	18	0.709				
3/4"	19	0.748			1/32 + 1/16 + 2 x 1/8"	Flip Block Thin Side to Ropes
	20	0.787				

CHART 3

LINING WEAR & REPLACEMENT

- The linings will wear, especially after multiple high-speed stops. When gripping the ropes, the rotating shaft will move towards the upper end of the cam as the linings wear. Near the end of the cam, the excessive wear microswitch will open and the “ROPE GRIPPER®” will not automatically reopen.
- To inspect linings for wear, first reopen the gripper using the manual pump. Once in the open position install the security set screws so they touch the rotating shaft. If the grooves in the linings have worn to approximately 3/16” or greater, new linings should be installed as soon as possible. **Note: Before changing shoes or spacers, install security set screws to prevent unintended “ROPE GRIPPER®” activation,** which could lead to severe personal injury and/or damage to the unit. **NOTE: Always replace linings in pairs.**
 1. If installing new linings, remove both connecting arms by removing 4 snap rings. Remove moveable shoe assembly. Remove screws from each lining assembly and remove linings. Refer to **Chart 3** for initial spacer and shim set-up. **NOTE:** It may be necessary to loosen mounting bolts to tip gripper in order to allow access to stationary shoe. When linings have been replaced, follow the INSTALLATION OF “ROPE GRIPPER®” procedure and the LINING WEAR-IN procedure.
 2. If lining wear is not excessive (less than 3/16”), spacer shims (**Figure 6**) can be added between the shaft support blocks and the moveable shoe. Remove the bolts that hold the blocks to the movable shoe, place the lining wear spacer shims under the blocks and reinstall and tighten bolts. Addition of shims will lower the position of the rotating shaft toward the bottom end of the cam when gripping.
- When inspection/replacement is complete, turn the valve stem to AUTOMATIC and the pumping unit ON. Carefully remove the security set screws. If necessary, use hand pump to prevent rotating shaft from moving when removing the security set screws. The “ROPE GRIPPER®” is now ready for operation. Check to ensure that the rotating shaft will be around the corner(s) at the bottom of the cam (connecting arm position **matches or covers the wear-in line** marked on the side wall) when gripping the ropes.

TESTING ALL CIRCUITS

- During each test the “ROPE GRIPPER[®]” should:
 - A. Grip the Ropes,
 - B. Stop the car and/or prevent the car from running, and
 - C. Open the control safety circuits disconnecting power to the motor and machine brake.
- The following three tests should be made while the car is running in slow speed in both the up and down directions.
 - 1) Turn the pump test switch OFF. Observe A, B, and C above.
 - 2) a) With the car in the door zone and the car doors and the hoistway doors not in the closed position (doors partially opened with the car door switch and the hoistway door interlock opened), disconnect the door zone feed (as if leaving the door zone) and observe A, B, and C above.
 - b) Repeat the same test in 2) a) with the doors fully open.
 - 3) Manually open the governor overspeed switch and observe A, B, and C above. **NOTE:** The controller’s safety circuits should require a manual reset before gripper reopens.

NOTE: The controller’s safety circuits should require a manual reset before the “ROPE GRIPPER[®]” reopens. See **IMPORTANT** notes on page 14 under sections titled **OVERSPEED RESET** and **UNINTENDED MOTION RESET**.

SUGGESTED CONTROLLER CIRCUITS

- Both the B44 and A17.1-2000 Codes require new circuitry for activation of the “ROPE GRIPPER[®]”. It is the controller manufacturer’s responsibility to provide proper circuitry that meets all applicable codes and laws for operating this device.
- The function of the “ROPE GRIPPER[®]” is to grip the ropes and stop the car. We recommend that the gripper is activated when an overspeed occurs or when the car leaves the floor (door zone) with the doors open (hoistway door unlocked and/or the car gate switch open). If the doors happen to open while the car is between floors, the gripper should not be activated.
- In addition, the “ROPE GRIPPER[®]” activates when there is a loss of power. When power returns, if the car is in the door zone, we recommend resetting the gripper. If the car is between floors when power returns, or if changing from “Inspection” to “Automatic” operation, we suggest a time interval to signal door closure, and when the car gate switch or door interlock makes contact, then reset the “ROPE GRIPPER[®]”.
- The suggested circuits shown in **Diagrams 1 & 2** activate the gripper by opening contacts RG1, RG2, DZ1, and DZ2. Relay coils RG1, RG2, DZ1 and DZ2 are controlled by the Governor overspeed switch (GOS) and function blocks GRC1, GRC2, DZC1, and DZC2, respectively.

GRC1 DESCRIPTION

- If the car is not in the door zone when main line power turns “ON”, or when switching from “Inspection” to “Normal Operation”, or when resetting the Governor overspeed switch; allow a time interval, signal the door closure, and when the car gate or door interlock contact makes, energize RG1.
- Anytime the car is in the door zone (“Inspection” or “Normal Operation”), RG1 is de-energized when both the car door contact and hoistway door interlock contact are opened. Should the car now leave the door zone (unintended motion), power to the gripper is removed and the gripper is activated. In the door zone, when the car door contact or hoistway door interlock contact is made, energize RG1. If the car should leave the door zone

with RG1 energized then gripper activation is prevented. RG1 should remain energized even if both the car and hoistway doors are opened while between floors. When the car is in the door zone again, RG1 should function as above.

GRC2 DESCRIPTION

- Redundant circuits are required by the 2000 A17.1 and B44 Codes. Circuits for RG2 function identical to RG1 except separate logic for the timing function, door locks, gate switch and door zone should be used. DZC1 logic could be used for circuits of RG1 and DZC2 for circuits of RG2. (See NOTE in **Diagram 3**)

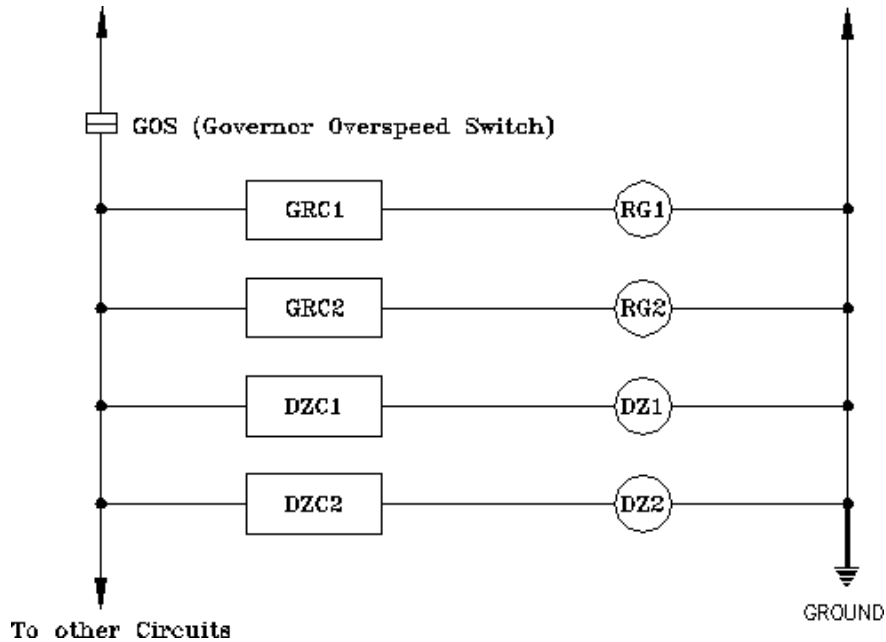

DIAGRAM 1

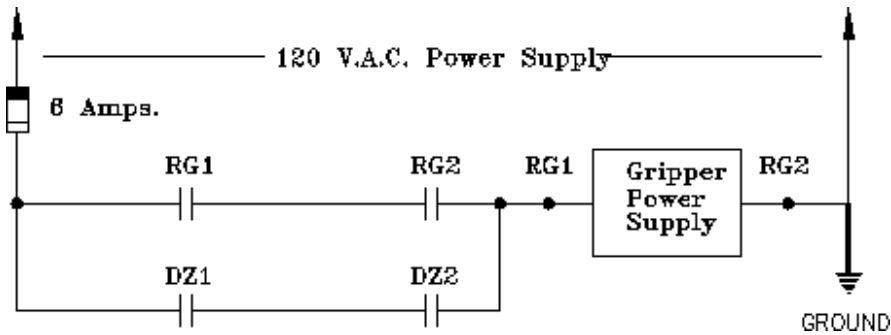
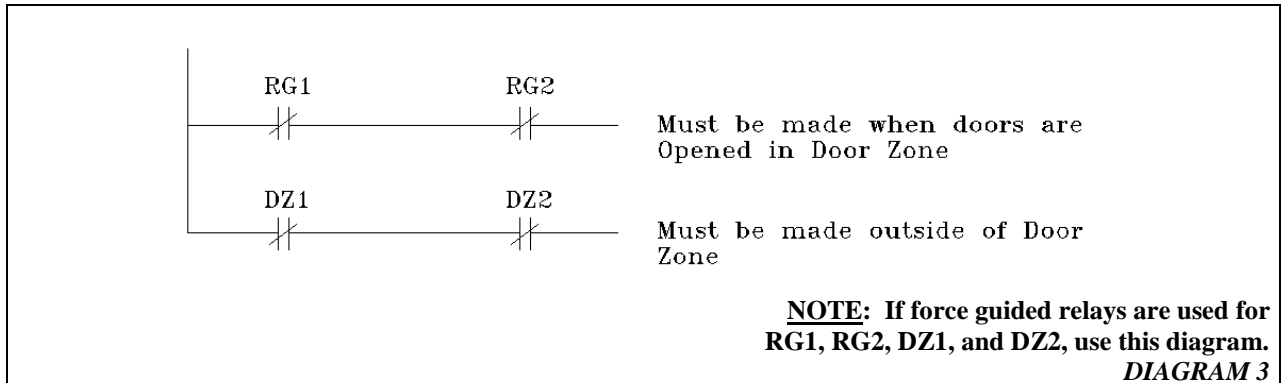

DIAGRAM 2



DZC1 DESCRIPTION

- DZ1 is energized in the door zone and de-energized outside of the door zone (See **Diagram 3** NOTE). Maximum door zone is 10"

DZC2 DESCRIPTION

- Circuits for DZ2 function are identical to DZ1 except a separate door zone signal is utilized.
- If the above circuits (**Diagram 3**) do not make contact when required, the elevator must be prevented from running. If other types of relays are used, circuits must prove that contacts from RG1, RG2, DZ1 and DZ2 are functioning properly and when a failure is detected the elevator must be prevented from running.

HOLLISTER-WHITNEY “ROPE GRIPPER®” OPERATION

NORMAL OPERATION

- Power to the “ROPE GRIPPER®” is constantly maintained. When in the door zone DZ1 and DZ2 provide power to the gripper; when the doors close, RG1 and RG2 energize. As the car leaves the floor DZ1 and DZ2 de-energize, power to the “ROPE GRIPPER®” is maintained through RG1 and RG2. When approaching a new floor DZ1 and DZ2 again energize, when the doors open RG1 and RG2 de-energize.

OVERSPEED

- When an overspeed is detected, the Governor overspeed switch opens. Additional overspeed can be detected by use of an encoder or tachometer that detects the speed of the elevator. (Not the motor or worm shaft of a geared elevator.) When detected, relays RG1, RG2, DZ1 and DZ2 de-energize. This removes power from the “ROPE GRIPPER®”, gripping the ropes and stopping the car.

OVERSPEED RESET

- Overspeed reset is accomplished by resetting the Governor overspeed switch and possibly the elevator control circuits. Refer to and follow the controller manufacturer’s instructions for “ROPE GRIPPER®” reset.

IMPORTANT: The code requires that the “ROPE GRIPPER®” be manually reset if it is triggered by fault. It is intended that a qualified technician inspect for, and correct any, malfunction before the car is placed back into service. A dangerous situation can be produced if a gripper is manually reset without first correcting the cause of the fault.
eg: If there has been a brake failure that has not been corrected, when the gripper is reset, it is very likely that the car will fall either up or down.

UNINTENDED MOTION

- When at the floor with the doors not in the closed position, relays RG1 and RG2 are de-energized and relays DZ1 and DZ2 are energized. If the car leaves the floor, DZ1 and DZ2 de-energize, removing power from the “ROPE GRIPPER®”, gripping the ropes and stopping the car.

UNINTENDED MOTION RESET

- Unintended motion reset is accomplished through elevator control circuits. Refer to and follow the control manufacturer’s instructions for “ROPE GRIPPER®” reset.

IMPORTANT: The code requires that the “ROPE GRIPPER®” be manually reset if it is triggered by fault. It is intended that a qualified technician inspect for and correct any malfunction before the car is placed back into service. A dangerous situation can be produced if a gripper is manually reset without first correcting the cause of the fault.

eg: If there has been a brake failure that has not been corrected, when the gripper is reset, it is very likely that the car will fall either up or down.

MANUAL OPENING

- During a power failure the “ROPE GRIPPER®” will activate. When power is restored the gripper will automatically reload and put the elevator back into service. If the car is to be moved during a power outage, a manual pump is provided to open the “ROPE GRIPPER®”.
- Turn the valve stem (**Figure 4**) in the pumping unit to MANUAL. Use the hand pump to move the “ROPE GRIPPER®” towards the loaded position releasing the ropes. If the hydraulic valve is left in the manually closed position, when power is restored a microswitch contact will prevent the elevator from running.

CAUTION: DURING THE FOLLOWING TESTS PASSENGERS SHOULD BE PREVENTED FROM ACCESS TO THE ELEVATOR

TEST PROCEDURE FOR COMPLIANCE WITH ELEVATOR SAFETY CODES

THE ROPE GRIPPER® MUST BE TESTED TO MEET ALL REQUIRED CODES

IN ADDITION TO THE TESTS BELOW, THE CONTROL MANUFACTURER MAY HAVE ADDITIONAL TEST RECOMMENDATIONS

1) POWER INTERRUPTION TEST

Run the car in slow speed and turn the toggle switch on the side of the pump unit to OFF. This will activate the “ROPE GRIPPER®” causing it to grip the ropes and stop the car. When the gripper is activated, the “ELEVATOR CAN RUN” contact will open and signal the controls to interrupt power to the driving motor and machine brake.

DURING THE FOLLOWING 2 TESTS, ALLOW THE BRAKE TO STOP THE CAR IF THE “GRIPPER” DOESN’T. When activated by either of these tests, the “Gripper” circuits must be manually reset.

2) ASCENDING CAR OVERSPEED TEST

With an empty car, overspeed (approximately 10% over contact speed) the car in the “UP” direction while keeping the machine brake open. The Governor overspeed switch will activate the “ROPE GRIPPER®”. The gripper will stop the car before the counterweight strikes the buffer or, at least, reduce the car speed to the speed for which the buffer is designed. If it is impractical to overspeed the car, run the empty car up at high speed with the machine brake held open and manually trip the Governor overspeed switch. The gripper will cause the car to slow down and stop. The Governor can then be tested to make sure the Governor switch opens at the correct overspeed setting.

3) UCM - UNCONTROLLED CAR MOTION TESTS

CAUTION: DO NOT ALLOW ANYONE TO ENTER THE ELEVATOR DURING THIS TEST!!!

- a) With the car at a floor with the doors partially open (not fully opened), open the machine brake. (With empty car the elevator moves up, with full load the elevator moves down.) The “ROPE GRIPPER®” should apply and stop the car within 48” (1220 mm).
- b) Repeat test “a)” with the doors fully open. The “ROPE GRIPPER®” should apply and stop the car within 48” (1220 mm).

- c) Register a call and as the car approaches the floor hold the brake open.
For all tests, as the car drifts from the floor with a partially or fully open “ROPE GRIPPER®” should apply and stop the car within 1220 mm (48"). If the car does not move when the machine brake is opened, the brake drum or disc can be turned to start the car.

SUGGESTED ADDITIONAL SOFTWARE FOR ADDED SAFETY

1. If the machine brake fails to drop when at the floor, (as indicated by the brake switch) the "GRIPPER" can be activated. In this case the car need not leave the door zone to apply the "GRIPPER".
2. In addition to the overspeed switch on the governor, the "GRIPPER" can apply when any device in the system indicates overspeed, such as an encoder, tachometer and/or an emergency terminal stopping device.
3. The "GRIPPER" can be applied when any unintended motion is detected, such as the car moving without a signal to run, or the car moving up with a down signal and visa-versa.

ROPE GRIPPER® TROUBLE SHOOTING GUIDE

WARNING! KEEP HANDS CLEAR OF ROPE GRIPPER. FORCES CREATED CAN CRUSH FINGERS.

GRIPPER WILL NOT RESET - GRIPPER SET ON ROPES

- Check location of rotating shaft in cam; if rotating shaft tube is against wear-out switch refer to section concerning Lining Replacement
- Check for open Safety circuit.
- Check for blown fuse; refer to that section

GRIPPER DRIFTING CLOSED, CONTINUOUS RELOADING, PUMP UNIT CYCLING ON AND OFF

These are all indications that the Rope Gripper latch is not holding the Rope Gripper open. Read and understand this section completely prior to performing any checks.

- First, it should be understood that the “ROPE GRIPPER®” is hydraulically pumped open to the “Ready” or “Loaded” position, and thereafter held electro-mechanically with a latching coil assembly (**See Figure 5**).
- When the gripper rotating shaft reaches the loaded position, the Brake-Ready microswitch contact will open turning off the pump. The pump should run just long enough to get the latch hook past the trigger, and then shut off. The hydraulic pressure may slowly bleed off until trigger and latch are resting together. At this point, the trigger and latch should be engaged as shown in **Figure 5**.
- Many problems can be traced back to the gripper not latching properly. Latch engagement problems are typically a result of:
 - 1) Dirty latch assembly (blow out with compressed air),
 - 2) Brake-Ready microswitch out of adjustment, causing mis-engagement of the trigger and latch,
 - 3) Improper latch coil pressure (**See Separate Bulletin 1164**) or less commonly,
 - 4) A malfunctioning latch coil, or
 - 5) Misalignment (side to side) of the latch.

Any of the above will be indicated by the Pumping Unit cycling on and off. This cycling could be as quick as every 15 seconds or so, to as long as every couple of minutes. Repeated cycling may cause unnecessary wear on the cylinder and pump unit, requiring premature maintenance, fluid loss (cylinder leaks), and can cause motor and/or capacitor failure.

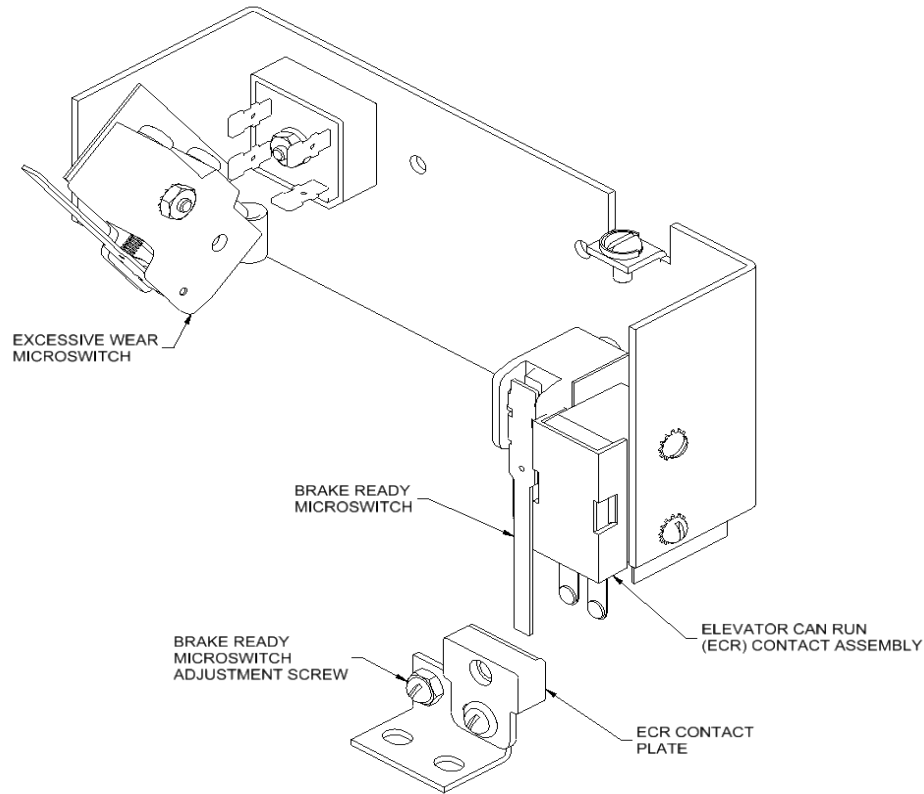

Current Switch Assembly 620 or 622-064, ECR Contact Plate 618-067, Actuating Angle 600-051

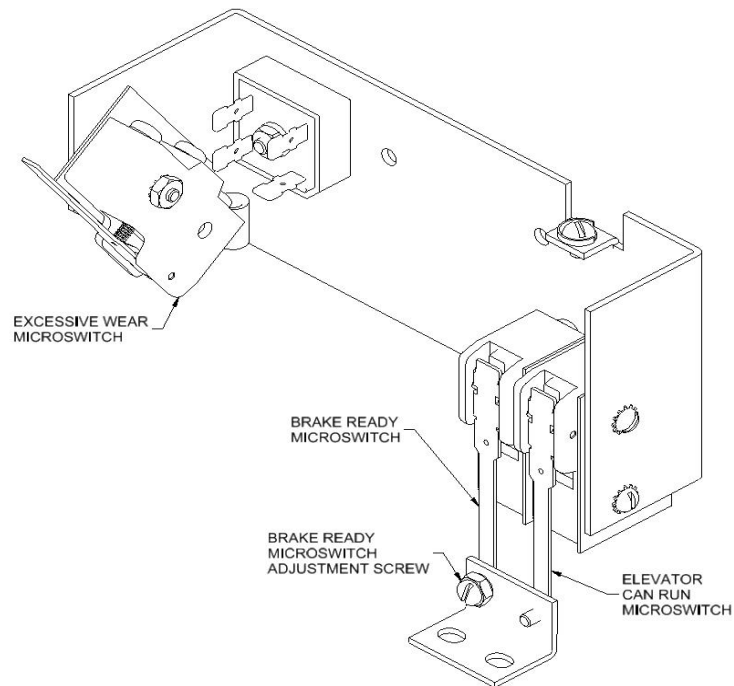

Older Style Switch Assembly (Parts List Page 37): 620 or 622-050, Actuating Angle 600-051

- The Brake-Ready microswitch (**Figure 7**) should be adjusted to allow proper engagement of the trigger and latch and to prevent the rotating shaft from bottoming out in the cam slot. There should be approximately 1/32" clearance between the rotating shaft and the bottom of the cam slot when the trigger and latch are engaged. In other words, the pump must run long enough to allow the trigger and latch to properly engage, yet not so long as to push the rotating shaft into the back of the cam slot.
- After “ROPE GRIPPER[®]” installation or after any maintenance check, it is suggested that the in-service gripper be observed for 15 minutes or so to assure proper operation.

MICROSWITCH ADJUSTMENT PROCEDURE – Read and understand this section completely prior to performing any checks.

1. To check adjustment, first switch pumping unit OFF. This will activate the “ROPE GRIPPER[®]” and grip the ropes. Note the position of the large washer and Allen Screw on top of the latch coil (see **Figure 5**).
2. Switch pumping unit ON. This will return “ROPE GRIPPER[®]” to the “READY” position. While returning to the ready position, watch the large washer at the top of the latch coil. The washer (and Allen Screw) should rise with the passing of the latch under the trigger, then lower and return to its original position. If it does, move on to Step 5.
3. If the washer did not return to the fully seated position, either a.) the pump is not running long enough, indicating microswitch out of adjustment, or b.) as has happened on *very* rare occasions, the latch is slightly out of adjustment causing the trigger to bind on one edge of the latch. Visually, when the trigger and latch engage, you should see run-by clearance between the sides of the latch and the trigger, and the latch should be fairly well centered on the trigger. Run Steps 1 & 2 again to check your results. If the latch is centered, move on to Step 5.
4. *If the latch is not centered, you should consider calling Hollister-Whitney Technical support.* To center the latch, first switch pumping unit OFF. This will activate the gripper and grip the ropes. Slightly loosen screws holding latch, and tap latch into a more centered location, making sure the latch remains square. Retighten screws and repeat Steps 1 & 2.
5. Re-install the security screws so that they just touch the rotating shaft.
6. At this point, the coil should be activated. If the large washer and Allen Screw are seated properly, it should not be possible to raise the washer and Allen Screw with thumbnail pressure. If you can raise the washer, check all power to and across the coil. If there is a problem with the power or the coil, repair it now and move on to Step 9.
7. Remove one or both of the connecting arms from the gripper. Check the clearance between the rotating shaft and the cam slot (approximately 1/32”, see **Figure 5**), and reinstall the connecting arm(s). Note: If clearance approaches zero, contact Hollister-Whitney Technical support.
8. Older style switch assemblies have two screws in the Actuating Angle, while current production has one and a contact bar. (See **Figures 7 & 8**). Locate the Brake-Ready Microswitch Adjustment Screw. To make the pump run longer, adjust the screw outwards in ¼ turn increments. **WARNING: It is advised that you check the rotating shaft/cam slot clearance after each adjustment by repeating this procedure.** Additionally, if 1 full turn (4 adjustments or 4 x ¼) has been made to the microswitch and the washer seems to be fully seated but still moves up with no improvement, see **Bulletin 1164** (Setting Rope Gripper Latch Pressure) found at: <http://www.hollisterwhitney.com/support/> and call Hollister-Whitney for additional technical support.
9. Remove the security screws and retest the “ROPE GRIPPER[®]” to check adjustment.

White	RG2
Black	RG3
Red	RG4
Orange	RG5
Blue	RG6
Green	Ground

Pigtail to Pumping Unit Wiring Chart 2

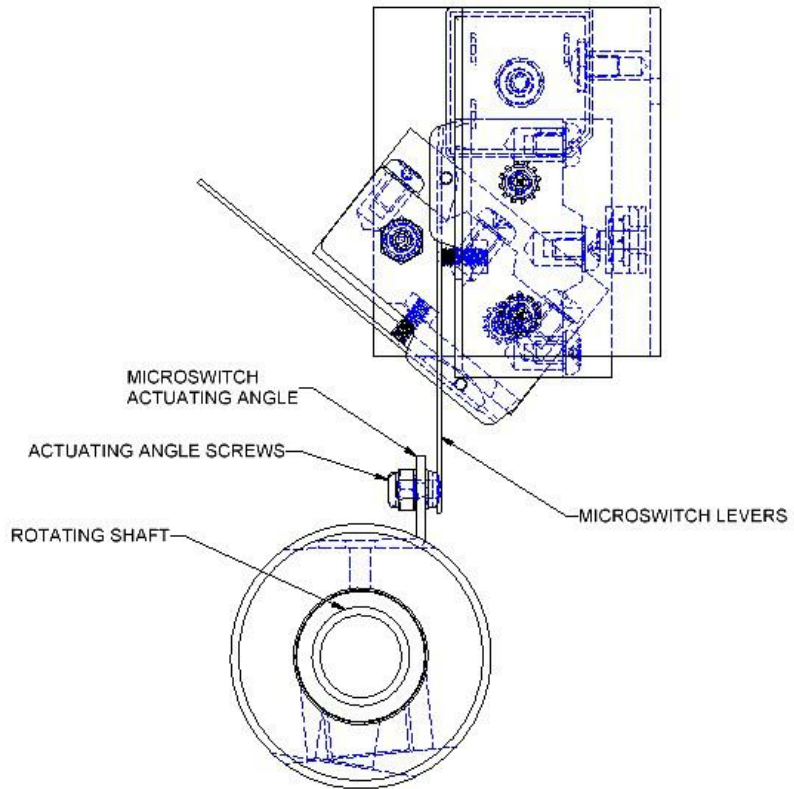

FIGURE 8

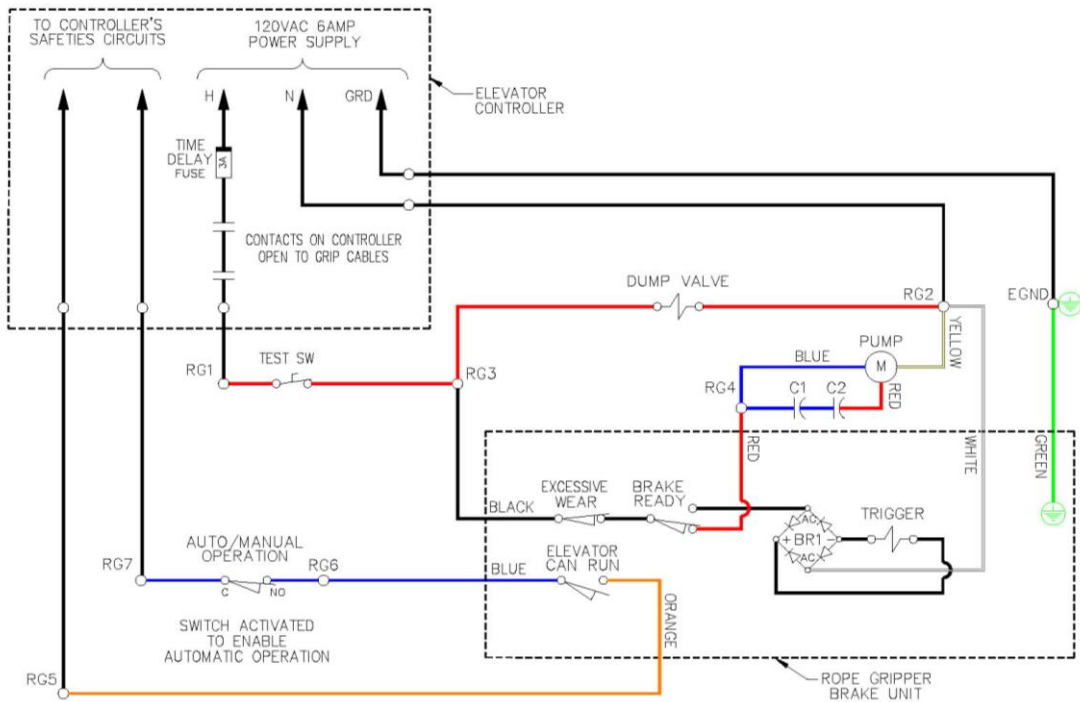

DIAGRAM 4

BLOWING CONTROLLER FUSES – Read and understand this section completely prior to performing any checks.

- Check type of fuse being used. **Note:** Hollister-Whitney specifies a 3 amp Fusetron fuse, which is a dual element time delay fuse. (**Diagram 4**). Many controller manufacturers have not supplied this fuse. If the fuse is not correct, consult with your controller manufacturer. A 4 Amp MDL or 5 Amp MDL fuse may be substituted but only with the approval of your controller manufacturer. If the fuse is correct, see **CHECKING PUMP UNIT AMP DRAW** below.
- Electric Pump runs, but Gripper does not open. First check hydraulic oil level. Refer to **FLUID LEVEL LOW** line item below. If the pump runs too long at low fluid levels, the fuse may blow, and in some cases, the pump, motor and/or motor capacitors may fail.
- Check resistance of the Dump Valve Coil. Resistance should not be “open” it should be about 0.5 Mega Ohms. If you obtain an “open” reading, replace the Dump Valve Coil.
- If Fluid Level, Dump Valve Coil, and Amp Draw are OK, place the Dump Valve in the Manual position and run the pump. If the gripper opens with the pump running and the valve in manual position, replace the Dump Valve.

CHECKING PUMP UNIT AMP DRAW

1. Make sure the security set screws are installed or that the “ROPE GRIPPER®” is clamped to the ropes.
2. Switch the pump unit OFF.
3. Disconnect the power supply from the controller at RG1 and RG2 on the Pumping Unit.
4. Disconnect hydraulic line from “ROPE GRIPPER®” at the Quick Connect.
5. Get an extension cord and remove the female end. Bare the wire ends and connect cord L1 to RG1 and cord L2 to RG2. Plug the extension cord into a 120 VAC wall outlet. Put a Clamp-on Amp Meter around cord L1 and switch the pump unit ON. The pump motor should run. (NOTE: It may be necessary to jump out RG3 and RG4 to get pump unit to run.) After the initial high spike, you should see the amp draw drop and level out to no more than **7 amps**. 7A or less will indicate that there is no problem with your pump unit and you should consult with your controller manufacturer. If your Amp Draw is more than this value, call Hollister-Whitney Technical Support for assistance at 217-222-0466.

AIR IN LINE (CHANGING OUT HOSES OR CYLINDERS)

Air can be introduced if replacing the hydraulic hose or cylinder. This air can cause complete failure of the resetting/reloading mechanism and must be bled.

- Prior to air bleeding, check that manual pump is operational, with valve stem at MANUAL and Quick-Connect disconnected. If lever has no, or little, resistance see manual for priming hand pump. If OK, place valve stem at AUTOMATIC, reconnect hose and extend cylinder fully.
- CYLINDER without Bleeder Valve: To bleed air, first loosen the hose swivel connection at cylinder, then use hand pump until no air is evident. Re-tighten hose.
- CYLINDER with Bleeder Valve: A Bleeder port has been provided next to the oil inlet. Use this port to bleed air when changing a hose or cylinder.

HYDRAULIC CYLINDER REPLACEMENT INSTRUCTIONS *NOTE:* **Read and understand instructions prior to cylinder replacement!!! It is highly recommended that the mechanic have a long handled (7” long) 5/32” Ball End Allen wrench or driver in his kit, in addition to the normal mechanics tools including wrenches, screw drivers and Allen wrenches.**

➤ **Situation 1: Leaking Cylinder**

1. Pump “ROPE GRIPPER®” into the LOADED or Ready position and install security screws to hold gripper shoes open.
2. Remove 4 snap rings, both connecting arms and movable shoe.

3. Turn pumping unit OFF and place valve stem in the MANUAL position. Using hand pump, pump cylinder down just enough to relieve pressure on security screw. Remove security screws.
4. Return valve stem to the AUTOMATIC position. The rotating shaft will go entirely up the cam. At this time, with the rotating shaft at the top of the cam, remove the hydraulic hose from the cylinder.
5. Remove 3 angle bolts from both sides of mounting angle, leaving mounting angles attached to floor (Gripper Mounting Channels).
6. Place "ROPE GRIPPER[®]" on a suitable work surface. Locate the shaft holding the cylinder and remove shaft from gripper.
7. Locate the block holding the cylinder stem to the rotating shaft tube. Using a long 5/32" Ball Nose Allen Wrench, remove (4) 10-32 screws from block. Remove block from cylinder.
8. Put block on new cylinder. Re-install cylinder by installing shaft first, then block and screws. Install hose on cylinder. Restore "ROPE GRIPPER[®]" to mounting angles.
9. With valve stem at MANUAL, bleed air out of system per above "AIR IN LINE" section until no air is evident.
10. Turn pumping unit ON. Hand pump cylinder down until pump motor takes over pumping. With rotating shaft down and trigger latched, install security set screws.
11. Re-assemble moveable shoe, arms, and snap rings to "ROPE GRIPPER[®]". When complete, remove security set screws, turn valve to AUTOMATIC and place gripper back into operation.

➤ **Situation 2: Cylinder will not pump down (or hold pressure)**

1. Make sure "ROPE GRIPPER[®]" is gripping ropes, the pumping unit is OFF and machine brake is set.
2. Remove 5 angle bolts from both mounting angles and set mounting angles aside.
3. Locate the shaft holding the cylinder and remove shaft from "ROPE GRIPPER[®]".
4. With valve stem on MANUAL, follow instructions 7., 8. and 9. above.
5. Return valve stem to AUTOMATIC and turn pumping unit ON. Gripper will return to loaded or open position.

FLUID LEVEL LOW – Gripper pumps partially down, pump continues to run

- With the "ROPE GRIPPER[®]" in the loaded position, the level should fully cover the Oil Level Window on the Oil Reservoir. Use **SHC524 Mobil 1 Synthetic Hydraulic Oil** or **Mobil 1 Fully Synthetic ATF (Automatic Transmission Fluid)** to top off oil level.

HAND PUMP DOES NOT FUNCTION (AIR LOCK) GRIPPER WILL NOT PUMP OPEN MANUALLY

- Check oil level and top off as necessary.
- Disconnect the Hydraulic hose from the gripper at the Quick-connect coupling.
- Put Dump Valve in manual position and lower the hand pump handle.
- Run pumping unit electrically. The hand pump handle should rise. This should prime the hand pump and force fluid into the system, allowing proper use of the hand pump.
- This procedure may need to be repeated a few times to effectively prime the pump system.

"ROPE GRIPPER[®]" LUBRICATION

- Apply a thin layer of a general purpose grease lubricant to the cam surface, the trigger and latch mechanism, and the four movable shoe guides.

WIRE ROPE LUBRICATION

- Use a high friction lubricant such as: NYLUBE CABLE CARE #65 or AMERICAN OIL VITALIFE #600. Care should be taken not to over lubricate



Certificate of Compliance

Certificate: 1002290 Master Contract: 155941 (088181_0_000)
 Project: 70127541 Date Issued: 2017-05-12
 Issued to: Hollister-Whitney Elevator Corporation
 2603 North 24th St
 Quincy, Illinois 62305
 USA
 Attention: Chintan Sheth

The products listed below are eligible to bear the CSA Mark shown with adjacent indicators 'C' and 'US' for Canada and US or with adjacent indicator 'US' for US only or without either indicator for Canada only.



Issued by: *Kevin Chieu*
 Kevin Chieu

CSA B44.1/ASME A17.5

PRODUCTS

CLASS - C241101 - ELEVATOR EQUIPMENT-Open and Enclosed-Elevator Electrical Equipment
 CLASS - C421181 - MOTORS AND GENERATORS-Certified to US Standards

"Rope Gripper", Models 600, 601, 605 and 610 (with pumping unit), electrical rating: 6A, 120Vac 60Hz, single phase, contact rating 250Vac, 6A/250Vdc, 0.15A

"Rope Gripper", Models 618, 620, 622, 624, 625, 626 and 626 SPL (with pumping unit), electrical rating: 6A, 120Vac, 60Hz, single phase, contact rating 250Vac, 6A/250Vdc, 0.15A

APPLICABLE REQUIREMENTS

CSA B44.1/ASME A17.5 - Elevator and Escalator Electrical Equipment



Supplement to Certificate of Compliance

Certificate: 1002290 Master Contract: 155941 (088181_0_000)

The products listed, including the latest revision described below, are eligible to be marked in accordance with the referenced Certificate.

Product Certification History

Project	Date	Description
70127541	2017-05-12	Update report for alternate construction, addition of alternate contacts for ready switch.
70086186	2016-12-14	Update report to cover alternate solenoid and under voltage re-test.
70066621	2016-05-11	Update report to cover alternate construction and re-testing of solenoid under voltage test
2556088	2012-10-23	Alternative rectifier; Moved mechanical and EC type certification information to Attestation report 2563004.
1547818	2005-01-13	Addition of rope gripper model 626-SPL(LR 88181-2)

EU-TYPE EXAMINATION CERTIFICATE

Issued by Liftinstituut B.V.
 identification number Notified Body 0400,
 commissioned by Decree no. 2018-0000125182

Certificate no. : NL01-400-1002-020-03 Revision no.: 7

Description of the product : "Rope Gripper", certified as stopping element of ascending car
 overspeed protection and/or unintended car movement protection

Trademark, type : "Rope Gripper", Models 618, 620, 622, 624, 625 and 626(SPL)

Name and address of the manufacturer : Hollister-Whitney Elevator Co., LCC GumYoung General Co., Ltd.
 P.O. Box 4025 60, Donyu 1-ro, Paju-eup,
 2603 North 24th Street Paju-si, Gyeonggi-do
 Quincy, Illinois 62305, USA 10832, Republic of Korea

Name and address of the certificate holder : G.A.L. Manufacturing Company, LCC
 50 East 153rd St., Bronx, NY 10451, USA

Certificate issued on the following requirements : Lifts Directive 2014/33/EU

Certificate based on the following standard : EN 81-1:1998+A3:2009
 EN 81-20/50:2014

Test laboratory : CSA International, Toronto, Canada
 Hollister Whitney, Quincy, Illinois, USA

Date and number of the laboratory report : August 25, 2009; CSA 155941-1002290 (LR 88181-2) Edition 10
 November 4, 2010; CSA 155941- 2308945 (LR 88181-2) Ed.1
 March 24, 2015; CSA Project 70015005 rev.5

Date of EU-type examination : Rev. 7; August 30, 2018

Additional document with this certificate : Report belonging to the EU-type examination certificate
 no.: NL01-400-1002-020-03 rev.7

Additional remarks : None

Conclusion : The safety component meets the requirements of the Lifts Directive
 2014/33/EU taking into account any additional remarks mentioned
 above.

Amsterdam

Date : 30-08-2018
 Valid until : 31-08-2022



ing. P.J. Peeters
 Manager



Certification decision by

PARTS LIST			DESCRIPTION
ITEM	QTY	PART NUMBER	
1	1	620-003	STATIONARY SHOE ASSEMBLY
2	1	620-004	MOVABLE SHOE
3	2	620-007	SHAFT SUPPORT BLOCK
4	4	620-008	SPACER (11 GA.) - LINING WEAR
5	2	620-008-1	SPACER (16 GA.) - LINING WEAR
6	2	620-008-2	SPACER (22 GA.) - LINING WEAR
7	1	620-015	TUBING ASSEMBLY
8	2	620-018	ROTATING & NON-ROTATING SHAFT
9	2	601-020	CONNECTING ARM ASSEMBLY
10	2	601-022	LINING ASSEMBLY
11	2	601-025	LOWER SPRING GUIDE ASSEMBLY
12	2	601-027	SPRING UPPER SUPPORT
13	2	601-029	SPRING UPPER SUPPORT GUIDE
14	2	601-030	GRIPPER SPRING
15	2	620-031	SHAFT
16	2	620-032	SPACER TUBING
17	1	620-033	TUBING - SPACER
18	1	601-035	CYLINDER - ASSEMBLY
19	1	622-036	HYDRAULIC CYLINDER PIVOT BRACKET ASSEMBLY
20	1	620-037	HOSE - VARIOUS LENGTHS
21	1	620-038	QUICK CONNECT FITTING
22	1	601-039	1/8" X 1/4" NPT, 90° ELBOW
23	1	620-040	COVER - 620 ROPE GRIPPER
24	1	601-041 R	MOUNTING ANGLE - RIGHT
25	1	601-041 L	MOUNTING ANGLE - LEFT
26	1	600-051	ACTUATING ANGLE w/SCREWS
27	1	620-064	SWITCH ASSY (LEAD LENGTHS, -1 = 10', -2 = 24', -3 = 18')
28	1	618-067	CONTACT PLATE ASSEMBLY
29	1	601-078	LATCH
30	1	600-081	CONDUIT - FLEXIBLE (1/2")
31	1	600-082	801-DC2 90° ANGLE BOX CONNECTOR
32	1	610-087	90° ADAPTOR, 45° FH 5/8"-18 X 1/4 NPT 18
33	1	610-091	3-8 X 3-8 NPT STREET 90 DEG. ELBOW
34	2	601-095	DOUBLE BOLT WASHER
35	1	620-607	SOLENOID LOCKING UNIT
36	4	90-033	E-CLIP, #X5133-74
37	1	P-139	ROPE GRIPPER WARNING LABEL - SMALL
38	1	P-133	ROPE GRIPPER WARNING LABEL - MEDIUM
39	1	P-137	GRIPPER LUBE INST. STICKER
40	1	P-141	IMPORTANT LABEL - APPLIED TO TUBING
41	1	P-143	620 ROPE GRIPPER LABEL
42	1	P-144-2	AIR BLEED LABEL
43	2	P-186	ROPE GRIPPER WEAR-IN LINE STICKER
44	1	P-192	IMPORTANT NOTICE - LANG LAY ROPES, ROPE GRIPPER
45	6	1/2 - 13 UNC x 1.25	HEX HEAD CAP SCREW
46	6	1/2 LOCK WASHER	STANDARD LOCK WASHER
47	4	5/16 - 18 UNC x 2.0	SOCKET HEAD CAP SCREW
48	4	5/16 WASHER	STANDARD LOCK
49	2	#10-32 UNF x 0.375"	SOCKET HEAD CAP SCREW
50	2	#10-32 UNF x 0.75	SOCKET HEAD CAP SCREW
51	8	#10 LOCK WASHER	STANDARD LOCK WASHER
52	1	10-32 UNF x 0.25	SET SCREW
53	2	1/4 - 20 UNC x 1.5	HALF DOG SET SCREW
54	4	#10-24 UNC x 0.5	SOCKET HEAD CAP SCREW
55	6	#10-24 UNC x 0.5	WHIZ BOLT
56	1	#6-32 UNCX0.3125	BRASS MACHINE SCREW
57	1	#6 WASHER	STANDARD WASHER
58	1	620-100	PUMPING UNIT
59	1	622-207	HOSE GROMMET

Weight - Pumping Unit: 29.2 lbmass, Gripper: 63.267 lbmass	
HOLLISTER-WHITNEY	
ELEVATOR CO. LLC	
LTL	COLLECTOR CORRECTED
11/5/13	PUR #627
11/5/13	REDRAWN; PUR #594
B/LG	
8/24/10	REVISED PART
8/24/10	PUR #383
1/15/09	DRAWN SCALE MATERIAL
4/4/08	PUR #377
1/2/07	PUR #359
C	DATE
9/8/2003	DATE
C	SEE PARTS LIST
	REFERENCE TO: ALL UNLESS OTHERWISE SPECIFIED
	620
	SHEET 1 OF 2

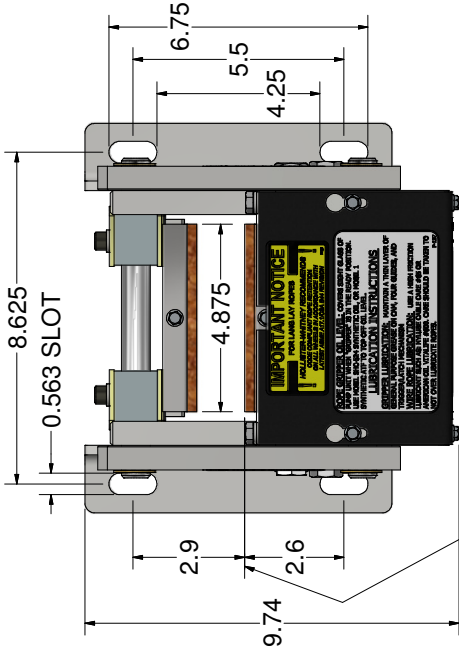
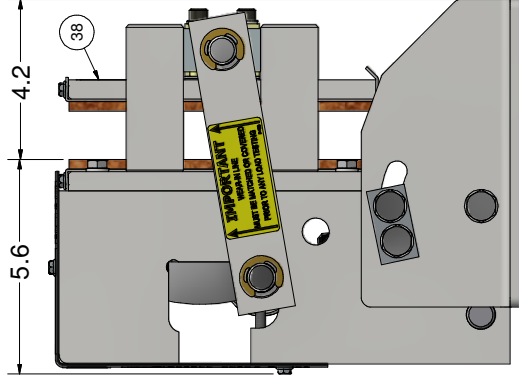
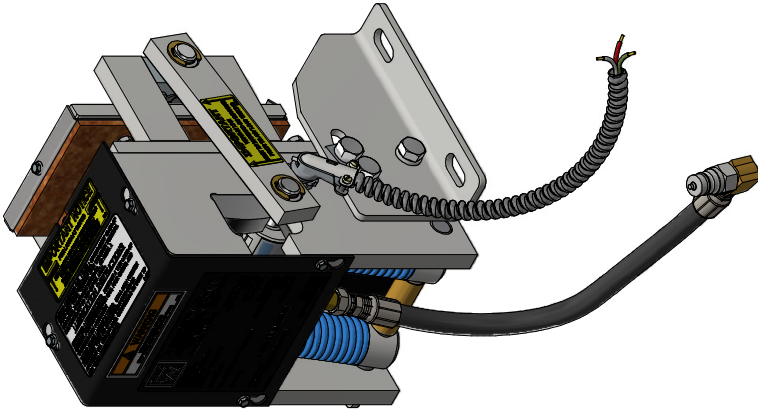

PAD POSITION REFERENCE;
CENTERLINE OF ROPE WILL
VARY WITH ROPE SIZE

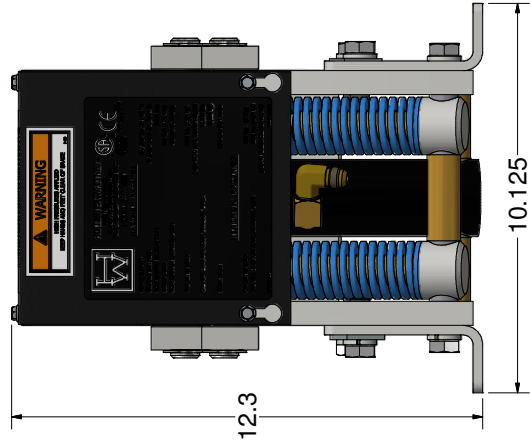

NOTE:

- QTY LISTED FOR ITEMS 4, 5 & 6 ARE STANDARD. ACTUAL QTY MAY VARY WITH ROPE DIAMETER.
- REFERENCE DIMENSIONS SHOWN TO AID IN SETUP AND INSTALL

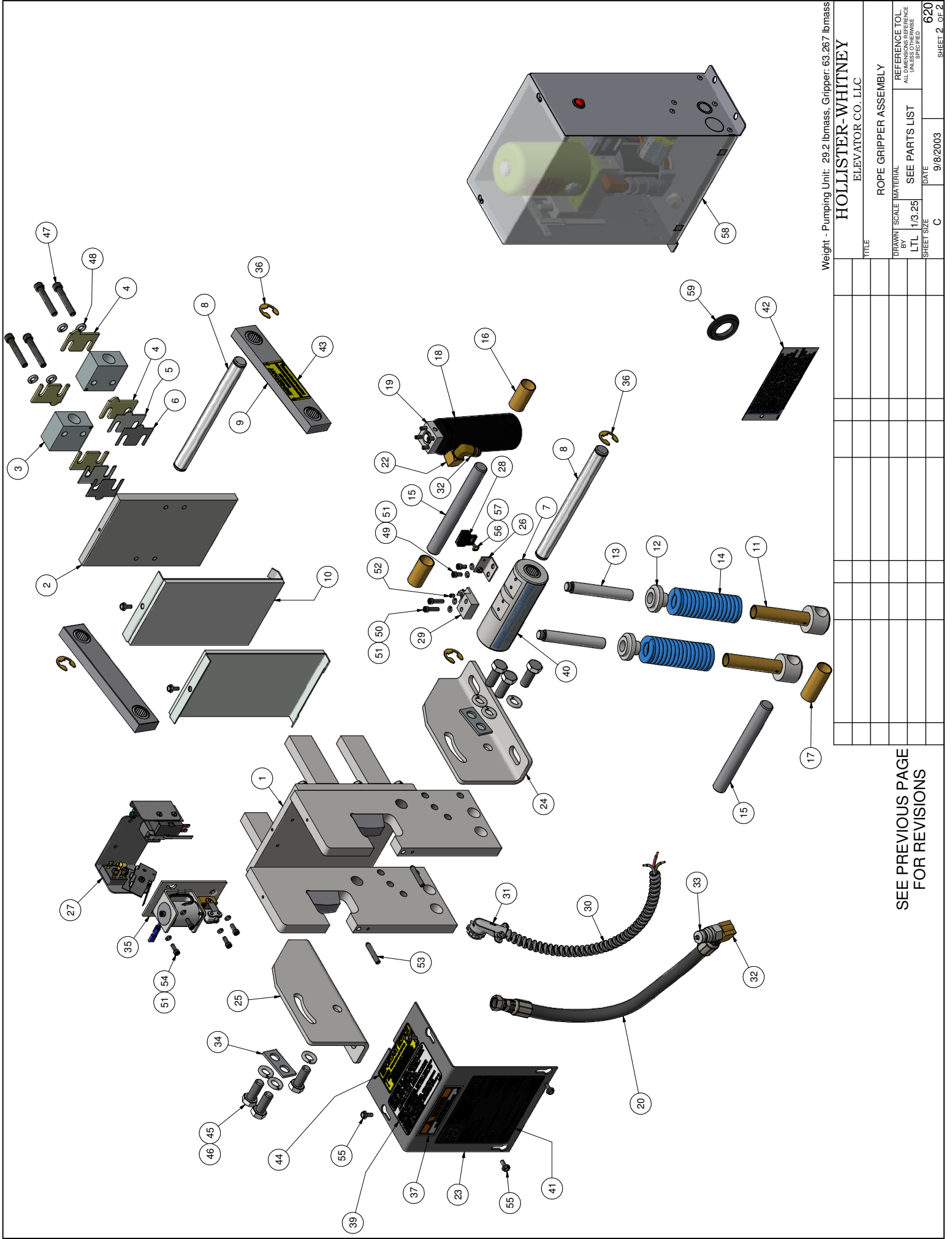

Weight - Pumping Unit: 29.2 lbmass, Gripper: 63.267 lbmass

TITLE	
HOLLISTER-WHITNEY	
ELEVATOR CO., LLC	
ROPE GRIPPER ASSEMBLY	
DRAWN	SCALE
BY	MATERIAL
LTL	1/3.25
SEE PARTS LIST	REFERENCE TOL.
DATE	UNLESS OTHERWISE
9/8/2003	SPECIFIED
SHEET SIZE	620
C	
	SHEET 2 OF 2

SEE PREVIOUS PAGE FOR REVISIONS

ITEM	QTY	PART NUMBER	DESCRIPTION
1	1	622-003	STATIONARY SHOE ASSEMBLY
2	2	620-007	SHAFT SUPPORT BLOCK
3	4	620-008	SPACER (11 GA.) - LINING WEAR
4	2	620-008-1	SPACER (16 GA.) - LINING WEAR
5	2	620-008-2	SPACER (22 GA.) - LINING WEAR
6	1	622-015	TUBING ASSEMBLY
7	2	622-018	SHAFT - ROTATING & NON-ROTATING
8	2	600-020	CONNECTING ARM ASSEMBLY
9	2	600-022	LINING ASSEMBLY
10	2	600-025	LOWER SPRING GUIDE ASSEMBLY
11	2	600-027	UPPER SUPPORT - SPRING
12	2	600-029	GUIDE - UPPER SPRING SUPPORT
13	2	600-030	SPRING
14	2	622-031	SHAFT
15	2	601-032	TUBING - SPACER
16	1	622-033	TUBING - SPACER
17	1	600-035	CYLINDER ASSEMBLY
18	1	622-036	HYDRAULIC CYLINDER PIVOT BRACKET ASSEMBLY
19	1	620-037	HOSE - VARIOUS LENGTHS
20	1	620-038	QUICK CONNECT FITTING
21	1	622-040	COVER - 622 ROPE GRIPPER
22	1	600-041 R	ANGLE, RIGHT HAND - MOUNTING
23	1	600-041 L	ANGLE, LEFT HAND - MOUNTING
24	1	600-051	ACTUATING ANGLE w/SCREWS
25	1	622-064	SWITCH ASSY. (LEAD LENGTHS, -1 = 10', -2 = 24', -3 = 18')
26	1	618-067	CONTACT PLATE ASSEMBLY
27	1	622-072	MOVABLE SHOE ASSEMBLY
28	1	601-078	LATCH
29	1	600-081	CONDUIT - FLEXIBLE (1/2")
30	1	600-082	801-DC2 90° ANGLE BOX CONNECTOR
31	1	610-087	PARKER #149F-6-4 MALE ELBOW
32	1	610-091	3-8 x 3-8 NPT STREET 90 DEG. ELBOW
33	2	600-095	WASHER - DOUBLE BOLT
34	1	620-607	SOLENOID LOCKING UNIT
35	4	90-033	E-CLIP, #X5133-74
36	1	P-133	ROPE GRIPPER WARNING LABEL - MEDIUM
37	1	P-134	ROPE GRIPPER WARNING LABEL - LARGE
38	1	P-137	GRIPPER LUBE INST. STICKER
39	1	P-135	622 ROPE GRIPPER LABEL
40	1	P-141	IMPORTANT LABEL - APPLIED TO TUBING
41	1	P-144-2	AIR BLEED LABEL
42	2	P-186	ROPE GRIPPER WEAR-IN LINE STICKER
43	1	P-192	IMPORTANT NOTICE - LANG LAY ROPES, ROPE GRIPPER
44	6	1/2 - 13 UNC x 1.25	HEX HEAD CAP SCREW
45	6	1/2 LOCK WASHER	STANDARD LOCK WASHER
46	4	5/16 - 18 UNC x 2.0	SOCKET HEAD CAP SCREW
47	4	5/16 WASHER	STANDARD LOCK
48	2	1/4 - 20 UNC x 1.5	HALF DOG SET SCREW
49	2	#10-32 UNF x 0.375"	SOCKET HEAD CAP SCREW
50	2	#10-32 UNF x 0.75	SOCKET HEAD CAP SCREW
51	8	#10 LOCK WASHER	STANDARD LOCK WASHER
52	1	10-32 UNF x 0.25	SET SCREW
53	4	#10-24 UNC x 0.5	SOCKET HEAD CAP SCREW
54	6	#10-24 UNC x 0.5	WHIZ BOLT
55	1	#6-32 UNCX0.3125	BRASS MACHINE SCREW
56	1	#6 WASHER	STANDARD WASHER
57	1	620-100	PUMPING UNIT
58	1	622-207	HOSE GROMMET

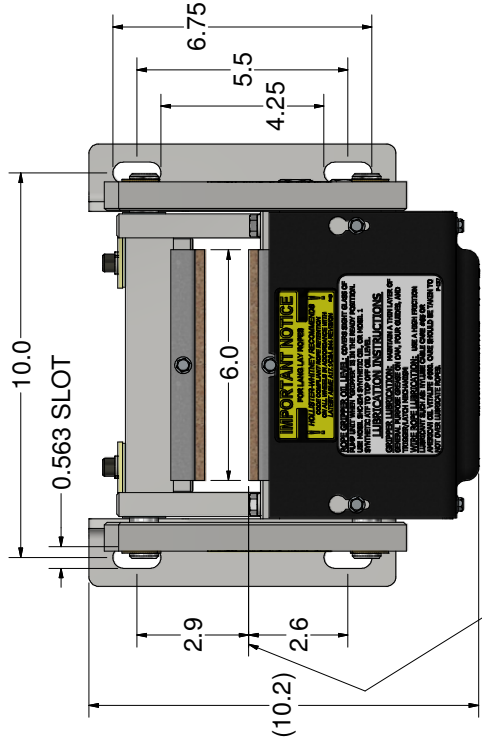
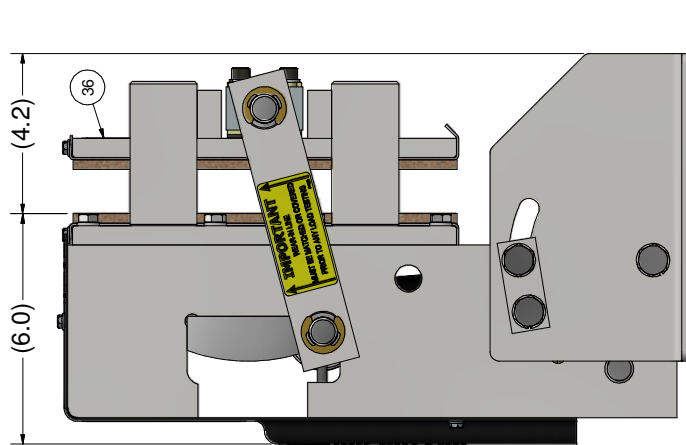
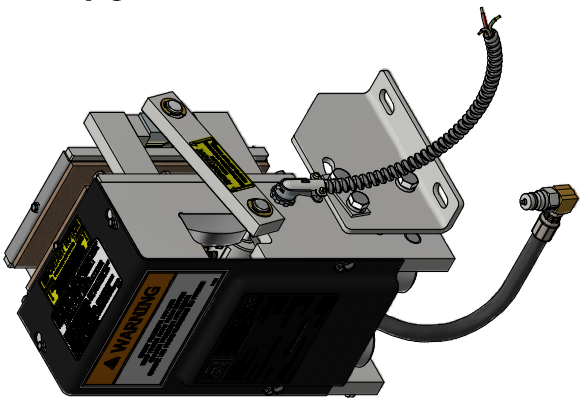

PAD POSITION REFERENCE;
CENTERLINE OF ROPE WILL
VARY WITH ROPE SIZE

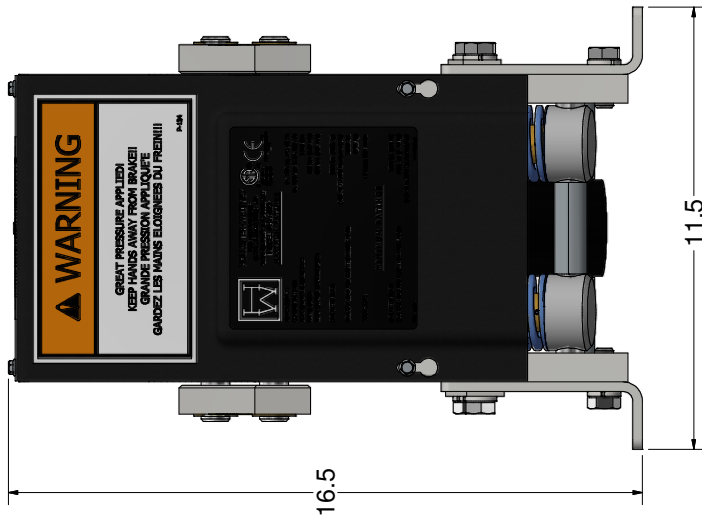

Weight - Pumping Unit: 29.2 lbmass, Gripper: 90.441 lbmass

HOLLISTER-WHITNEY
ELEVATOR CO. LLC

F	ADD PAD POSITION REF.	LTL	10/31/16
	ADD PAD POSITION REF.	LTL	10/31/16
K	620-607 WAS RG-00039N, LTL	5/22/18	
	CAPTURE GROMMET & PUR #637		
	P-144-2, PUR #668		
D	FEDRAW, PUR #584	6/21/13	
C	PUR #426 - REVISE PART BOM NUMBERS	8/24/10	
B	PUR #483	1/15/09	
A	PUR #359	1/2/07	

L	UPDATE P-192, TITLE	LTL	4/5/18
	J BLOCK, PUR #831		
L	622-072, 620-007, 620-008, LTL		
	620-008-1, & 620-008-2		
H	622-084 WAS 822-080 ADD		
	620-067 & P-186, PUR #655		
G	ADD STICKER P-192, PUR LTL	2/9/17	
	620-008-1, & -2, PUR #995		
	#638		

NOTE:

- QTY LISTED FOR ITEMS 3, 4 & 5 ARE STANDARD. ACTUAL QTY MAY VARY WITH ROPE DIAMETER.
- REFERENCE DIMENSIONS SHOWN TO AID IN SETUP AND INSTALL

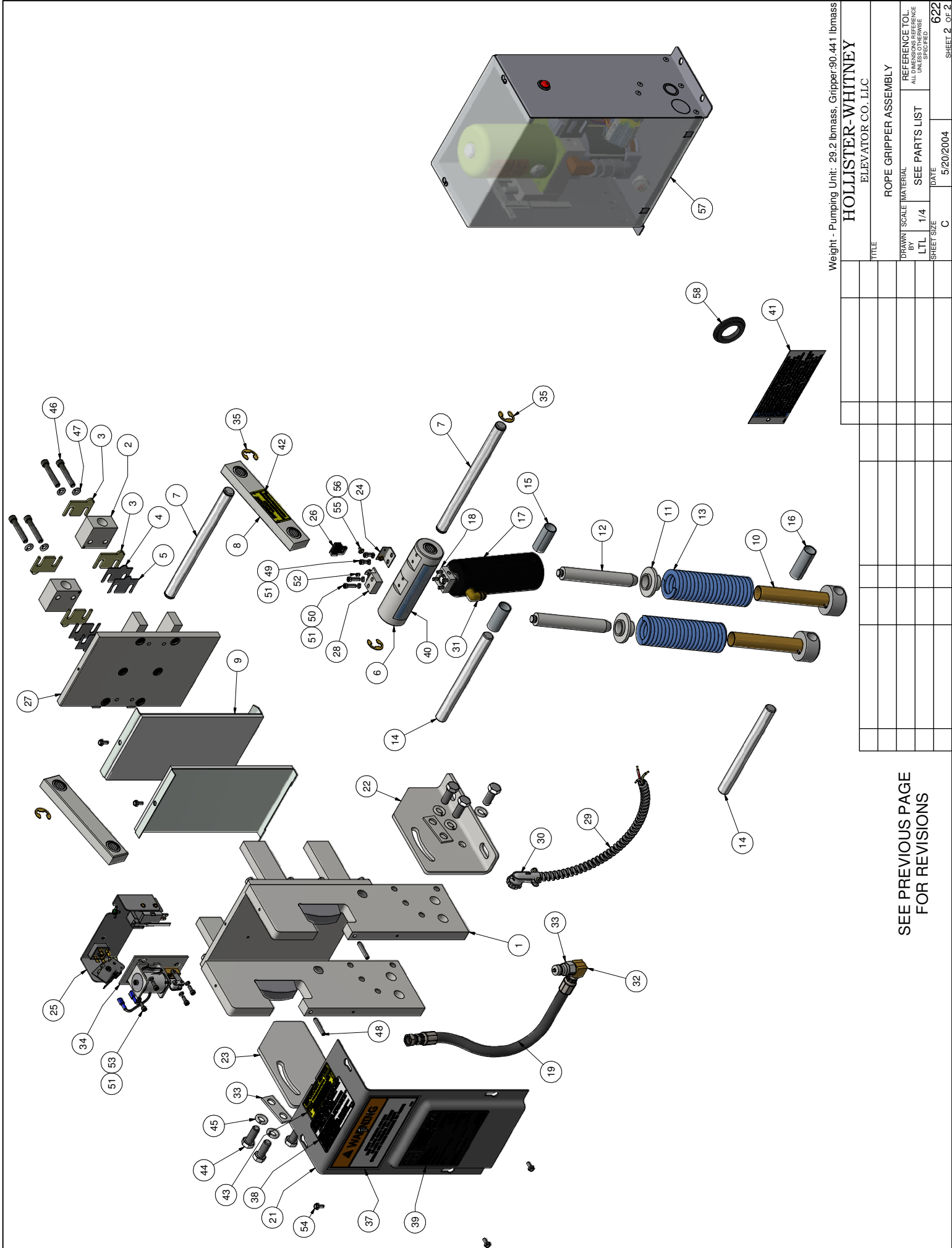

Weight - Pumping Unit: 29.2 lbmass, Gripper: 90.441 lbmass

HOLLISTER-WHITNEY	
ELEVATOR CO., LLC	
TITLE	
ROPE GRIPPER ASSEMBLY	
DRAWN	SCALE
BY	TOL.
LTL	1/4"
SEE PARTS LIST	UNLESS OTHERWISE SPECIFIED
SHEET SIZE	622
DATE	5/20/2004
C	
SHEET 2 OF 2	

SEE PREVIOUS PAGE FOR REVISIONS

ITEM	QTY	PART NUMBER	DESCRIPTION
1	1	624-003	STATIONARY SHOE ASSEMBLY
2	2	624-007	SHAFT SUPPORT BLOCK
3	4	624-008	SPACER (11 GA.) - LINING WEAR
4	2	624-008-1	SPACER (16 GA.) - LINING WEAR
5	2	624-008-2	SPACER (22 GA.) - LINING WEAR
6	1	624-015	TUBING ASSEMBLY
7	2	626-018	SHAFT - ROTATING & NON-ROTATING
8	2	610-020	CONNECTING ARM ASSEMBLY
9	2	610-022	LINING ASSEMBLY
10	2	600-025	LOWER SPRING GUIDE ASSEMBLY
11	2	600-027	UPPER SUPPORT - SPRING
12	2	600-029	GUIDE - UPPER SPRING SUPPORT
13	2	600-030	SPRING
14	2	626-031	SHAFT
15	2	624-032	TUBING - SPACER
16	1	624-033	TUBING - SPACER
17	1	600-035	CYLINDER ASSEMBLY
18	1	622-036	HYDRAULIC CYLINDER PIVOT BRACKET ASSEMBLY
19	1	620-037	HOSE - VARIOUS LENGTHS
20	1	620-038	QUICK CONNECT FITTING
21	1	626-040	COVER - 624 & 626 ROPE GRIPPER
22	1	610-041 R	ANGLE R.H. - MOUNTING
23	1	610-041 L	ANGLE L.H. - MOUNTING
24	1	600-051	ACTUATING ANGLE w/SCREWS
25	1	622-064	SWITCH ASSY (LEAD LENGTHS, -1 = 10', -2 = 24', -3 = 18')
26	1	618-067	CONTACT PLATE ASSEMBLY
27	1	624-072	MOVABLE SHOE ASSEMBLY
28	1	601-078	LATCH
29	1	600-081	CONDUIT - FLEXIBLE (1/2")
30	1	600-082	801-DC2 90° ANGLE BOX CONNECTOR
31	4	610-085	E-CLIP (TRUARC) X5133-98
32	1	610-087	PARKER #149F-6-4 MALE ELBOW
33	1	610-091	3-8 x 3-8 NPT STREET 90 DEG. ELBOW
34	2	610-095	WASHER - DOUBLE BOLT
35	1	620-607	SOLENOID LOCKING UNIT
36	1	P-133	ROPE GRIPPER WARNING LABEL - MEDIUM
37	2	P-134	ROPE GRIPPER WARNING LABEL - LARGE
38	1	P-137	GRIPPER LUBE INST. STICKER
39	1	P-141	IMPORTANT LABEL - APPLIED TO TUBING
40	1	P-142	624 ROPE GRIPPER LABEL
41	1	P-144-2	AIR BLEED LABEL
42	2	P-186	ROPE GRIPPER WEAR-IN LINE STICKER
43	1	P-192	IMPORTANT NOTICE - LANG LAY ROPES, ROPE GRIPPER
44	6	5/8" - 11 UNC x 1.5"	HEX HEAD CAP SCREW
45	6	5/8 WASHER	STANDARD LOCK
46	4	5/16 - 18 UNC x 2.25	SOCKET HEAD CAP SCREW
47	4	5/16 WASHER	STANDARD LOCK
48	2	#10-32 UNF x 0.75	SOCKET HEAD CAP SCREW
49	2	#10-32 UNF x 0.375"	SOCKET HEAD CAP SCREW
50	8	#10 LOCK WASHER	STANDARD LOCK WASHER
51	1	10-32 UNF x 0.25	SET SCREW
52	2	1/4 - 20 UNC x 1.5	HALF DOG SET SCREW
53	4	#10-24 UNC x 0.5	SOCKET HEAD CAP SCREW
54	8	#10-24 UNC x 0.5	WHIZ BOLT
55	1	#6-32 UNC X 0.3125	BRASS MACHINE SCREW
56	1	#6 WASHER	STANDARD WASHER
57	1	620-100	PUMPING UNIT
58	1	622-207	HOSE GROMMET

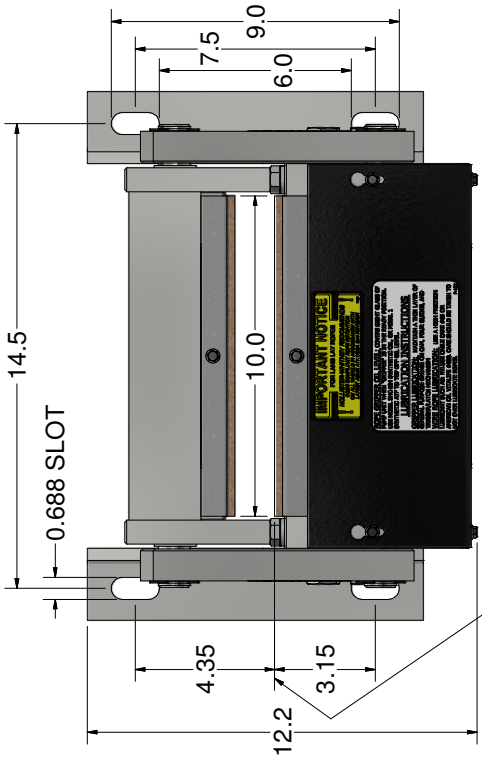
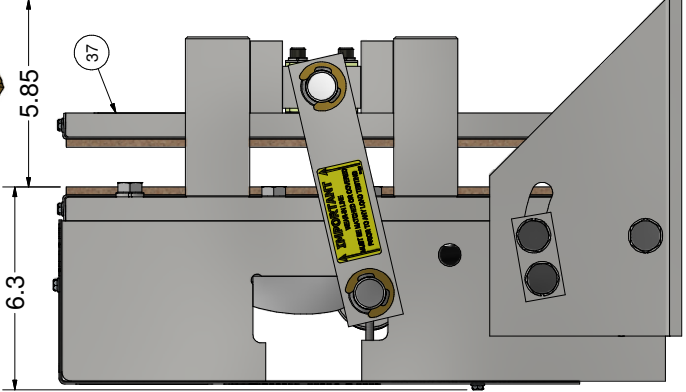
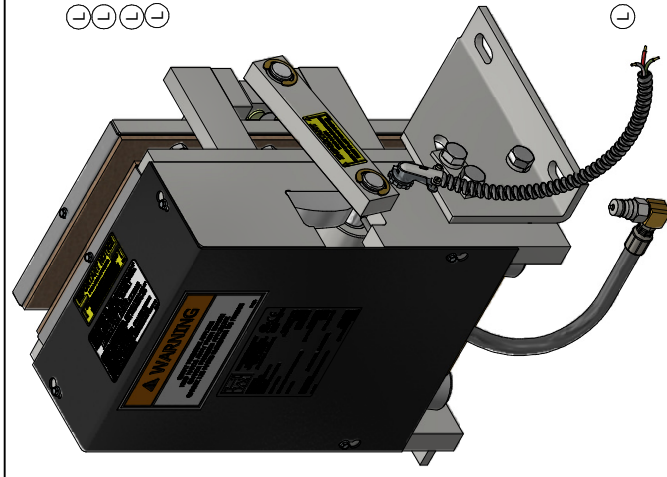

PAD POSITION REFERENCE;
CENTERLINE OF ROPE WILL
VARY WITH ROPE SIZE

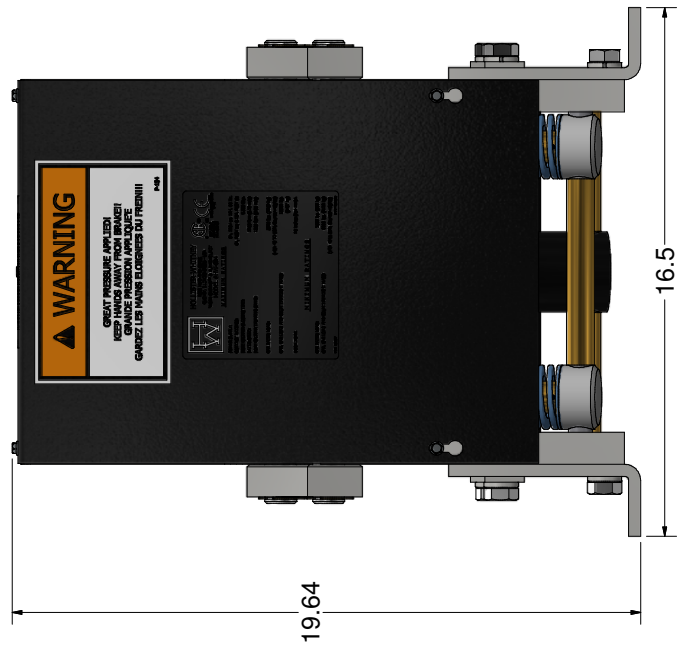

ITEM	QTY	PART NUMBER	DESCRIPTION
F	ADD PAD POSITION REF. LTL	1/06/16	
G	COIL PIN CORRECTED, LTL	11/15/13	
H	BRASS WASHER, PUR#594	6/5/13	
I	REBRAND, PUR#594	6/5/13	
J	REVISED PART BOM	8/24/10	
K	NUMBERS, PUR #426	8/24/10	
L	PUR #433	1/15/09	
M	PUR #359	1/2/07	

Weight - Pumping Unit: 29.2 lbmass, Gripper: 208.274 lbmass	HOLLISTER-WHITNEY
	ELEVATOR CO. LLC
	ROPE GRIPPER ASSEMBLY
	DRAWN SCALE MATERIAL
	BY
	LTL 1/3
	SEE PARTS LIST
	DATE
	10/12/2006
	C
	SHEET 1 OF 2

K	620-607 WAS RG-0030N, LTL	5/22/18
L	CAPSCREW GROMMET & P-144-2, PUR #686	5/22/18
M	UPDATE P-192, TITLE	LTL
N	BLOCK, PUR #931	4/5/18
O	622-064 WAS 622-050, ADD	LTL
P	624-008-1, & 624-008-2	8/29/18
Q	WAS 610-002, 610-007, 610-008-1, & -2, PUR #995	8/29/18
R	ADD STICKER P-192, PUR LTL	2/9/17
S	#638	2/9/17

NOTE:

- QTY LISTED FOR ITEMS 3, 4 & 5 ARE STANDARD. ACTUAL QTY MAY VARY WITH ROPE DIAMETER.
- REFERENCE DIMENSIONS SHOWN TO AID IN SETUP AND INSTALL

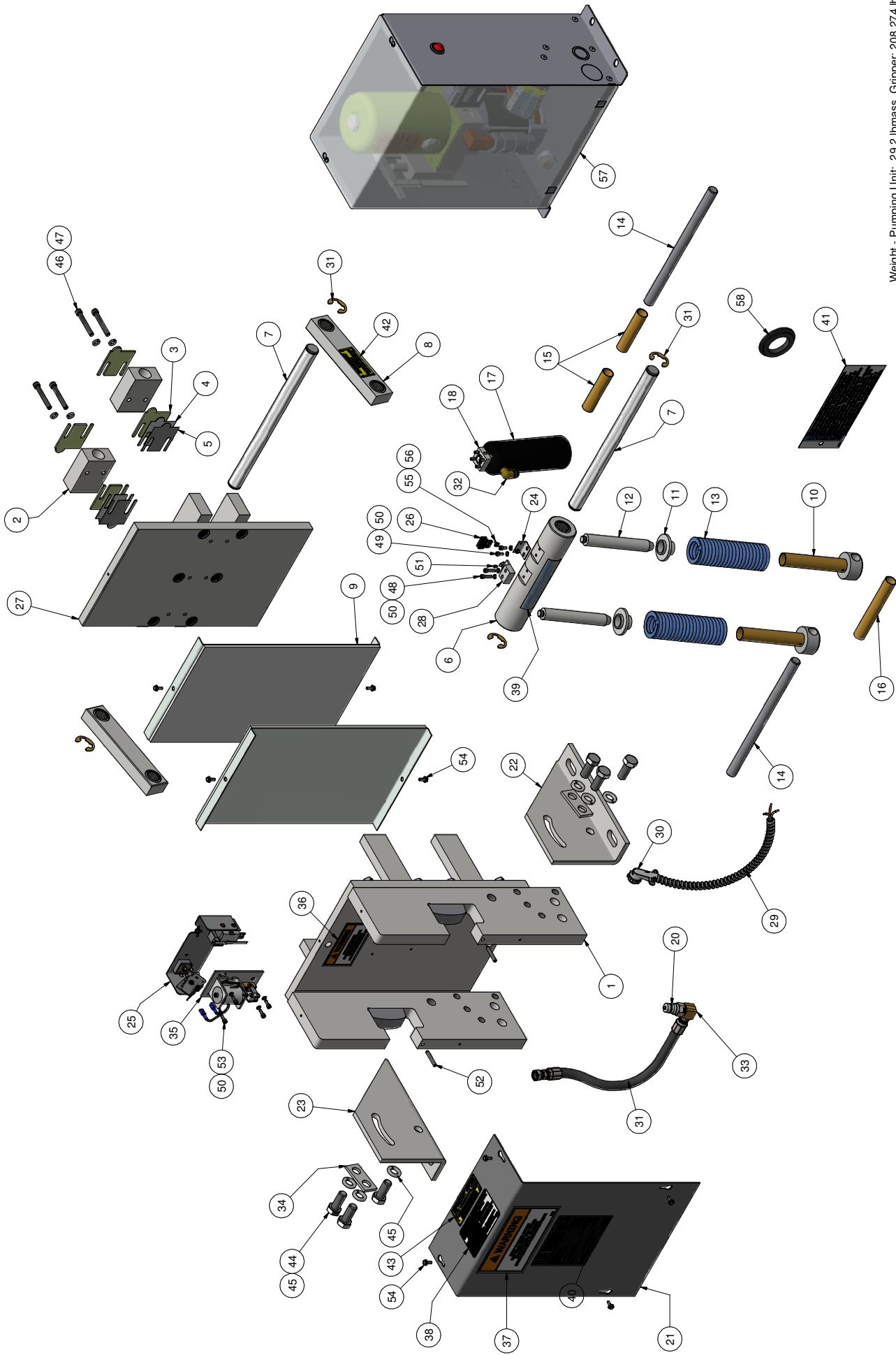

Weight - Pumping Unit: 29.2 lbmass, Gripper: 208.274 lbmass

HOLLISTER-WHITNEY	
ELEVATOR CO., LLC	
TITLE	
ROPE GRIPPER ASSEMBLY	
DRAWN	SCALE
BY	MATERIAL
LTL	1/5
SEE PARTS LIST	REFERENCE TOL. UNLESS OTHERWISE SPECIFIED
SHEET SIZE	DATE
C	10/12/2006
	624
	SHEET 2 OF 2

SEE PREVIOUS PAGE FOR REVISIONS

ITEM	QTY	PART NUMBER	DESCRIPTION
1	1	625-003	STATIONARY SHOE ASSEMBLY
2	2	624-007	SHAFT SUPPORT BLOCK
3	4	624-008	SPACER (11 GA.) - LINING WEAR
4	2	624-008-1	SPACER (16 GA.) - LINING WEAR
5	2	624-008-2	SPACER (22 GA.) - LINING WEAR
6	1	625-015	TUBING ASSEMBLY
7	2	610-018	SHAFT - ROTATING & NON-ROTATING
8	2	610-020	CONNECTING ARM ASSEMBLY
9	2	625-022	LINING ASSEMBLY
10	2	600-025	LOWER SPRING GUIDE ASSEMBLY
11	2	600-027	UPPER SUPPORT - SPRING
12	2	600-029	GUIDE - UPPER SPRING SUPPORT
13	2	600-030	SPRING
14	2	610-031	SHAFT
15	2	605-032	TUBING - SPACER
16	1	605-033	TUBING - SPACER
17	1	600-035	CYLINDER ASSEMBLY
18	1	622-036	HYDRAULIC CYLINDER PIVOT BRACKET ASSEMBLY
19	1	620-037	HOSE - VARIOUS LENGTHS
20	1	620-038	QUICK CONNECT FITTING
21	1	625-040	COVER - 625 ROPE GRIPPER
22	1	610-041 R	ANGLE R.H. - MOUNTING
23	1	610-041 L	ANGLE L.H. - MOUNTING
24	1	600-051	ACTUATING ANGLE w/SCREWS
25	1	618-067	CONTACT PLATE ASSEMBLY
26	1	622-064	SWITCH ASSY (LEAD LENGTHS, -1 = 10', -2 = 24', -3 = 18')
27	1	625-072	MOVABLE SHOE ASSEMBLY
28	1	601-078	LATCH
29	1	600-081	CONDUIT - FLEXIBLE (1/2")
30	1	600-082	801-DC2 90° ANGLE BOX CONNECTOR
31	4	610-085	E-CLIP (TRUARC) X5133-98
32	1	610-087	PARKER #149F-6 4 MALE ELBOW
33	1	610-091	3-8 x 3-8 NPT STREET 90 DEG. ELBOW
34	2	610-095	WASHER - DOUBLE BOLT
35	1	620-607	SOLENOID LOCKING UNIT
36	1	P-133	ROPE GRIPPER WARNING LABEL - MEDIUM
37	2	P-134	ROPE GRIPPER WARNING LABEL - LARGE
38	1	P-137	GRIPPER LUBE INST. STICKER
39	1	P-141	IMPORTANT LABEL - APPLIED TO TUBING
40	1	P-144-2	AIR BLEED LABEL
41	1	P-145	625 ROPE GRIPPER LABEL
42	2	P-186	ROPE GRIPPER WEAR-IN LINE STICKER
43	1	P-192	IMPORTANT NOTICE - LANG LAY ROPES, ROPE GRIPPER
44	6	5/8" - 11 UNC x 1.5"	HEX HEAD CAP SCREW
45	6	5/8 WASHER	STANDARD LOCK
46	4	5/16 - 18 UNC x 2.25	SOCKET HEAD CAP SCREW
47	4	5/16 WASHER	STANDARD LOCK
48	2	1/4 - 20 UNC x 1.5	HALF DOG SET SCREW
49	2	#10-32 UNF x 0.75	SOCKET HEAD CAP SCREW
50	2	#10-32 UNF x 0.375"	SOCKET HEAD CAP SCREW
51	8	#10 LOCK WASHER	STANDARD LOCK WASHER
52	1	10-32 UNF x 0.25	SET SCREW
53	4	#10-24 UNC x 0.5	SOCKET HEAD CAP SCREW
54	8	#10-24 UNC x 0.5	WHIZ BOLT
55	1	#6-32 UNCX0.3125	BRASS MACHINE SCREW
56	1	#6 WASHER	STANDARD WASHER
57	1	620-100	PUMPING UNIT
58	1	622-207	HOSE GROMMET

F	ADD PAD POSITION REF. LTL	10/7/16	HOLLISTER-WHITNEY
	ADD PUR #798	11/15/13	ELEVATOR CO. LLC
	CONT. PUR CORRECTED, PUR #622	BLG	
	REDRAW, PUR #584	BOM	ROPE GRIPPER ASSEMBLY
	REVISED PART NUMBERS, PUR #426	8/24/10	DRAWN SCALE MATERIAL
	PUR #383	1/15/09	BY
	PUR #359	1/2/07	SEE PARTS LIST
		C	DATE
			SHEET SIZE
			625
			1/24/2007
			SHEET 1 OF 2

K	620-607 WAS FIG 0003N, CAPTURE GROMMET & P-144-2, PUR #688	LTL	5/22/18
		J	4/5/18
	UPDATE P-192, TITLE BLOCK, PUR #831	H	8/29/18
	625-072, 624-007, 624-008, 624-008-1, & 624-008-2 WAS 625-002, 610-007, 610-008-.1, & -2, PUR #999	G	8/29/18
			2/9/17

L	625-072, 624-007, 624-008, 624-008-1, & 624-008-2 WAS 625-002, 610-007, 610-008-.1, & -2, PUR #999	LTL	8/29/18
			2/9/17

NOTE:
 1. QTY LISTED FOR ITEMS 3, 4 & 5 ARE STANDARD. ACTUAL QTY MAY VARY WITH ROPE DIAMETER.
 2. REFERENCE DIMENSIONS SHOWN TO AID IN SETUP AND INSTALL

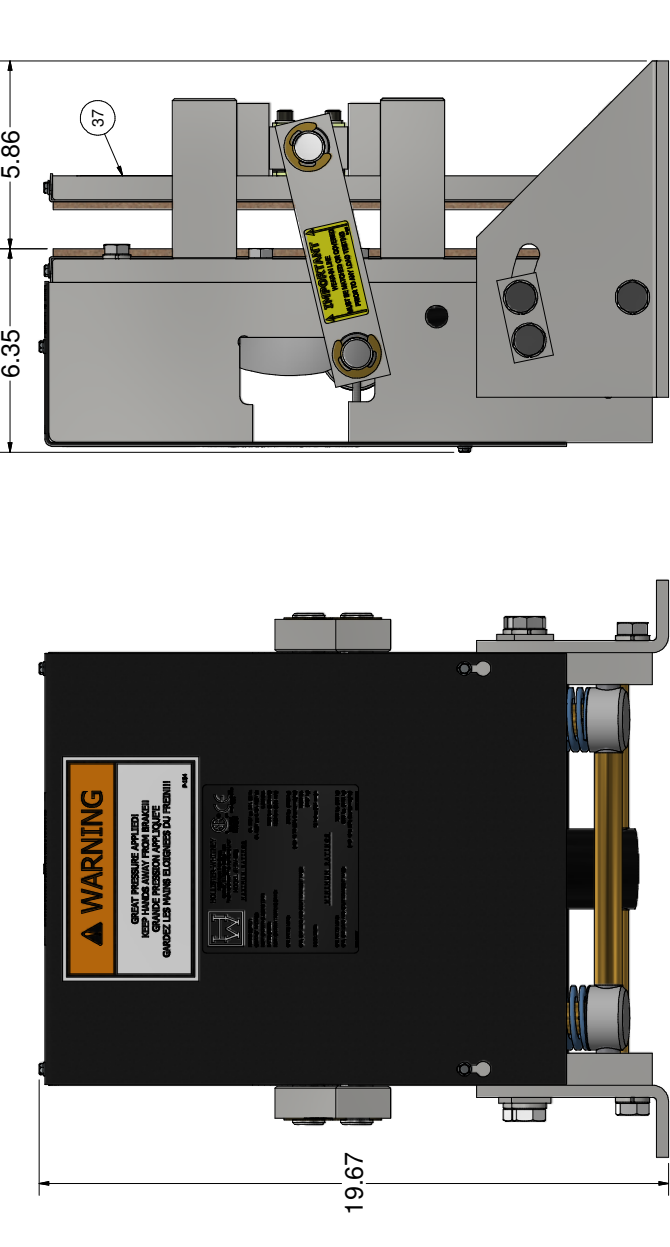
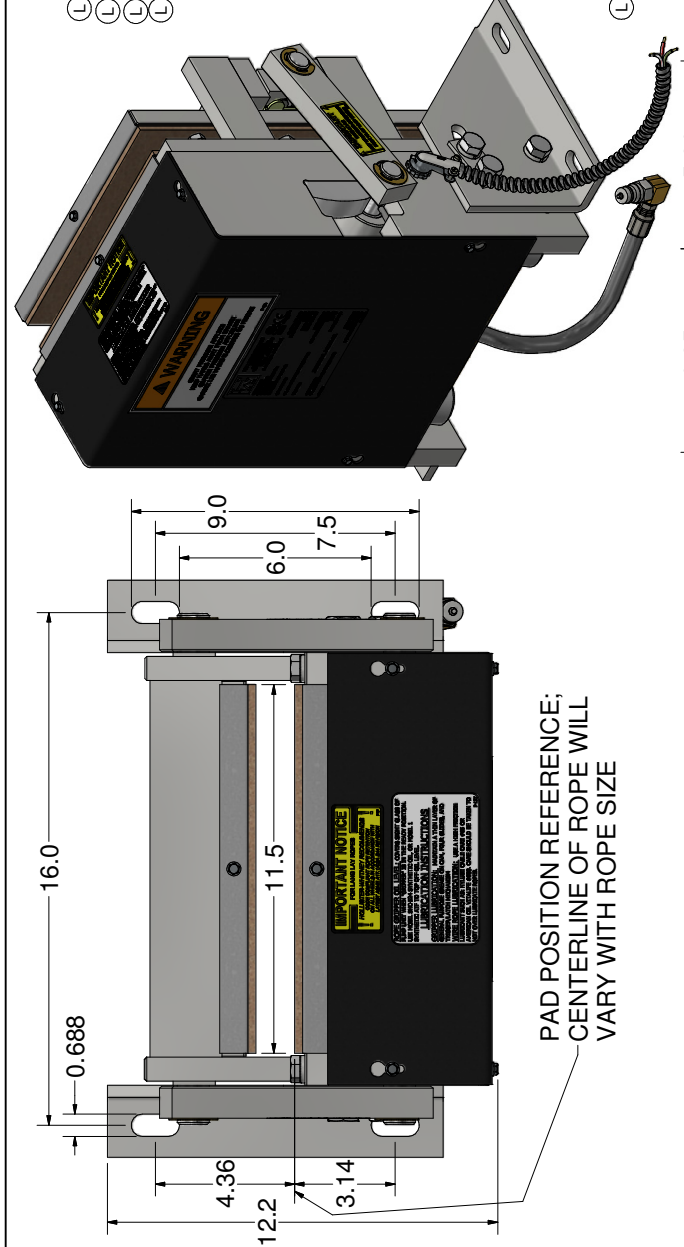

PAD POSITION REFERENCE;
 CENTERLINE OF ROPE WILL
 VARY WITH ROPE SIZE

Weight - Pumping Unit: 29.2 lbmass, Gripper: 225.275 lbmass

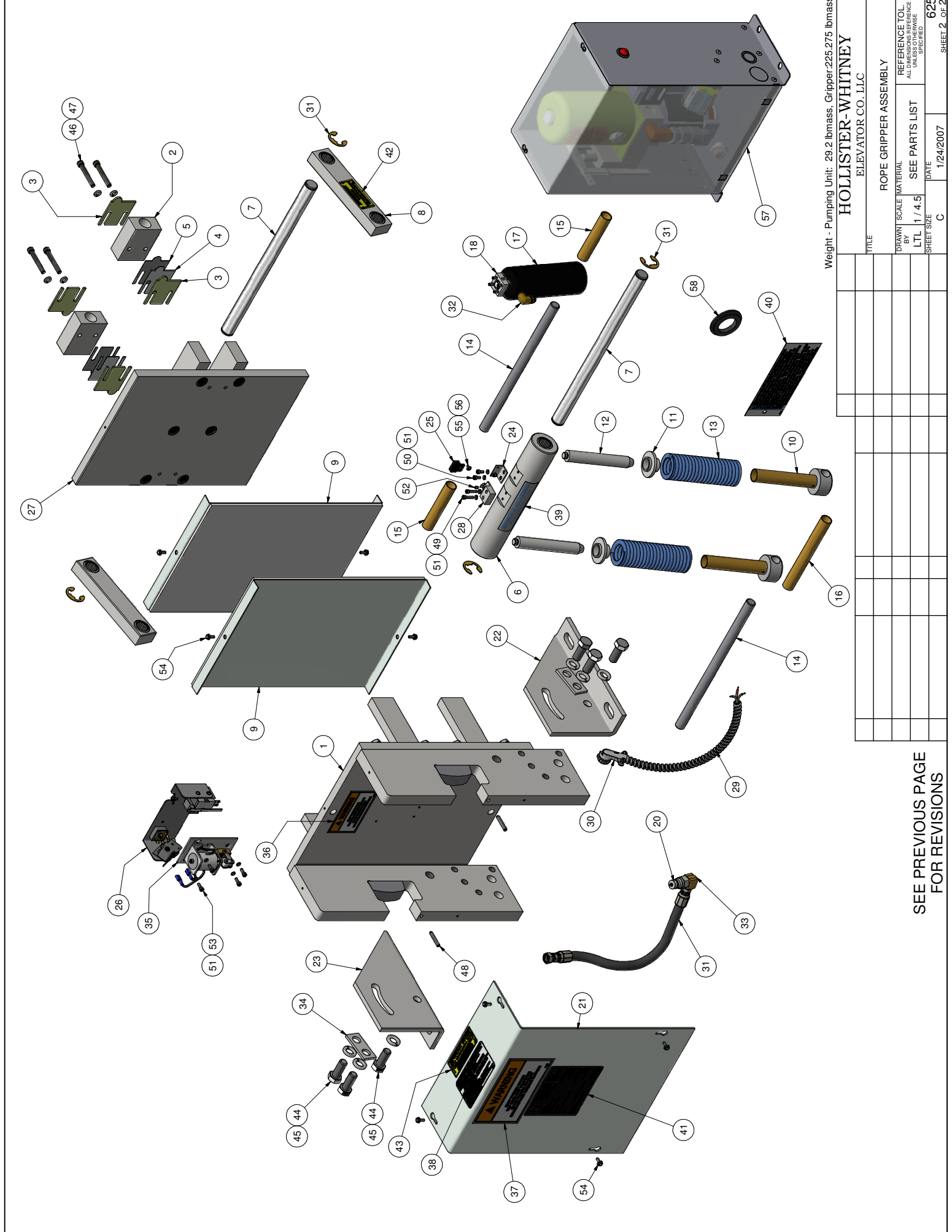

Weight - Pumping Unit: 29.2 lbmass, Gripper:225.275 lbmass

TITLE	
ELEVATOR CO. LLC	
ROPE GRIPPER ASSEMBLY	
DRAWN SCALE	REFERENCE TOL.
BY LTL 1 / 4.5	ALL UNLESS OTHERWISE SPECIFIED
SEE PARTS LIST	DATE
SHEET SIZE C	1/24/2007
	625
	SHEET 2 OF 2

SEE PREVIOUS PAGE FOR REVISIONS

PARTS LIST

ITEM	QTY	PART NUMBER	DESCRIPTION
1	2	626-003	STATIONARY SHOE ASSEMBLY
2	1	624-007	SHAFT SUPPORT BLOCK
3	1	626-007	SHAFT SUPPORT BLOCK
4	6	624-008	SPACER (11 GA.) - LINING WEAR
5	3	624-008-1	SPACER (16 GA.) - LINING WEAR
6	3	624-008-2	SPACER (22 GA.) - LINING WEAR
7	1	626-015	TUBING ASSEMBLY
8	2	626-018	SHAFT - ROTATING & NON-ROTATING
9	2	610-020	CONNECTING ARM ASSEMBLY
10	2	610-022	LINING ASSEMBLY
11	3	600-025	LOWER SPRING GUIDE ASSEMBLY
12	3	600-027	UPPER SUPPORT - SPRING
13	3	600-029	GUIDE - UPPER SPRING SUPPORT
14	3	600-030	SPRING
15	2	626-031	SHAFT
16	3	626-032	TUBING - SPACER
17	2	626-033	TUBING - SPACER
18	2	610-035	610-035 CYLINDER ASSEMBLY
19	2	622-036	HYDRAULIC CYLINDER PIVOT BRACKET ASSEMBLY
20	1	620-037	HOSE ASSEMBLY VARIOUS LENGTHS
21	1	620-038	QUICK CONNECT FITTING
22	1	626-040	COVER - 624 & 626 ROPE GRIPPER
23	1	610-041 R	ANGLE, R.H. - MOUNTING
24	1	610-041 L	ANGLE, L.H. - MOUNTING
25	1	600-051	ACTUATING ANGLE w/SCREWS
26	1	622-064	SWITCH ASSY (LEAD LENGTHS, -1 = 10', -2 = 24', -3 = 18')
27	1	618-067	CONTACT PLATE ASSEMBLY
28	1	624-072	MOVABLE SHOE ASSEMBLY
29	1	601-078	LATCH
30	1	600-081	CONDUIT - FLEXIBLE (1/2")
31	1	600-082	801-DC2 90° ANGLE BOX CONNECTOR
32	4	610-085	E-CLIP (TRUARC) X5133-98
33	1	610-086	3/8" TEE
34	2	610-087	PARKER #149F-6-4 MALE ELBOW
35	1	610-088	BRASS ELBOW, #149F-6-6, 45° FH 5/8"-18 x 3/8 NPTF-18
36	1	610-091	3-8 x 3-8 NPT STREET 90 DEG. ELBOW
37	2	626-092	HOSE ASSEMBLY
38	2	610-095	WASHER - DOUBLE BOLT
39	1	620-607	SOLENOID LOCKING UNIT
40	1	P-133	ROPE GRIPPER WARNING LABEL - MEDIUM
41	2	P-134	ROPE GRIPPER WARNING LABEL - LARGE
42	1	P-137	GRIPPER LUBE INST. STICKER
43	1	P-140	626 & 626SPL ROPE GRIPPER LABEL
44	1	P-141	IMPORTANT LABEL - APPLIED TO TUBING
45	1	P-144-2	AIR BLEED LABEL
46	2	P-186	ROPE GRIPPER WEAR-IN LINE STICKER
47	1	P-192	IMPORTANT NOTICE - LANG LAY ROPES, ROPE GRIPPER
48	6	5/8-11 UNC x 2	HEX HEAD CAP SCREW
49	6	5/8 WASHER	STANDARD LOCK
50	6	5/16 - 18 UNC x 2.25	SOCKET HEAD CAP SCREW
51	6	5/16 WASHER	STANDARD LOCK
52	2	1/4 - 20 UNC x 1.5	HALF DOG SET SCREW
53	2	#10-32 UNF x 0.75	SOCKET HEAD CAP SCREW
54	2	#10-32 UNF x 0.375"	SOCKET HEAD CAP SCREW
55	8	#10 LOCK WASHER	STANDARD LOCK WASHER
56	1	10-32 UNF x 0.25	SET SCREW
57	4	#10-24 UNC x 0.5	SOCKET HEAD CAP SCREW
58	8	#10-24 UNC x 0.5	WHIZ BOLT
59	1	#6-32 UNC X 0.3125	BRASS MACHINE SCREW
60	1	#6 WASHER	STANDARD WASHER
61	1	620-100	PUMPING UNIT
62	1	622-207	HOSE GROMMET

NOTE:

- QTY LISTED FOR ITEMS 4, 5, & 6 ARE STANDARD. ACTUAL QTY MAY VARY WITH ROPE DIAMETER.
- REFERENCE DIMENSIONS SHOWN TO AID IN SETUP AND INSTALL

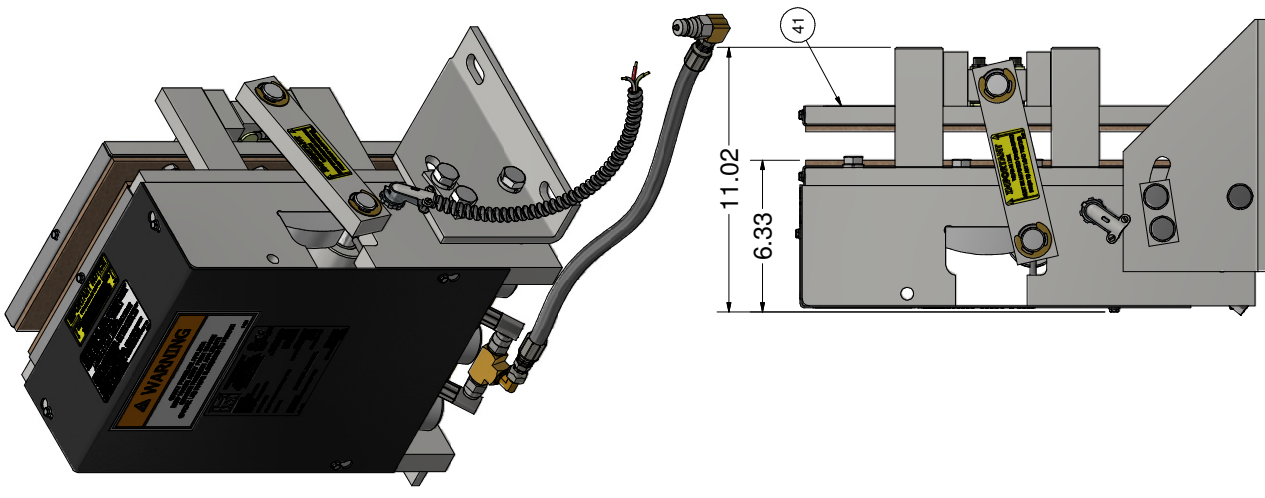

PAD POSITION REFERENCE;
CENTERLINE OF ROPE WILL
VARY WITH ROPE SIZE

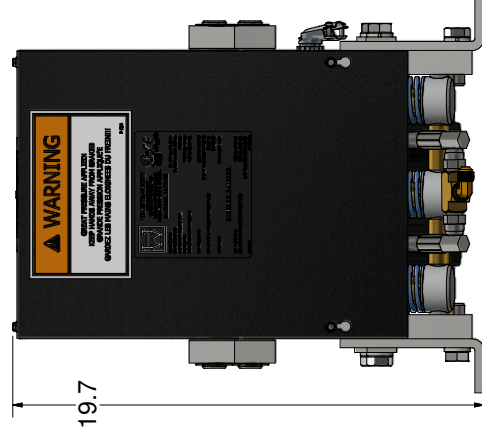

Weight - Pumping Unit: 29.2 lbmass, Gripper: 213.719 lbmass	
HOLLISTER-WHITNEY ELEVATOR CO. LLC	
ROPE GRIPPER ASSEMBLY	
DRAWING SCALE MATERIAL	
BY	DATE
LTL 1/4	5/27/06
SEE PARTS LIST	6/25/03
DATE	5/27/2004
SHEET SIZE	C
SHEET 1 OF 2	626

REV	DESCRIPTION	DATE	BY	CHKD
F	CYL PIN CORRECTED TO LTL	5/22/18	L	L
E	610-035, PUR #626, PUR #626 CORRECTED, PUR #626 CORRECTED	4/5/18	L	L
D	REDRAW, PUR #594	4/13/17	L	L
C	REVISED PART	2/9/17	L	L
B	NUMBERS, PUR #426	12/8/16	L	L
A	PUR #349	10/7/16	L	L
M	15144-2, 10-32, 7/8 WAS	5/22/18	L	L
L	10-32 X 0.75, PUR #666	5/22/18	L	L
K	620-067 & P-186, PUR #655	4/13/17	L	L
J	620-067 & P-186, PUR #655	4/13/17	L	L
H	610-002, 610-008, -1, 8/29/18	12/8/16	L	L
G	626-007 WAS 3k, 610-007, #699	12/8/16	L	L
F	620-607 WAS RG-0003N, LTL	10/7/16	L	L

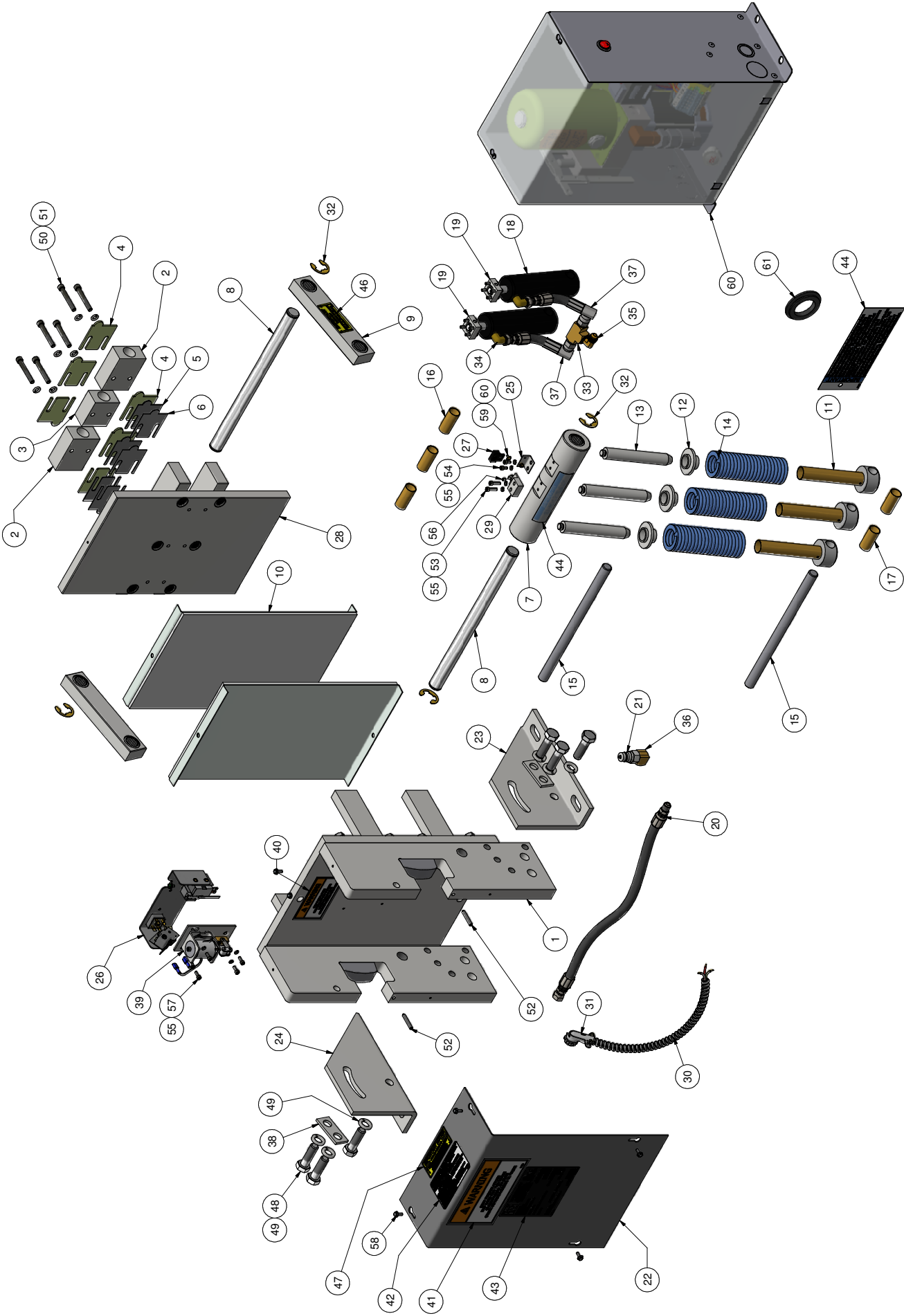

Weight - Pumping Unit: 29.2 lbmass, Gripper: 2.13.719 lbmass

HOLLISTER-WHITNEY	
ELEVATOR CO., LLC	
TITLE	
ROPE GRIPPER ASSEMBLY	
DRAWN	SCALE
BY	MATERIAL
LTL	1 / 5
SEE PARTS LIST	REFERENCE TOL.
DATE	UNLESS OTHERWISE SPECIFIED
5/27/2004	626
SHEET SIZE	C
SHEET 2 OF 2	

SEE PREVIOUS PAGE FOR REVISIONS

PARTS LIST

ITEM	QTY	PART NUMBER	DESCRIPTION
1	1	626-003-SPL	STATIONARY SHOE ASSEMBLY
2	2	624-007	SHAFT SUPPORT BLOCK
3	1	626-007	SHAFT SUPPORT BLOCK
4	6	624-008	SPACER (11 GA.) - LINING WEAR
5	3	624-008-1	SPACER (16 GA.) - LINING WEAR
6	3	624-008-2	SPACER (22 GA.) - LINING WEAR
7	1	626-015-SPL	TUBING ASSEMBLY
8	2	626-018-SPL	SHAFT - ROTATING & NON-ROTATING
9	2	610-020	CONNECTING ARM ASSEMBLY
10	2	610-022-SPL	LINING ASSEMBLY
11	3	600-025	LOWER SPRING GUIDE ASSEMBLY
12	3	600-027	UPPER SPRING GUIDE - SPRING
13	3	600-029	GUIDE - UPPER SPRING SUPPORT
14	3	600-030	SPRING
15	2	626-031-SPL	SHAFT
16	2	601-032	TUBING - SPACER
17	1	626-032-SPL	TUBING - SPACER
18	2	626-033-SPL	TUBING - SPACER
19	2	610-035	610-035 CYLINDER ASSEMBLY
20	2	622-036	HYDRAULIC CYLINDER PIVOT BRACKET ASSEMBLY
21	1	620-037	HOSE ASSEMBLY VARIOUS LENGTHS
22	1	620-038	QUICK CONNECT FITTING
23	1	626-040-SPL	COVER - ROPE GRIPPER
24	1	610-041 R	ANGLE, R.H. - MOUNTING
25	1	610-041 L	ANGLE, L.H. - MOUNTING
26	1	600-051	ACTUATING ANGLE w/SCREWS
27	1	622-064	SWITCH ASSY (LEAD LENGTHS, -1 = 10', -2 = 24', -3 = 18')
28	1	618-067	CONTACT PLATE ASSEMBLY
29	1	626-072-SPL	MOVABLE SHOE ASSEMBLY
30	1	601-078	LATCH
31	1	600-081	CONDUIT - FLEXIBLE (1/2")
32	1	600-082	801-DC2 90° ANGLE BOX CONNECTOR
33	4	610-085	E-CLIP (TRUARC) X5133-98
34	1	610-086	3/8 NPT TEE
35	2	610-087	PARKER #149F-6.4 MALE ELBOW
36	1	610-088	BRASS ELBOW, #149F-6-6, 45° FH 5/8" - 18 x 3/8 NPT F18
37	2	626-092	HOSE ASSEMBLY
38	1	610-091	3-8 x 3-8 NPT STREET 90 DEG. ELBOW
39	2	610-095	WASHER - DOUBLE BOLT
40	1	626-097-SPL	BAR - SUPPORT
41	2	622-115	3/8 NPT EXTENSION
42	1	620-607	SOLENOID LOCKING UNIT
43	2	P-134	ROPE GRIPPER WARNING LABEL - LARGE
44	1	P-137	GRIPPER LUBE INST. STICKER
45	1	P-140	626 & 626SPL ROPE GRIPPER LABEL
46	1	P-141	IMPORTANT LABEL - APPLIED TO TUBING
47	1	P-144-2	AIR BLEED LABEL
48	2	P-186	ROPE GRIPPER WEAR-IN LINE STICKER
49	1	P-192	IMPORTANT NOTICE - LANG LAY ROPES, ROPE GRIPPER
50	6	5/8 - 11 UNC x 2	HEX HEAD CAP SCREW
51	6	5/8 WASHER	STANDARD LOCK
52	2	1/2 - 13 UNC x 1.75"	HEX HEAD CAP SCREW
53	2	1/2" WASHER	STANDARD WASHER
54	6	5/16-18 UNC x 1.75	SOCKET HEAD CAP SCREW
55	6	5/16 WASHER	STANDARD LOCK
56	2	1/4 - 20 UNC x 1.5	HALF DOG SET SCREW
57	2	#10-32 UNF x 0.75	SOCKET HEAD CAP SCREW
58	2	#10-32 UNF x 0.375"	SOCKET HEAD CAP SCREW
59	1	10-32 UNF x 0.25	SET SCREW
60	4	5/16-18 UNC x 1.75	SOCKET HEAD CAP SCREW
61	8	#10-24 UNC x 0.5	WHIZ BOLT
62	8	#10 LOCK WASHER	STANDARD LOCK WASHER
63	1	#6-32 UNCX0.3125	BRASS MACHINE SCREW
64	1	#6 WASHER	STANDARD WASHER
65	1	620-100	PUMPING UNIT
66	1	622-207	HOSE GROMMET

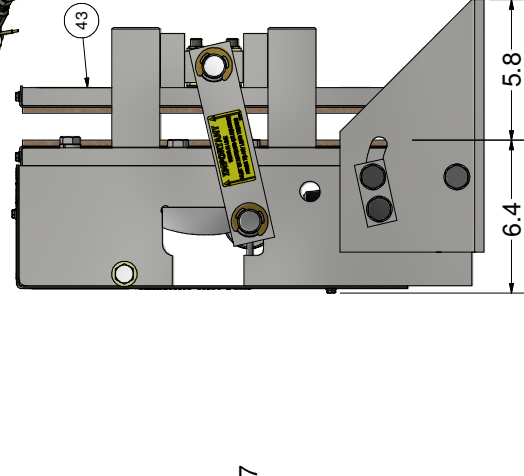
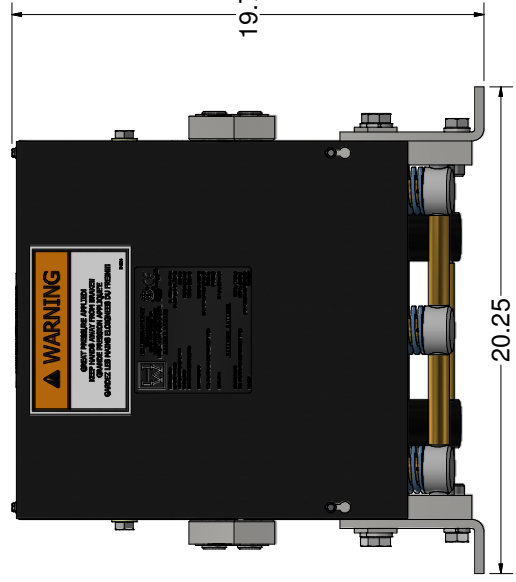
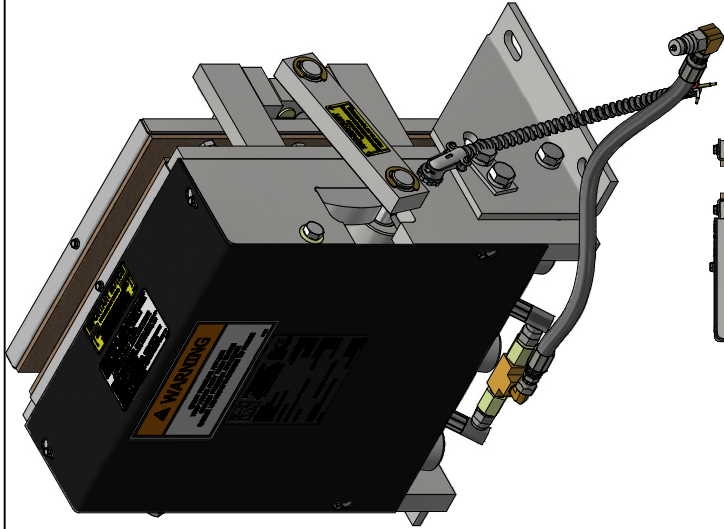
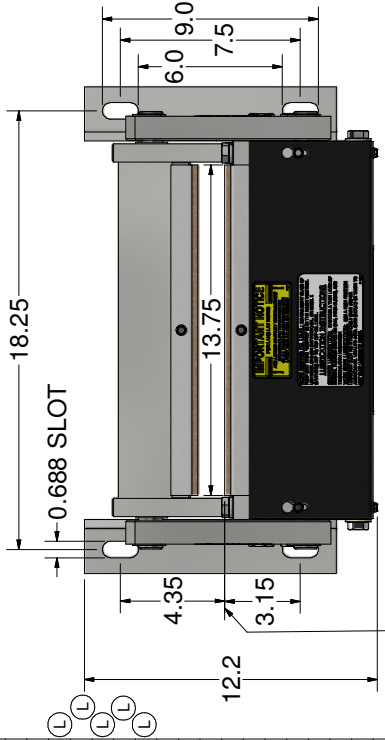

NOTE:
 1. QTY LISTED FOR ITEMS 4, 5, & 6 ARE STANDARD. ACTUAL QTY MAY VARY WITH ROPE DIAMETER.
 2. REFERENCE DIMENSIONS SHOWN TO AID IN SETUP AND INSTALL

Weight - Pumping Unit: 29.2 lbmass, Gripper: 258.324 lbmass	
HOLLISTER-WHITNEY	
ELEVATOR CO. LLC	
ROPE GRIPPER ASSEMBLY	
DRAWING SCALE MATERIAL	
BY BLG 1 / 4	
SEE PARTS LIST	
REFERENCE TO: ALL UNLESS OTHERWISE SPECIFIED	
626-SPL	
SHEET 1 OF 2	

REV	DESCRIPTION	DATE	BY	CHKD	APP'D
F	610-087 CORRECTED TO LTL ADD P-192 PUR #615	12/8/16			
E	ADD P-192 PUR #615	10/7/16			
D	COIL PIN CORRECTED, LTL PUR #622	11/5/13			
C	REDRAW, PUR # 594	6/3/13			
B	REVISED PART NUMBERS, PUR # 426	8/24/10			
A	ADD STICKER P-192, PUR # 426	1/2/07			

K	620-607 WAS FIC-0003N, CAPTURE GROMMET & P-144-2, 10-32 x 7/8 WAS	5/22/18	LTL		
J	UPDATE P-192, TITLE BLOCK, PUR #831	4/5/18	LTL		
H	622-064 WAS 622-050, ADD 620-067 & P-186, PUR #855	5/17/17	LTL		
G	ADD STICKER P-192, PUR #838	2/9/17	LTL		

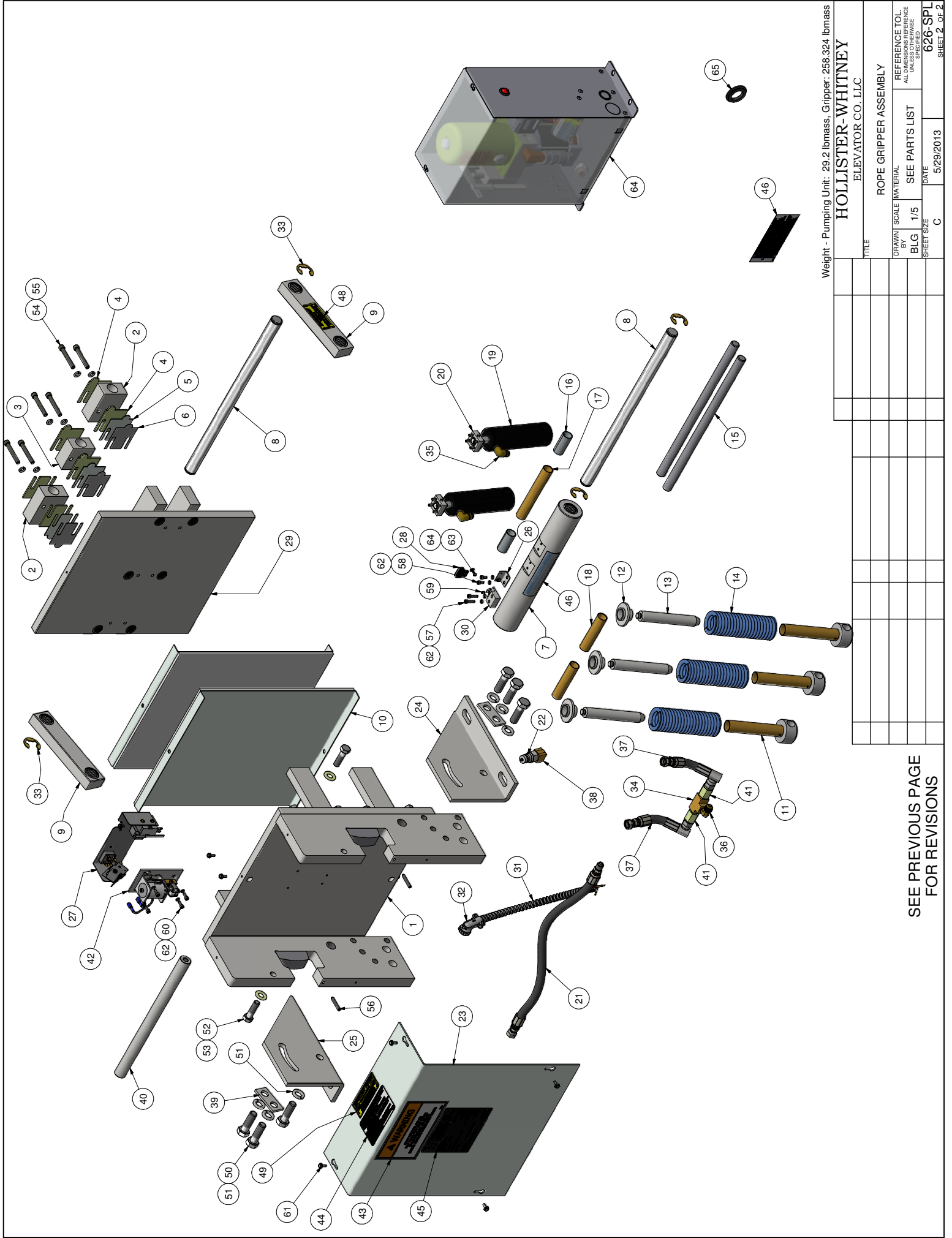

Weight - Pumping Unit: 29.2 lbmass, Gripper: 258.324 lbmass

HOLLISTER-WHITNEY	
ELEVATOR CO., LLC	
TITLE	
ROPE GRIPPER ASSEMBLY	
DRAWN	SCALE
BY	MATERIAL
BLG	1/5
SEE PARTS LIST	REFERENCE TOL. UNLESS OTHERWISE SPECIFIED
SHEET SIZE	DATE
C	5/29/2013
626-SPL	SHEET 2 OF 2

SEE PREVIOUS PAGE FOR REVISIONS

PARTS LIST

ITEM QTY	PART NUMBER	DESCRIPTION
1	620-600	BOX ASSEMBLY, 620 PUMPING STATION
2	620-205	VALVE, EATON VICKERS SV-10-OP-0 W/O NUT
3	622-206	PUMPING UNIT DUMP VALVE COIL
4	620-620	12" WIRE, 18AWG STRANDED, RED W/F. SHIELDED CONNECTOR
5	620-621	9" WIRE, 18AWG STRANDED, YELLOW
6	620-622	4" WIRE, 18AWG STRANDED, BLUE W/F. SHIELDED CONNECTORS
7	620-623	7" WIRE, 18AWG STRANDED, BLUE W/F. SHIELDED CONNECTOR
8	620-624	LOCKING HOLE PLUG
9	620-625	CAPACITOR MOUNTING BRACKET
10	201-032	LOCKING HOLE PLUG
12	1/2-20 NUT	1/2-20 UNF HEX NUT
13	#10-32 UNF x 0.375"	WHIZ BOLT
14	#10 WASHER	EXTERNAL TOOTH LOCK WASHER
15	#8 - 32 UNC x 2.375"	ROUND HEAD MACHINE SCREW
16	#8 - 32 UNC x 1/4"	ROUND HEAD MACHINE SCREW
17	#6-32 UNC X 1"	BRASS MACHINE SCREW
18	#6 WASHER	EXTERNAL STAR LOCK WASHER
19	M8 - 1.25 X 12MM	HEX HEAD CAP SCREW
20	8mm WASHER	STANDARD LOCK WASHER
21	CAP-0131N	CAPACITOR, 124-148 uF 250 VAC 50/60 Hz
22	LABEL-0097N	LABEL, 620 ROPE GRIPPER
23	MICS-0016N	SWITCH COVER
24	MICS-0017N	BZ-2RW824-A2 MICROSWITCH
25	RG1-0002N	AUTO/MANUAL MICROSWITCH ASSY
26	RG1-0003N	OIL RESERVOIR BREATHER CAP
27	RG1-0004N	GYG PUMP AND OIL RESERVOIR ASSY
28	RG1-0005N	TERMINAL ASSY, 620 PUMPING STATION
29	RG1-0009N	COVER, 620 ROPE GRIPPER PUMPING STATION
29	SW-0081N	ON-OFF SWITCH, SPST 10A 125V

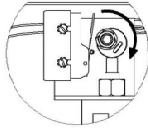

MANUAL MODE: WITH TEST SWITCH
PUMPING UNIT ON. WITH THE
CAM SLOT, THEN SLOWLY ROTATE THE
CAM CLOCKWISE WHILE PUMPING HAND PUMP.

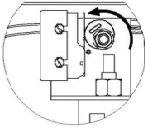

AUTOMATIC MODE: MAKE BAIT HEAD
SCREWDRIVER IN CAM SLOT, THEN FULLY
ROTATE THE CAM COUNTER-CLOCKWISE.
THEN TURN TEST SWITCH ON.

**NOTE: WHEN INSTALLING,
REPLACE SHIPPING CAP ON OIL
RESERVOIR WITH "OIL"
BREATHING CAP (ITEM 25).**

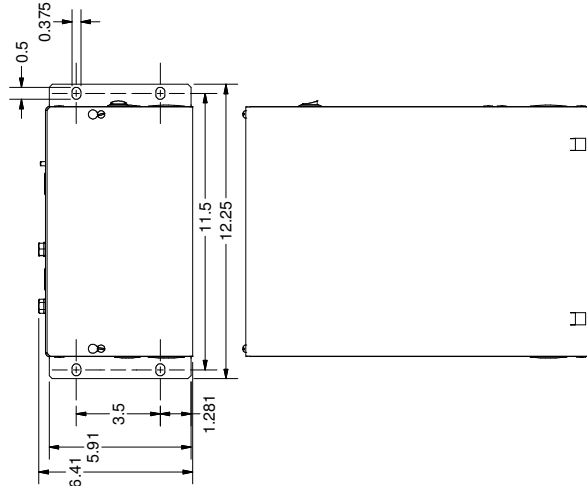
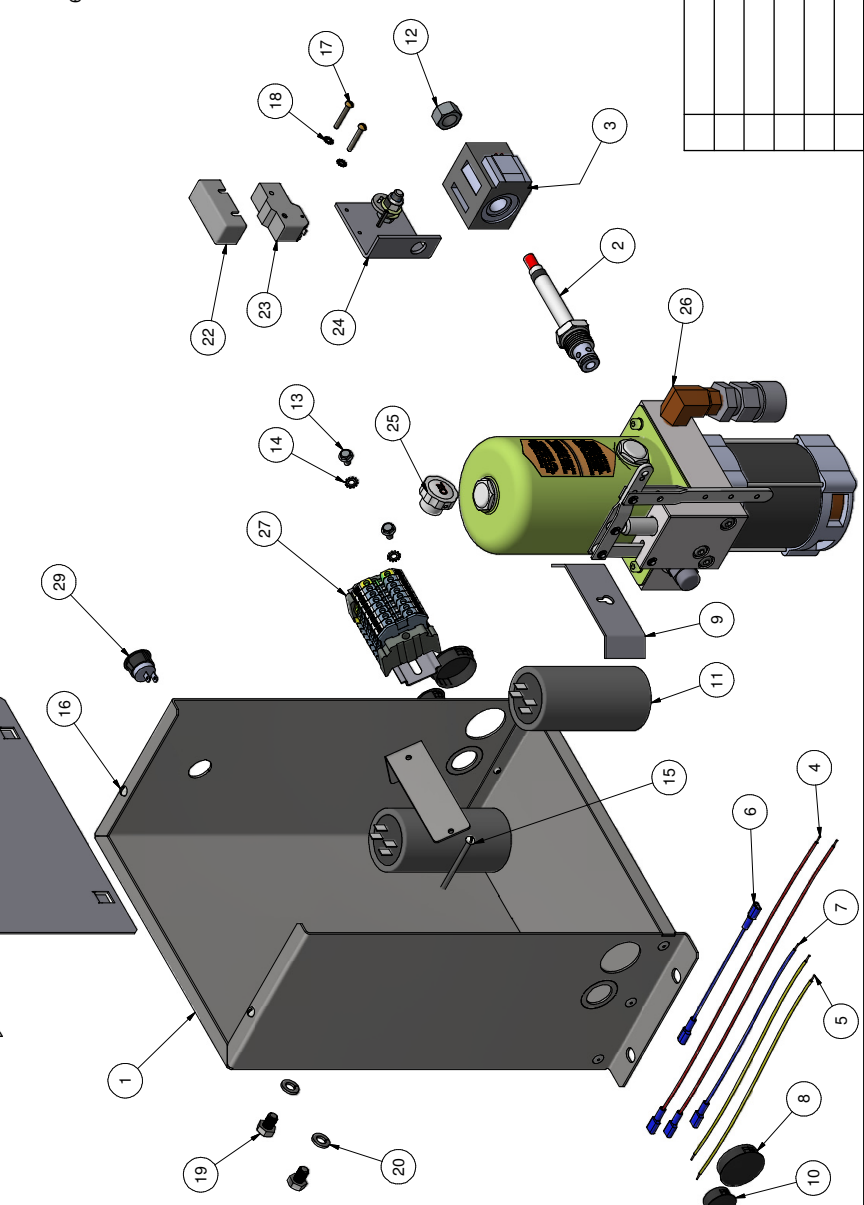
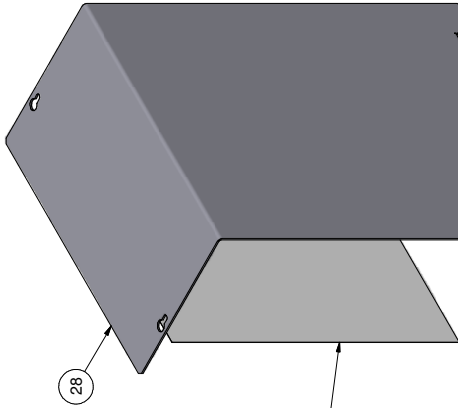
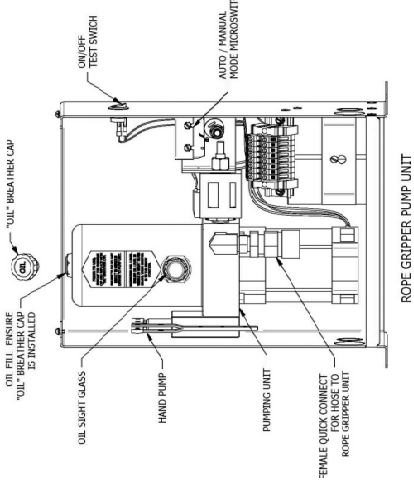

SCALE 1 / 4

(B) SHIPPING WEIGHT: 33 lbs
WEIGHT: 29.2 lbmass

HOLLISTER-WHITNEY ELEVATOR CO. LLC		TITLE	
D	UPDATE PARTS LIST AND TITLES	ADD WIRE PART #23018	
	WASHERS, PUR #98		
C	620-600, 620-205, 622-206	LTL	
	RG-0098N, RG-0087N,	2/23/18	
B	ADD WT. SHIPPING & INSTALLED, PUR #798	LTL	
A	PRODUCTION PRINT,	BLG	
	PUR #602	BLG	
		DATE	4/3/13
		SHEET SIZE	C
		SEE PARTS LIST	
		BY	
		SCALE MATERIAL	
		PUMPING UNIT - 620 THRU 626 ROPE GRIPPER	
		REFERENCE TOL. UNLESS OTHERWISE SPECIFIED.	
		620-100	
		SHEET 1 OF 1	

MICROSWITCH / SOLENOID MOUNTING BRACKET (H.W.620-050)

NOTES	DESCRIPTION	ITEM No.	SPECIFICATIONS	AMOUNT
H.W. 620-050	MICROSWITCH/SOLENOID MT'G. BRACKET	137	# 14 GAUGE C.R.S.	1
	RECTIFIER MOUNTING SCREW	117	6-32 x 5/8 LONG PAN HEAD SCREW	1
	CLAMP MOUNTING SCREW	118	6-32 x 3/8 LONG PAN HEAD SCREW	1
	FEMALE STUD	119	8-32 x 7/16 LONG	1
	CUP WASHER	120	# 8	1
	GROUND SCREW	121	8-32 x 5/16 LONG PAN HEAD SCREW	1
	RECTIFIER DIOD-0015N	122	GI # GBPC 2508	1
	CABLE CLAMP	123	HEYCO 12607	1
	BRASS FLAT WASHERS	124	# 8	2
	NUT	125	8-32 THREAD	2
	MICROSWITCH INSULATOR	126	1/32 FR700 INSULATOR	3
	MICROSWITCH	127	BZ-2RW855-A2-S	3
	MICROSWITCH MOUNTING SCREW	128	6-32 x 5/8 LONG PAN HEAD SCREW	1
	MICROSWITCH MOUNTING SCREW	129	6-32 x 1" LONG PAN HEAD SCREW	1
	MICROSWITCH MOUNTING SCREW	130	6-32 x 1 1/2 LONG ROUND HEAD SCREW	1
	MICROSWITCH MOUNTING SCREW	131	6-32 x 1 3/4 LONG ROUND HEAD CREW	1
	STAR WASHERS	132	# 6	8
	NUT	133	6-32 THREAD	4
CABLE	134	CAROL CABLE 406 # 18-6 CONDUCTOR 45" LONG	1	
NYLON TIE	135	4" LONG	3	

MICROSWITCH / SOLENOID MOUNTING BRACKET (H.W.622-050)

NOTES	DESCRIPTION	ITEM No.	SPECIFICATIONS	AMOUNT
H.W. 622-050	MICROSWITCH/SOLENOID MT'G. BRACKET	136	# 14 GAUGE C.R.S.	1
		117		
		118		
	FEMALE STUD	119	8-32 x 7/16 LONG	1
	CUP WASHER	120	# 8	1
	GROUND SCREW	121	8-32 x 5/16 LONG PAN HEAD SCREW	1
	RECTIFIER DIOD-0015N	122	GI # GBPC 2508	1
	CABLE CLAMP	123	HEYCO 12607	1
	BRASS FLAT WASHERS	124	# 8	2
	NUT	125	8-32 THREAD	2
	MICROSWITCH INSULATOR	126	1/32 FR700 INSULATOR	3
	MICROSWITCH	127	BZ-2RW855-A2-S	3
	MICROSWITCH MOUNTING SCREW	128	6-32 x 5/8 LONG PAN HEAD SCREW	1
	MICROSWITCH MOUNTING SCREW	129	6-32 x 1" LONG PAN HEAD SCREW	1
	MICROSWITCH MOUNTING SCREW	130	6-32 x 1 1/2 LONG ROUND HEAD SCREW	1
	MICROSWITCH MOUNTING SCREW	131	6-32 x 1 3/4 LONG ROUND HEAD CREW	1
	STAR WASHERS	132	# 6	6
	NUT	133	6-32 THREAD	2
CABLE	134	CAROL CABLE 406 # 18-6 CONDUCTOR 45" LONG	1	
NYLON TIE	135	4" LONG	3	

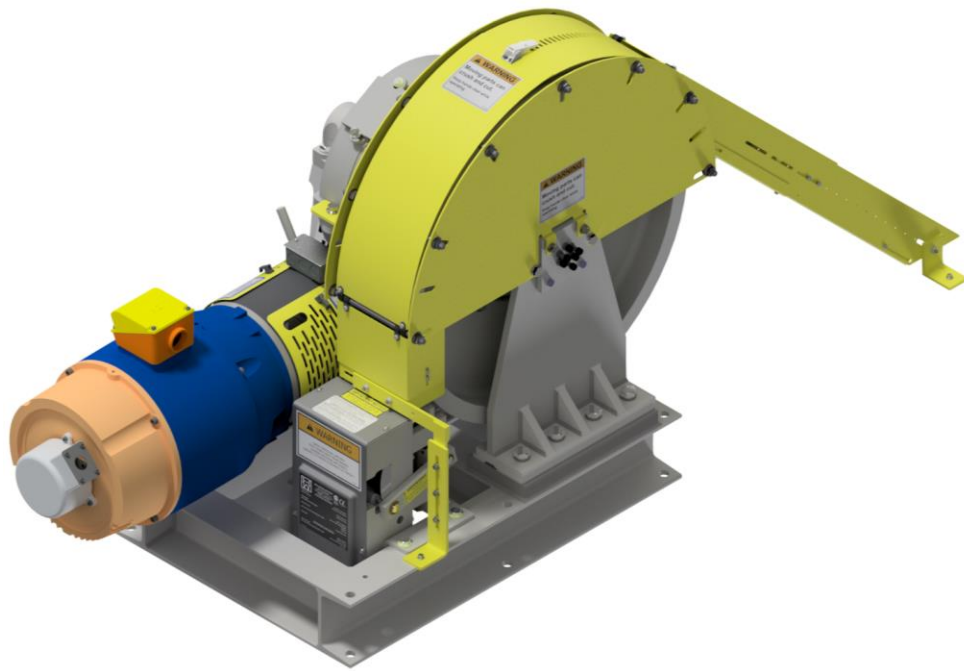

Figure 9: Not To Scale, 44F Machine with Factory Rope Gripper Mount

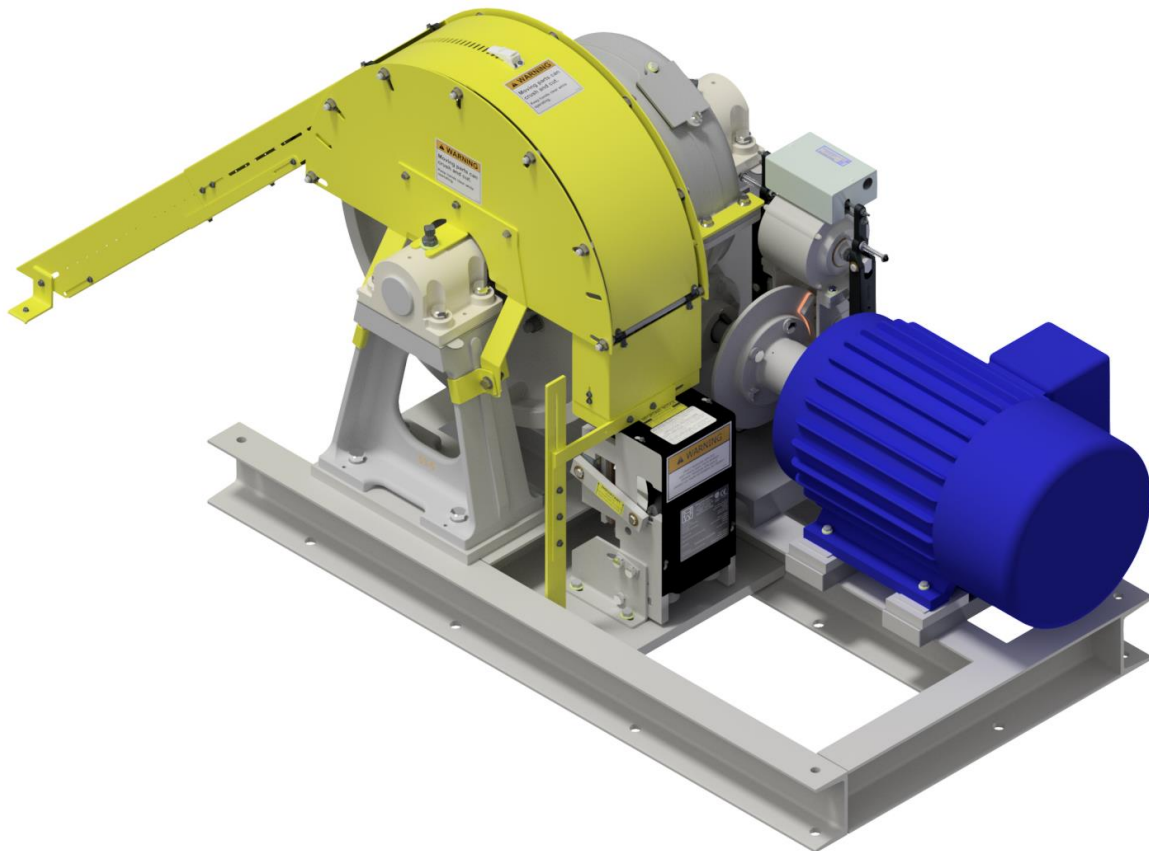

Figure 10: Not To Scale, 54 Machine with Factory Rope Gripper Mount

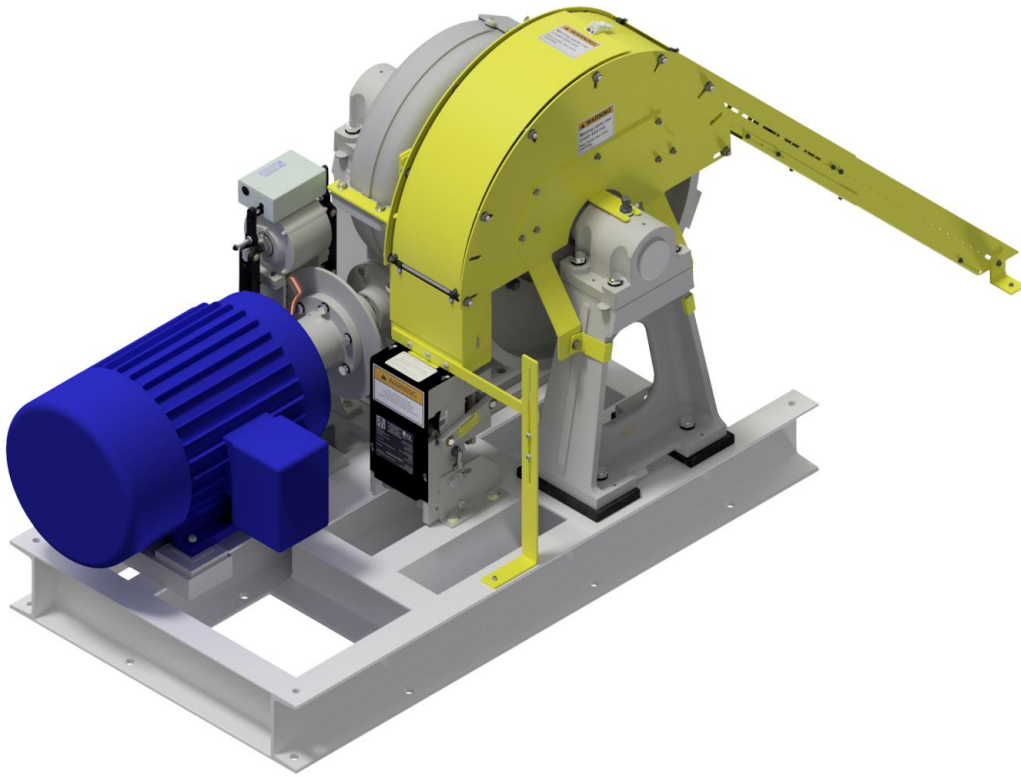

Figure 11: Not To Scale, 64 Machine with Factory Rope Gripper Mount

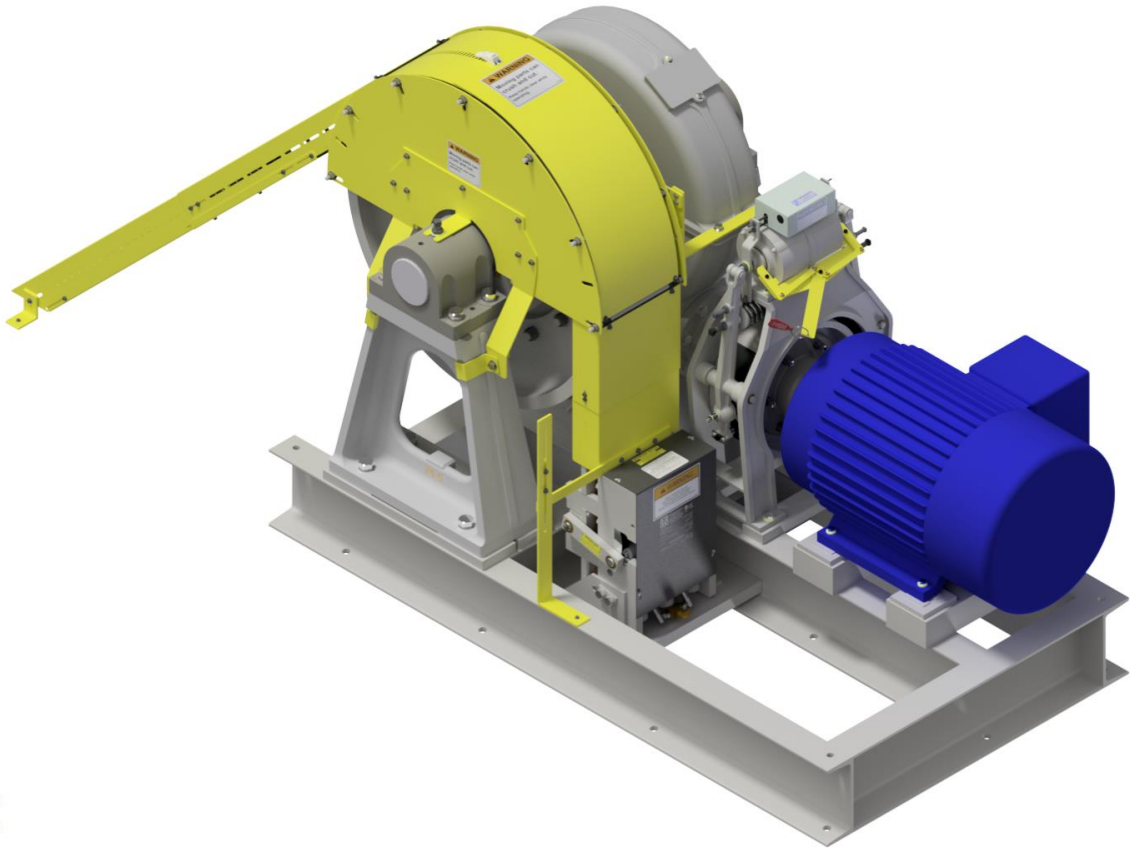

Figure 12: Not To Scale, 74 Machine with Factory Rope Gripper Mount



Commonly Asked Questions:

- Wiring from the gripper to pump unit is color coded per **Chart 2**.
- Connect terminals RG1 and RG2 to elevator control Power Wires
- Connect terminals RG5 and RG7 to elevator control Safety String.
- Check control diagram for proper connection.

White	RG2
Black	RG3
Red	RG4
Orange	RG5
Blue	RG6
Green	Ground

Pigtail to Pumping Unit Wiring Chart 2

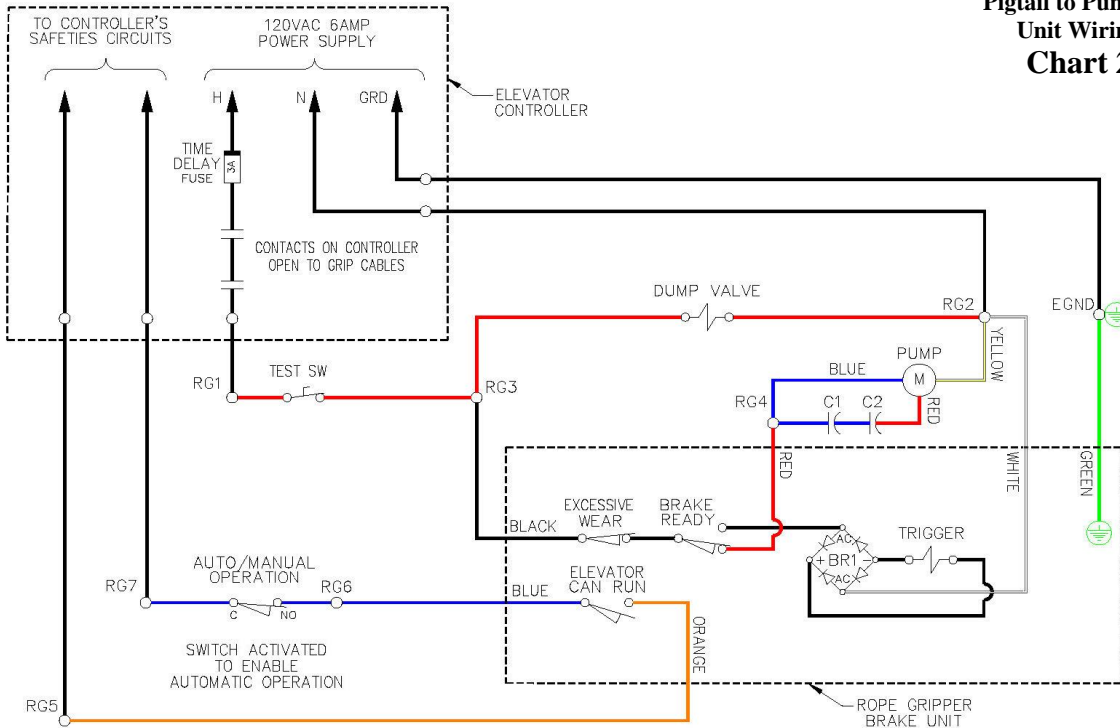

DIAGRAM 4

“ROPE GRIPPER®” Hydraulic Oil

- Check level with the “ROPE GRIPPER®” in the loaded position, the level should fully cover the Oil Level Window on the Oil Reservoir.
- Use **SHC524 Mobil 1 Synthetic Hydraulic Oil** or **Mobil 1 Fully Synthetic ATF (Automatic Transmission Fluid)** to top off oil level.

WIRE ROPE LUBRICATION

- Use a high friction lubricant such as: NYLUBE CABLE CARE #65 or AMERICAN OIL VITALIFE #600. Care should be taken not to over lubricate

Complete Trouble Shooting Guide begins Page 16

For Further Support Contact:

Hollister-Whitney Elevator Co., LLC
 2603 North 24th Street
 Quincy, Illinois 62305
 Phone: 217-222-0466
 Fax: 217-222-0493

<http://www.hollisterwhitney.com/support/>