



Hollister-Whitney Elevator Corporation

#1 Hollister-Whitney Parkway
Quincy, IL 62305
Phone: 217-222-0466

Fax: 217-222-0493
e-mail: info@hollisterwhitney.com
www.hollisterwhitney.com

Hollister-Whitney Elevator Corporation

Repair and Maintenance Manual - Warner Brakes GL100, GL115, GL130 and GL170 Gearless Machines





Hollister-Whitney Elevator Corporation

#1 Hollister-Whitney Parkway
Quincy, IL 62305
Phone: 217-222-0466

Fax: 217-222-0493
e-mail: info@hollisterwhitney.com
www.hollisterwhitney.com

NOTE: The Warner Brake is no longer supplied on OEM GL Machines. All Current Manufacture GL Machines are supplied with MAYR BRAKES.

If it is necessary to replace your Warner Brake, a Mayr Brake of equivalent Size will be substituted.



BEFORE PERFORMING ANY MAINTENANCE ON THE MACHINE BRAKES, TAKE ALL THE NECESSARY SAFETY PRECAUTIONS TO IMMOBILIZE THE CAR AND COUNTERWEIGHT TO PREVENT ANY UNINTENDED MOVEMENT DURING THE MAINTENANCE PERIOD THAT MAY RESULT IN INJURY OR DEATH!

READ THE ENTIRE BRAKE REPLACEMENT PROCEDURE BEFORE BEGINNING ANY OF THE STEPS OUTLINED BELOW. CONTACT HOLLISTER-WHITNEY WITH ANY QUESTIONS PRIOR TO BEGINNING THE BRAKE REPLACEMENT.



BEFORE OPENING ANY ELECTRICAL ENCLOSURES ON THE MACHINE, REMOVE ALL ELECTRICITY FROM THE MACHINE AND BRAKES TO PREVENT ELECTRICAL SHOCK THAT MAY RESULT IN INJURY OR DEATH DURING THE MAINTENANCE PERIOD!

Table of Contents

- I. Checking Brakes
- II. Basic Service
 - a. Brake Adjustments
 - b. Brake Switch Adjustments
 - i. Procedure 1 Warner
 - c. Manual Brake Release Adjustments (if so equipped)
 - d. Brake Removal
 - e. Warner Brake Disassembly & Cleaning
 - f. Brake Install - Mayr
 - g. Warner Manual



Hollister-Whitney Elevator Corporation

#1 Hollister-Whitney Parkway
Quincy, IL 62305
Phone: 217-222-0466

Fax: 217-222-0493
e-mail: info@hollisterwhitney.com
www.hollisterwhitney.com

I. CHECKING BRAKES

While it may be Inconvenient to Check Brakes, especially on Machine Room-less applications (MRL'S), Inconvenience is NOT an excuse. Brakes should and MUST be checked.

On Gearless Machines the Main Service Brake and the Emergency Brake can be the same type of Brake and can have same Pick Voltage, the same Hold Voltage, etc. Be sure all Brake Switches are Operational and NEVER ignore a Brake or Brake Switch Failure, or worse, an Unintended Motion Fault. FIND THE CAUSE of the Fault or Failure.

Brake Failure: Some Possible Causes

- 1) Dirt or Dust in the Air Gap of the Brake.
 - Dirt or Dust in the Air Gap may cause the brake to not fully open when picked, and this in turn can cause the Brake to drag on the Rotor, cause premature wear on the Brake Pad, and ultimately wear out the Brake Pad. Use Compressed Air to blow the Dust and Dirt out of the Air Gap. The Brake should be Disassembled and Cleaned once a year (See Section **II.** e.)
- 2) The Brake Pick Voltage may be set too low.
 - Check the Pick Voltage when the Brake is hot. The Voltage to Pick a Cold Brake is different than the Voltage to Pick a Hot Brake. If the Brake does not fully Pick it may cause Excessive Lining Wear, and eventual Failure of the Brake.
- 3) The Brake Hold Voltage may be set too low.
 - If the Brake Hold Voltage is set too low the Brake may relax or even fall out after the initial Pick. If the Brake relaxes or falls out it may cause Excessive Lining Wear, and eventual Failure of the brake.
- 4) The Manual Release Arm may not be adjusted properly.
 - Check for at least 1/4 of an inch of movement in both directions when the Brake is Not Energized. If this Arm is set too tight the proper pressure on the Brake Pads may not be achieved. If the proper Brake Pad pressure is not applied the brake may not be able to Hold the Car.
 - To Test, Connect the Manual Release to the Emergency Brake ONLY. With the Car at the Top Landing with the Doors Closed, open the Emergency Brake and make sure the Main Service Brake holds the car. Then, with the Car at the Bottom Landing put 125% load in the Car and Open the Emergency Brake and make sure the Main Service Brake holds the car.
 - Repeat the test with the Manual Release connected only to the Main Service Brake.



Hollister-Whitney Elevator Corporation

#1 Hollister-Whitney Parkway
Quincy, IL 62305
Phone: 217-222-0466

Fax: 217-222-0493
e-mail: info@hollisterwhitney.com
www.hollisterwhitney.com

II. BASIC SERVICE

a. Brake adjustments

- Tools required - 3/4" wrench (or adjustable wrench) and 0.015" feeler gauge.
- The air gap on the brakes is preset from the factory at 0.015".
- After burnishing, the air gap must be re-verified and adjusted as necessary to ensure proper brake operation.
- Before you check or adjust the brake air gap, clamp the brake on the rotor (de-energize.) All adjustments and measurements will be made with the brake clamped on the rotor (de-energized.)
- Check the air gap at location "A", on both sides of the brake, as shown in Figure 1. The air gap should be 0.015".
- If the air gap does not measure 0.015", loosen the lock nuts, "B", and use the adjustment screws, "C", to set the air gap to 0.015". To **REDUCE** the air gap, turn the screws **INTO** the housing. To **INCREASE** the air gap, turn the screws **OUT** of the housing.
- Both screws must be adjusted to keep the air gap equal on both sides of the brake.
- After the air gap is set, re-tighten the lock nuts, "B."

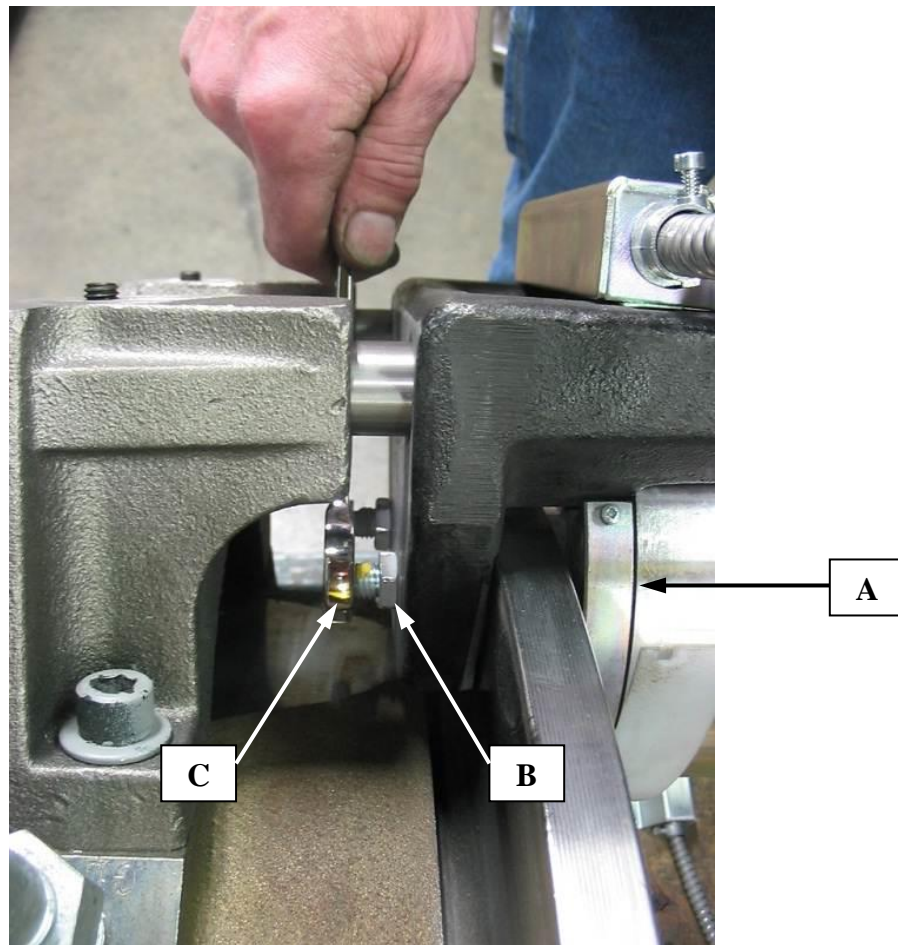

Figure 1



Hollister-Whitney Elevator Corporation

#1 Hollister-Whitney Parkway
Quincy, IL 62305
Phone: 217-222-0466

Fax: 217-222-0493
e-mail: info@hollisterwhitney.com
www.hollisterwhitney.com

b. Brake switch adjustments

- When the brake switch is clamped on the rotor (de-energized), the brake switch should **NOT** be actuated.
- To adjust the switch, clamp the brake on the rotor (de-energize) and follow the appropriate procedure below:

i. Warner

- Tools required - 8mm wrench, or adjustable wrench.
- Referring to Figure 2, loosen the lock nut, "A."
- Adjust screw "B" **IN** until the switch is barely actuated by pin "C."
- Once the switch is actuated, turn screw "B" back **OUT** by 1/6 of a turn so the switch is no longer actuated.
- Re-tighten lock nut "A" and test the brake and switch operation.

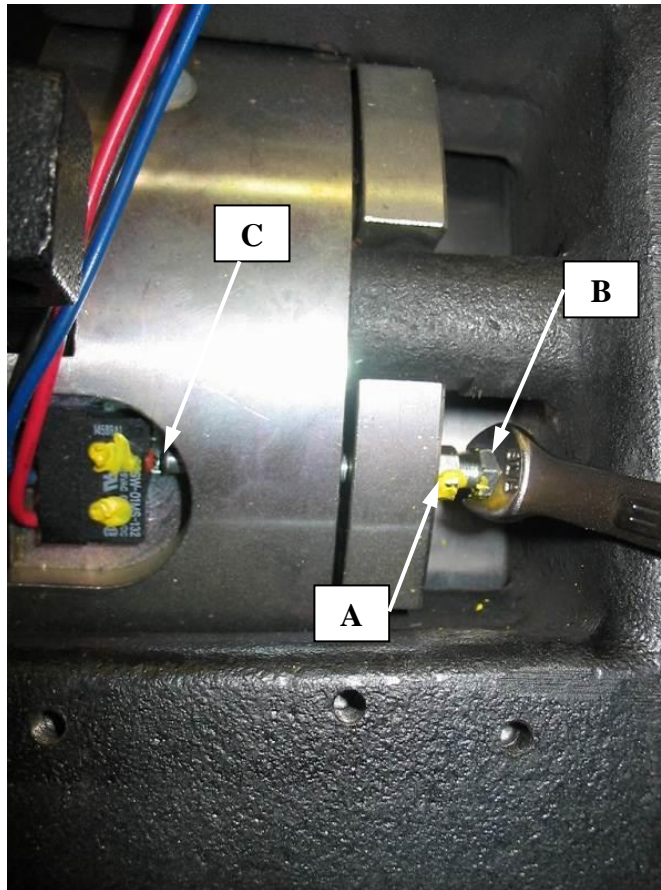

Figure 2 (cover removed for clarity)



Hollister-Whitney Elevator Corporation

#1 Hollister-Whitney Parkway
Quincy, IL 62305
Phone: 217-222-0466

Fax: 217-222-0493
e-mail: info@hollisterwhitney.com
www.hollisterwhitney.com

c. Manual brake release adjustments (if so equipped)

- Tools required - 3/8" wrench (or adjustable wrench)
- Leave the manual brake release handle in the "at-rest" position.
- With the brake release handle un-actuated, adjust nut, "A", in Figure 4 to take the slack out of the cable, but not tight enough to actuate the manual release arm on the brake.
- Once the slack has been removed, tighten the jam nut, "B", against the adjustment nut, "A", in Figure 19.
- Actuate the manual brake release handle to ensure the brake opens manually, and returns to the clamped position when the handle is returned to the "at-rest" position.

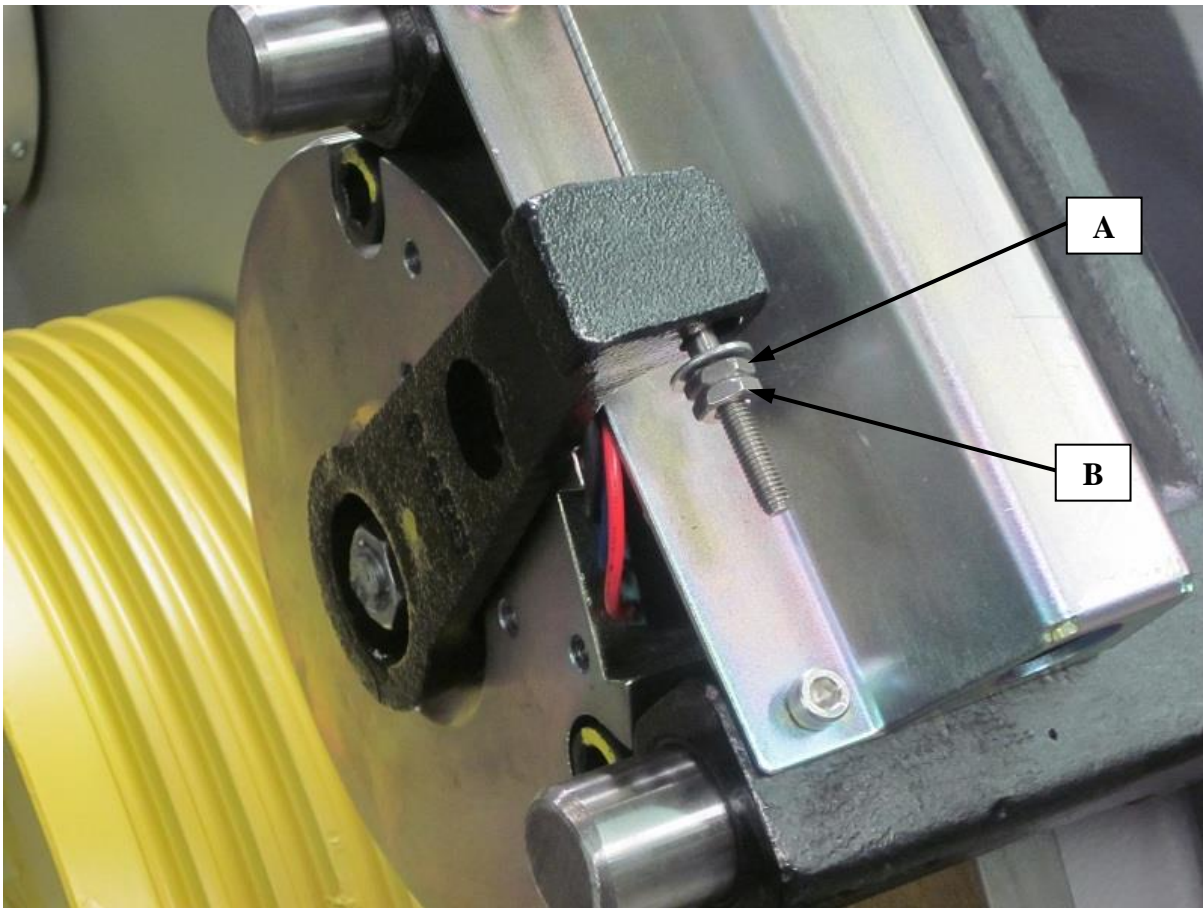

Figure 4



Hollister-Whitney Elevator Corporation

#1 Hollister-Whitney Parkway
Quincy, IL 62305
Phone: 217-222-0466

Fax: 217-222-0493
e-mail: info@hollisterwhitney.com
www.hollisterwhitney.com

d. Brake Removal



BEFORE PERFORMING ANY MAINTENANCE ON THE MACHINE BRAKES, TAKE ALL THE NECESSARY SAFETY PRECAUTIONS TO IMMOBILIZE THE CAR AND COUNTERWEIGHT TO PREVENT ANY UNINTENDED MOVEMENT DURING THE MAINTENANCE PERIOD THAT MAY RESULT IN INJURY OR DEATH!



BEFORE PERFORMING ANY MAINTENANCE ON THE MACHINE BRAKES, REMOVE ALL ELECTRICITY FROM THE MACHINE AND BRAKES TO PREVENT ANY UNINTENDED MOVEMENT THAT MAY RESULT IN INJURY OR DEATH DURING THE MAINTENANCE PERIOD!

READ THE ENTIRE BRAKE REPLACEMENT PROCEDURE BEFORE BEGINNING ANY OF THE STEPS OUTLINED BELOW. CONTACT HOLLISTER-WHITNEY WITH ANY QUESTIONS PRIOR TO BEGINNING THE BRAKE REPLACEMENT.

- Tools required - Flat, small screwdriver (for terminal blocks), pliers or flat, large screwdriver (for conduit nut), 3/16" hex key, 3/8" hex key, 3/8" wrench, 11/16" wrench (or adjustable wrench), hammer and punch.
- Before removing the old brake from the machine, verify the new brake is the same model and voltage as the brake that is being replaced. If the new brake is different than the brake being replaced, contact Hollister-Whitney.
- For machines equipped with the Hollister-Whitney manual brake release cable, begin by removing jam nut "A", nut "B" and washer "C." Then, loosen nut "D." Refer to Figure 5.

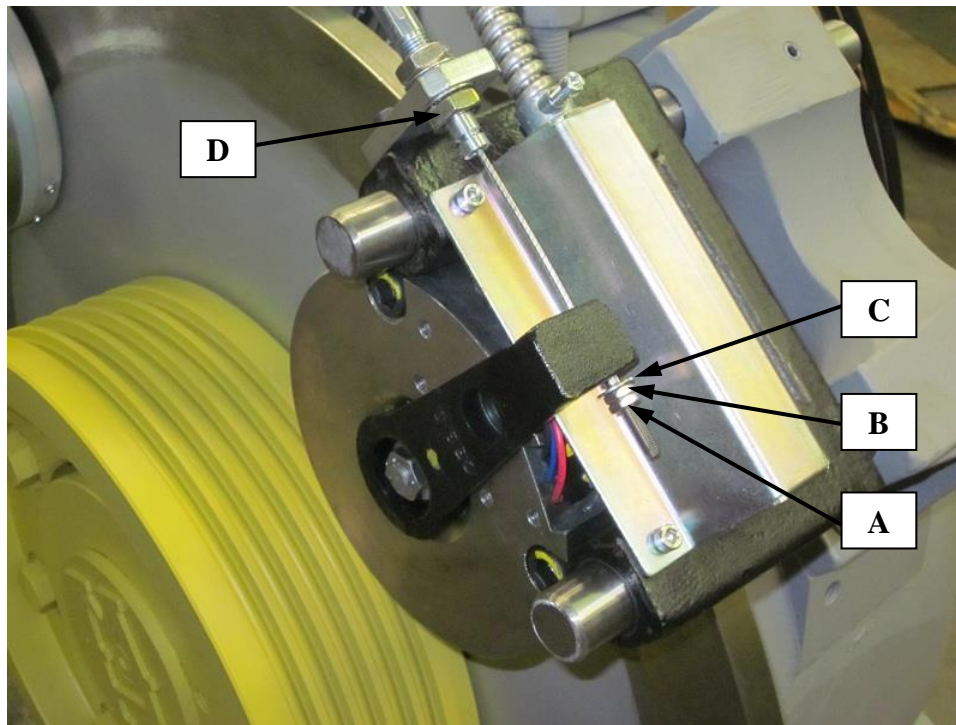

Figure 5



Hollister-Whitney Elevator Corporation

#1 Hollister-Whitney Parkway
Quincy, IL 62305
Phone: 217-222-0466

Fax: 217-222-0493
e-mail: info@hollisterwhitney.com
www.hollisterwhitney.com

- Once the manual brake release cable hardware has been removed and loosened, slide the brake release cable out of the brake. Refer to Figure 6.

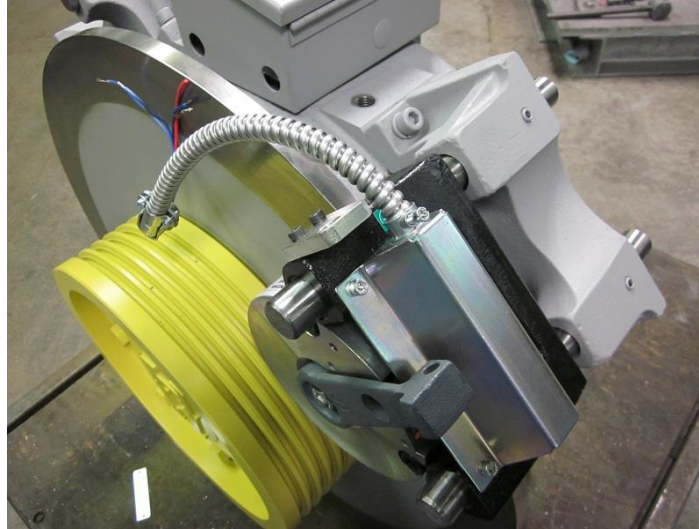

Figure 6 (manual brake release cable removed)

- After the manual brake release cable has been completely removed, it is time to disconnect the electrical wires to the brake.



BEFORE REMOVING ANY WIRES FROM THE ELECTRICAL ENCLOSURE, WRITE DOWN THE WIRE COLORS AND TERMINAL BLOCK DESIGNATIONS FOR FUTURE REFERENCE! THIS INFORMATION WILL BE NECESSARY WHEN CONNECTING THE WIRES FOR THE NEW BRAKE!

- After writing down the wire colors and terminal block designations, remove the proper brake wires from the terminal blocks and remove the conduit nut "A." Refer to Figure 7.

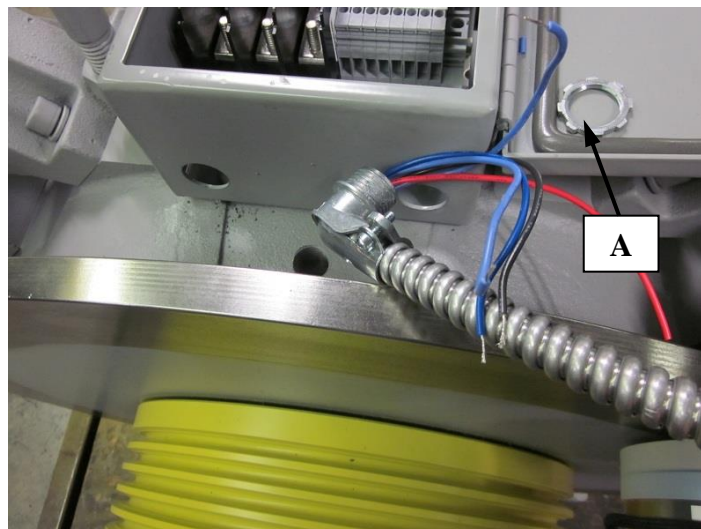

Figure 7



Hollister-Whitney Elevator Corporation

#1 Hollister-Whitney Parkway
Quincy, IL 62305
Phone: 217-222-0466

Fax: 217-222-0493
e-mail: info@hollisterwhitney.com
www.hollisterwhitney.com

- Once the wires have been removed from the electrical enclosure, Loosen, do not remove the 3 brake retaining bolts “A” on the front of the brake itself. 1 bolt may be behind tag as shown in Figure 8. This will allow for removal of brake without having to energize the brake.

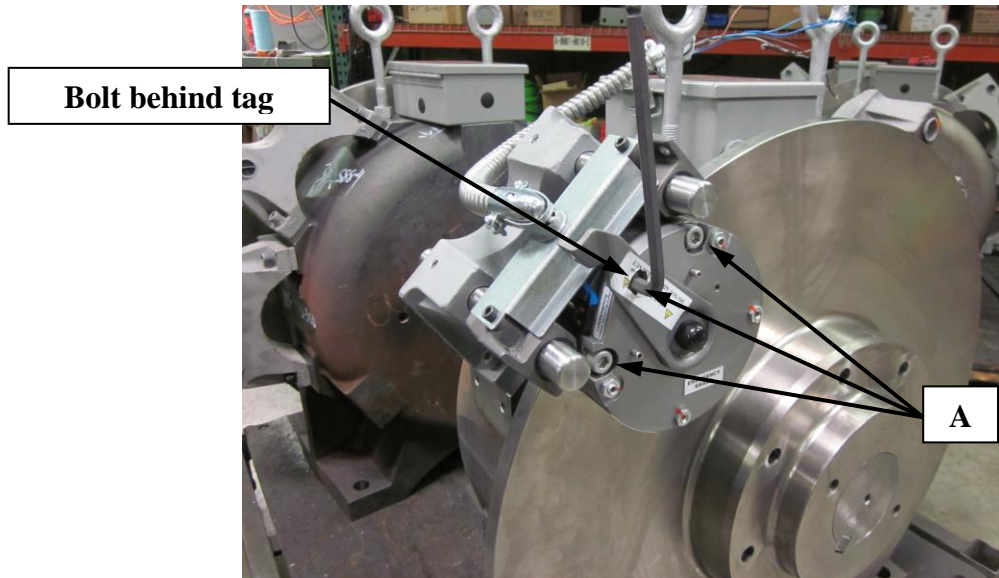

Figure 8

- After the loosening brake bolts, remove the 4 bolts in the brake base holding the entire brake assembly to the housing. Refer to Figure 9. Move brake assembly to a work area, then remove brake from base. See figure 10



Figure 9



Hollister-Whitney Elevator Corporation

#1 Hollister-Whitney Parkway
Quincy, IL 62305
Phone: 217-222-0466

Fax: 217-222-0493
e-mail: info@hollisterwhitney.com
www.hollisterwhitney.com



Figure 10

e. Warner Brake Disassembly and Cleaning

- Warner Brakes are prone to dust generation and contamination. Prior to disassembly, blow out brake with Compressed Air. Spray Brake Cleaner into Air Gap and blow dry with Compressed Air. If performance of Brake Does Not return to normal, proceed with Disassembly and Cleaning.

Minimum Tools Required:

- 1) 4mm, 8mm & 10mm Allen Wrenches,
- 2) Ratchet with 18mm Socket
- 3) Phillips Head Screw Driver
- 4) 2x 3" C-clamps
- 5) Putty Knife
- 6) Compressed Air Can
- 7) Brake Cleaner Spray
- 8) Nonmetallic Scouring Pads
- 9) Clean-up Cloth or Rags
- 10) Medium Strength Thread Locker



Hollister-Whitney Elevator Corporation

#1 Hollister-Whitney Parkway
Quincy, IL 62305
Phone: 217-222-0466

Fax: 217-222-0493
e-mail: info@hollisterwhitney.com
www.hollisterwhitney.com

Disassembly & Cleaning

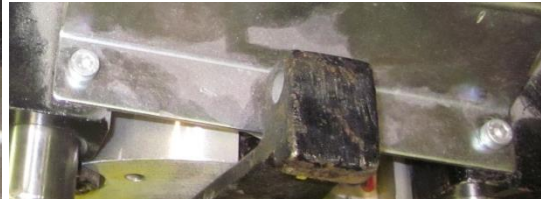
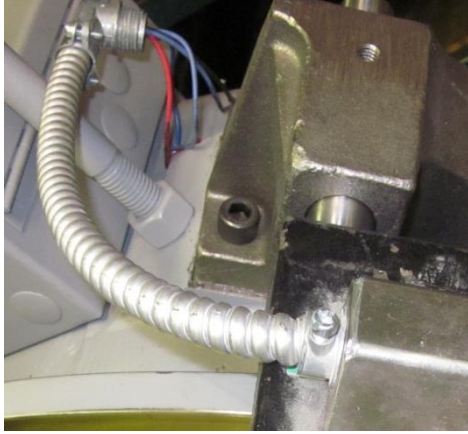

- Disconnect Brake wires inside Terminal Box on Machine
- Disconnect Conduit from Terminal Box on Machine
- Remove 2 Screws from Junction Cover on Brake

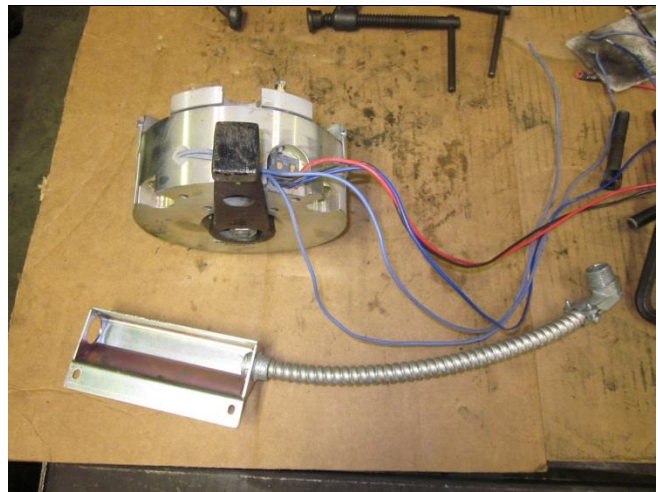
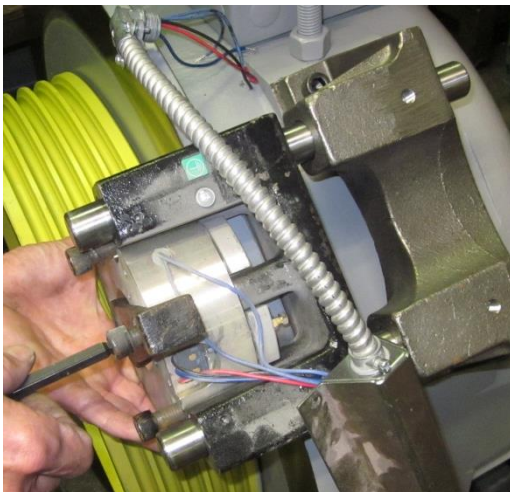

- Remove 3 Bolts from Front of Brake that holds Brake Coil Assembly to Caliper Guide. Remove Brake Coil Assembly to a convenient work table. It may be convenient to remove the Conduit and Junction Cover from the Brake Coil Assembly at this time.
- Measure and Note the Air Gap between the Brake Shoe Plate and Coil Assembly.



Hollister-Whitney Elevator Corporation

#1 Hollister-Whitney Parkway
Quincy, IL 62305
Phone: 217-222-0466

Fax: 217-222-0493
e-mail: info@hollisterwhitney.com
www.hollisterwhitney.com



- Clamp Brake Coil Assembly shut with 2 C-Clamps.

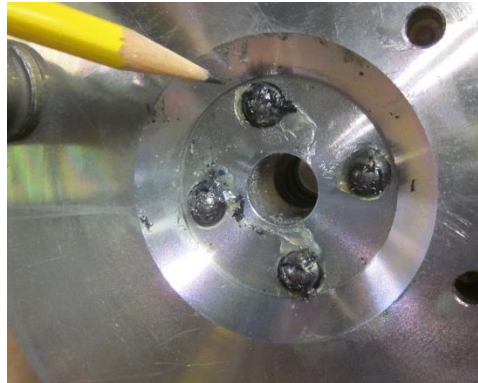

- Unbolt the Brake Release Lever. Note; this bolt is under some spring pressure. Care should be taken when releasing. Take note of small parts and ball bearings.



Hollister-Whitney Elevator Corporation

#1 Hollister-Whitney Parkway
Quincy, IL 62305
Phone: 217-222-0466

Fax: 217-222-0493
e-mail: info@hollisterwhitney.com
www.hollisterwhitney.com

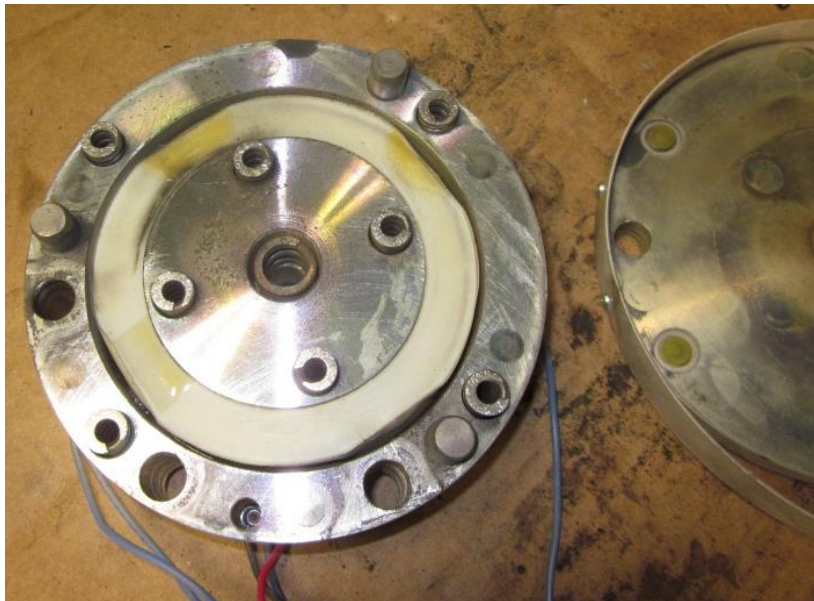
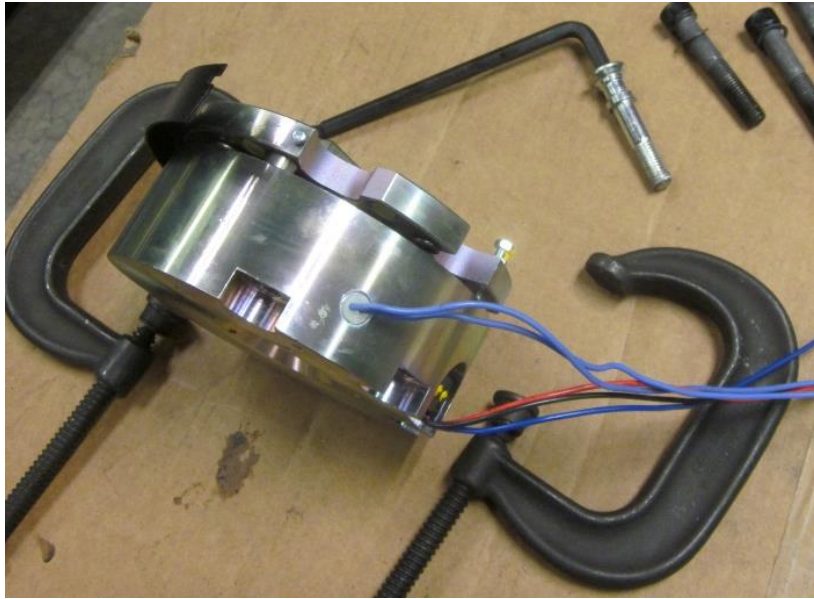

- Release C-Clamps evenly and remove Brake Shoe Plate from Coil Assembly



Hollister-Whitney Elevator Corporation

#1 Hollister-Whitney Parkway
Quincy, IL 62305
Phone: 217-222-0466

Fax: 217-222-0493
e-mail: info@hollisterwhitney.com
www.hollisterwhitney.com

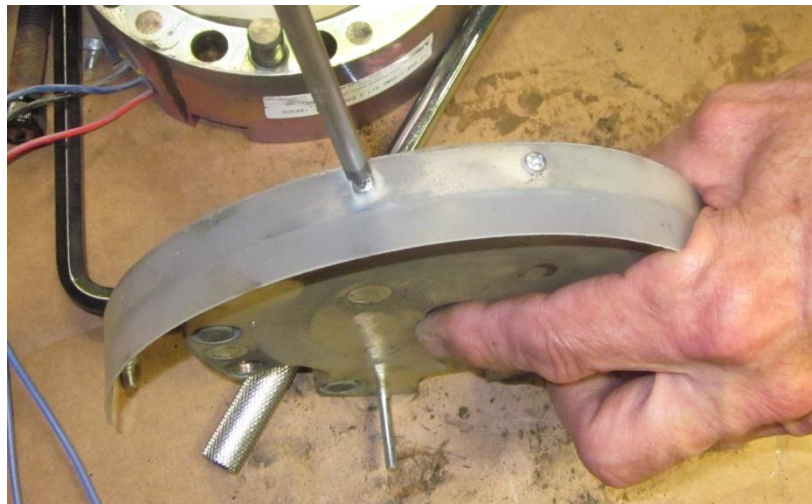

- Remove Compression Springs (8), Compression Washers (8), Brake Lever Spring, and Plastic Brake Shield.



Hollister-Whitney Elevator Corporation

#1 Hollister-Whitney Parkway
Quincy, IL 62305
Phone: 217-222-0466

Fax: 217-222-0493
e-mail: info@hollisterwhitney.com
www.hollisterwhitney.com



- Using Brake Cleaner, Scouring Pad, and Putty Knife as necessary, clean faces of Brake Shoe Plate and Coil Assembly, and clean Guide Pins and Holes.
- When Clean and Dry, reassemble, taking care not to forget the Compression Washer under each Compression Spring.



Hollister-Whitney Elevator Corporation

#1 Hollister-Whitney Parkway
Quincy, IL 62305
Phone: 217-222-0466

Fax: 217-222-0493
e-mail: info@hollisterwhitney.com
www.hollisterwhitney.com

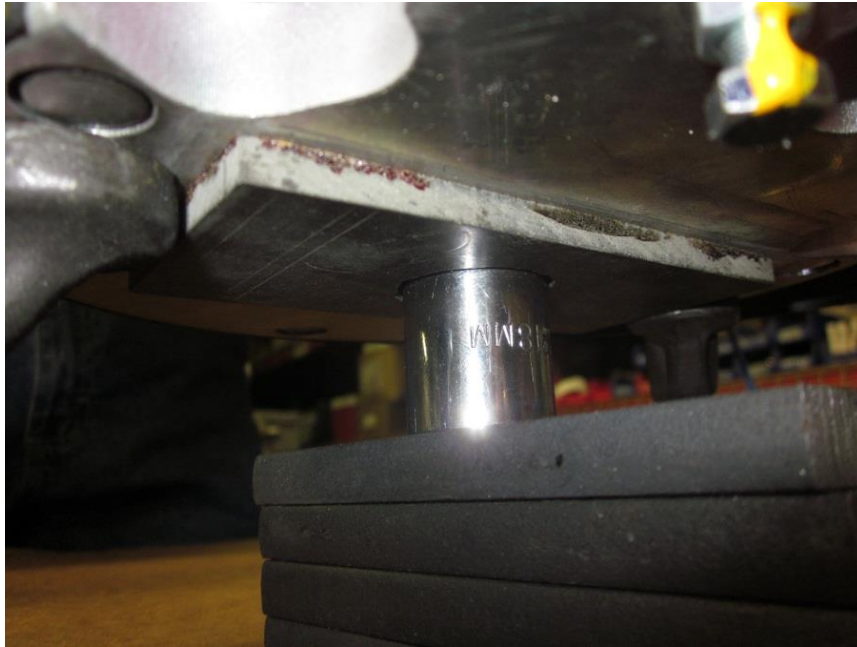

- To reassemble the Brake Lever, use the 18mm Socket to help compress the Brake Lever Bolt to get the nut started.

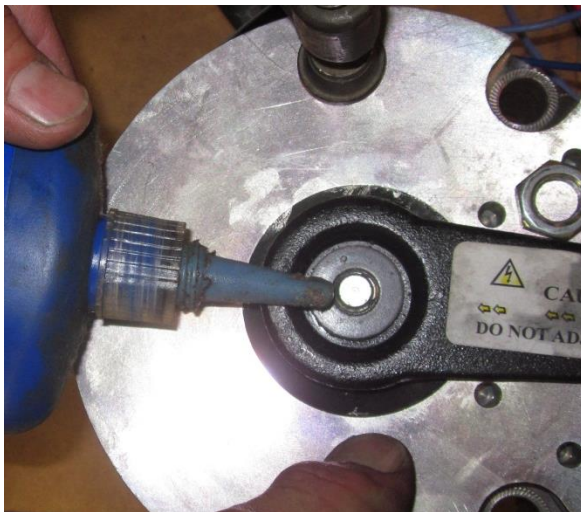

- Use Medium Strength Threadlocker on all Bolted Connections.
- Retighten Brake Lever Bolt to the Air Gap previously noted.
- Reassemble Brake Coil Assembly to the Caliper Guide, and complete Electrical Connections.
- Adjust Brake as Necessary for 0.015" Air Gap

- f. **Brake Replacement – Mayr** See Bulletin 1158 Section III and IV at:
<http://www.hollisterwhitney.com/#tech-support>
- g. **Warner Brake – Service Manual – See Following Document.**



Hollister-Whitney Elevator Corporation

#1 Hollister-Whitney Parkway
Quincy, IL 62305
Phone: 217-222-0466

Fax: 217-222-0493
e-mail: info@hollisterwhitney.com
www.hollisterwhitney.com

THIS SPACE INTENTIONALLY BLANK

SM381gb - rev 10/07

Electrically Released Brakes ERS VAR11-01 FT = 3600 N

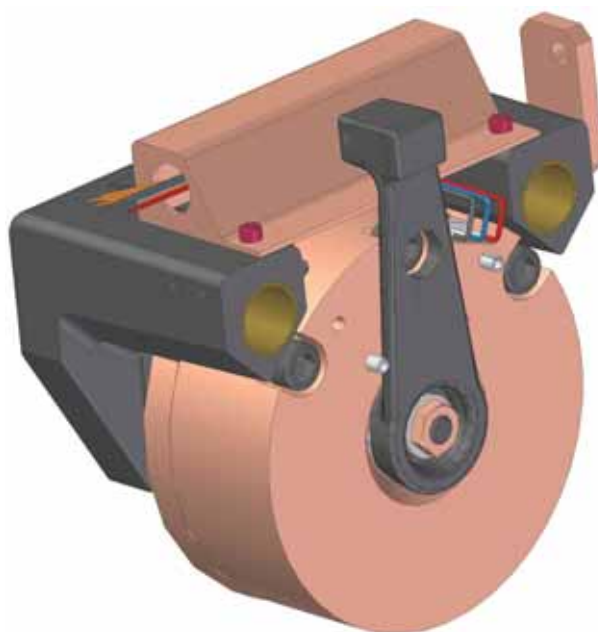

EC type certificate ABV 769
According to drawing 1 12 106881



Industrie Service

We, **WARNER ELECTRIC EUROPE**, 7, rue Champfleury, B.P. 11095, F-49182 St Barthélemy d'Anjou Cedex declare that the brakes made in our factory from St Barthélemy d'Anjou,

and hereafter designated: **ERS VAR11-01**

Fully comply with directive 95/16/EC on Lifts and are intended for incorporation into an installation or for assembly with other equipment, with the aim of constituting a machine subject to the application of directive 98/37/EC and the directive on Electromagnetic Compatibility 89/336 (modified).

Compliance with the basic requirements of the Low Voltage Directive 73/23 (modified) is guaranteed by our full compliance with the following standards: NFC 79300 and VDE 0580/8.65.

Drawn up in St Barthélemy d'Anjou, July 2002
E. PRAT, General Managing Director

CONTENTS

1	Technical specifications	2	4	Maintenance	4
2	Precautions and restrictions on use	3	4.1	Adjusting the airgap	4
2.1	Restrictions on use	3	4.2	Adjusting the microswitch	5
2.2	Precautions and safety measures	3	5	Electrical connection	5
3	Installation	3	5.1	Important recommendations	5
3.1	Transport - storage	3	5.2	Grounding	5
3.2	Handling	3	6	Spare parts	6
3.3	Installation mounting	3-4	7	Tools	6
3.3.1	Hand lever configuration	4	8	Troubleshooting	6
3.3.2	Installation	4			

1 Technical specifications

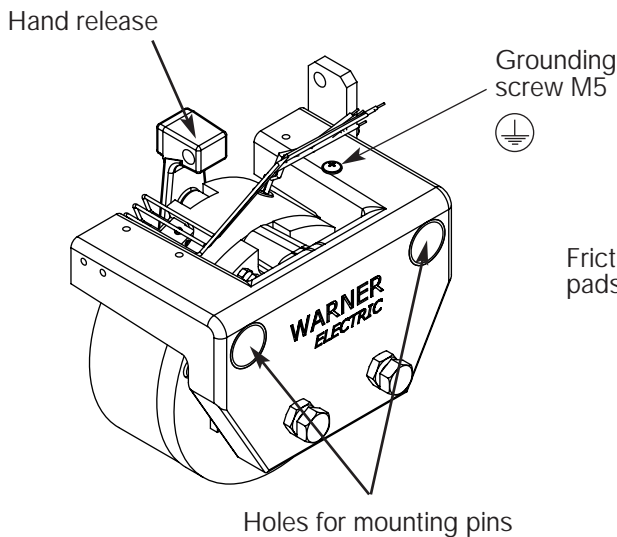

Fig. 1

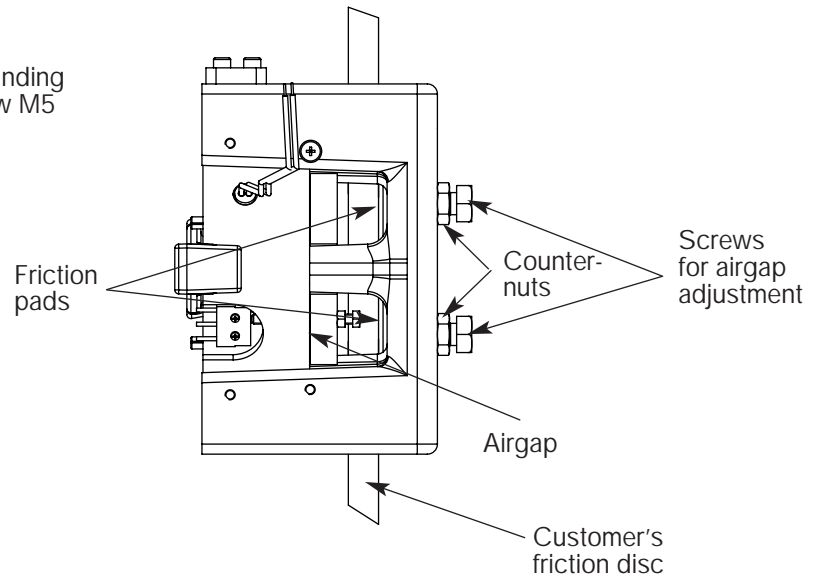

Fig. 2

Table 1		ERS VAR11-01		
Warner Electric Part Number		1800 to 3600 (according version)		
Tangential force of braking	N	8		
Maximum linear speed (outside \varnothing disc)	m/s	0,3 +0,1/0		
Nominal airgap	mm	0,6		
Maximum airgap after wear	mm	48	103	207
Overexcitation voltage	VDC	24	52	103
Holding voltage	VDC	14,4	60,8	210
Resistance	Ohm	160	176	204
Power (overexcitation)	W	40	44,5	51
Power (holding)	W	60		
Cyclic duration factor ED	%	14,3		
Weight	kg	1000		
Maximum force on the hand lever	N			



Symbol designating an action that might damage the brake



Symbol designating an action that might be dangerous to human safety



Symbol designating an electrical action that might be dangerous to human safety

2.1 Precautions and restrictions on use

2.1 Restrictions on use



For the brake to comply with directive 95 / 16 / EC, the installer must observe the general conditions for installations and use as defined in the EC type certificate ref. ABV 769 of 14th October 2005 drawn up by the TÜV Munich, including the mandatory use of a speed limiting device, in compliance with EN 81-1 paragraphs 9.9 and 9.10.10.



This brake is designed to work in dry conditions. Friction faces must be kept completely clean of any oil, grease or abrasive dust which might deteriorate their performances.



If maximum rotation speeds are exceeded, the guarantee is no longer valid.



This brake must not be dismantled



This brake may only be used in a "horizontal axis". The customer must be careful not to alter the factory-set airgap and the working clearance of the brake and the hand lever



This brake is designed for a maximum ambient temperature of 40°C (insulation class 155°C). The maximum temperature in continual use is 100°C.



This brake is designed for static applications. Any dynamic braking is restricted to emergency braking and test braking. This brake can in no way replace the safety braking system used during lift descent.



When connecting the conduits on the conduit box (see Fig. 4), the customer must avoid any restraint, able to prevent the self-floating of the brake.

2.2 Precautions and safety measures



During maintenance, make sure that the mechanism to be braked by the brake, is stopped and that there is no risk of it accidentally starting up. All intervention have to be made by qualified personnel, owning this manual.



Any modification made to the brake without the express authorisation of a representative of Warner Electric, in the same way than any use out of the contractual specifications accepted by "Warner Electric", will result in the warranty being invalidated and Warner Electric will no longer be liable in any way with regard to conformity.



When switching on DC-side the coil must be protected against voltage transients.

3 Installation

3.1 Transport / storage

This brake is delivered in standard packaging that will keep it intact for a period of 6 months during ground, air or sea transport towards neighbouring continents (without crossing the tropics).

3.2 Handling



Avoid any impact to the brake so that its performance is not impaired.



Never lift the brake by its cables

3.3 Installation mounting



In case of long storage, check the brakes, before setting the drives, in order to avoid, in case of large temperature variation, any risk of sticking from the friction material, able to hindrance the start of the drive.



Data for customer friction disc :

Material: steel (150 to 250 HV) or cast iron, thickness of the friction disc: 15 mm +0/-0,1, roughness of the friction faces: Ra ≤ 3,2

Protection: dry phosphatizing or Nitriding

Geometric tolerances:

	0,1	Friction face / Pulley axis
	0,1	



Data for mounting pins :

Material: steel (min. 900 N/mm²), diameter 25h8, roughness: Ra ≤ 0.8

Protection: dry phosphatizing or Nitriding

//	0,1	Support axis / Pulley axis
----	-----	----------------------------

3.3.1 Hand lever configuration

According to the hand lever side of actuation, the customer must fit the pins, for limitation of the hand lever travel, in the selected position. Dimension of the pin out of the magnet: 6 max. (see Fig. 7).

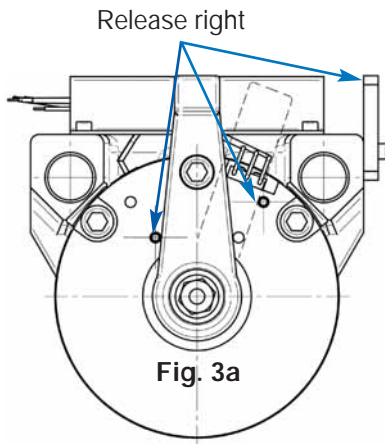

Fig. 3a

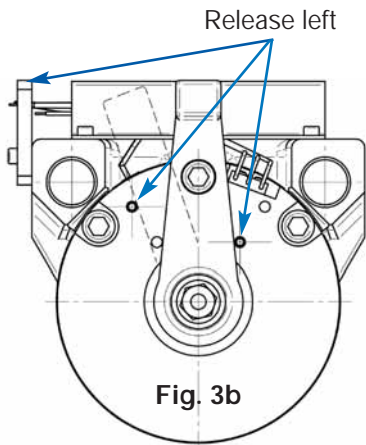

Fig. 3b

3.3.2 Installation

The brake is delivered pre-assembled with pre-set microswitches and airgaps.

- Engage the brake, armature attracted under voltage or with hand release, on his disc

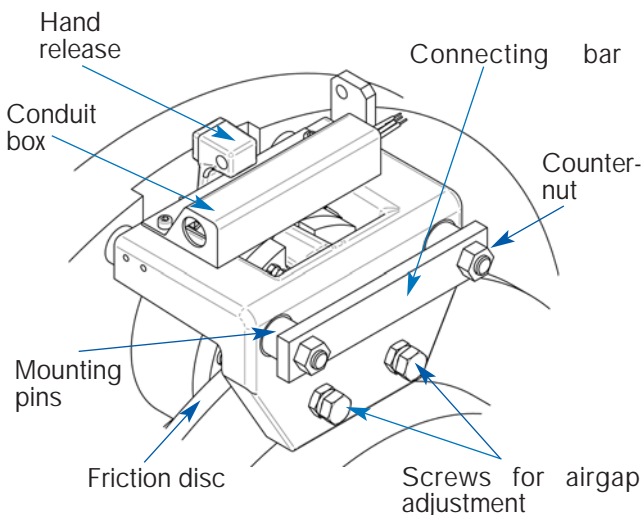

Fig. 4

- Mount the mounting pins, then the connecting bar and tighten with the indicated torque for the locknuts



This brake may only be used in a "horizontal axis". The customer must be careful not to alter the working clearance of the brake and the hand lever

4 Maintenance

4.1 Adjusting the airgap



Check the airgap at each maintenance inspection.



Reminder: This brake is intended for a static application as a safety brake. Any dynamic braking is restricted to emergency and test braking. Normal use will not lead to any noticeable wear on the lining.



The airgap adjustment must be reset before the max. airgap is reached. This to eliminate any functional problems because of the hand release travel.

- Slide two feeler gauges 0,3 mm thick in the airgap, avoiding the dampers, between the armature and the magnet (Fig. 5)

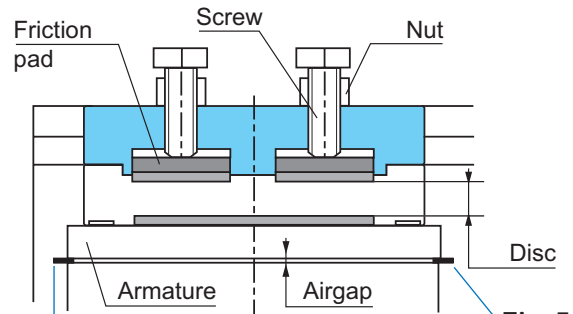
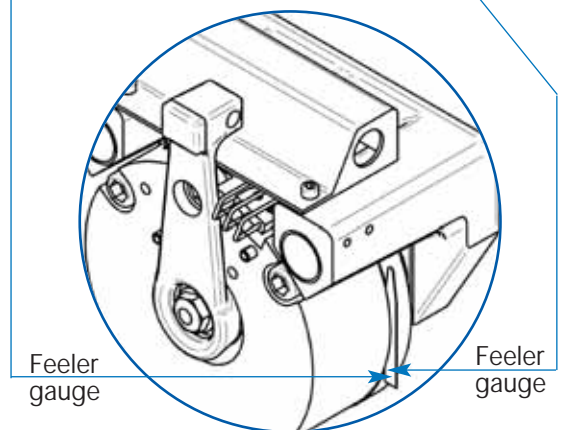

Fig. 5



- Energize magnet
- Tighten the airgap adjusting screws H M12 (18 A/F), until you reach contact, with a torque of 2 Nm.
- Tighten the counter nut (18 A/F) with a torque of 40 Nm \pm 4 Nm in holding the screw to avoid it rotating

Checking airgap area, see Fig. 6.

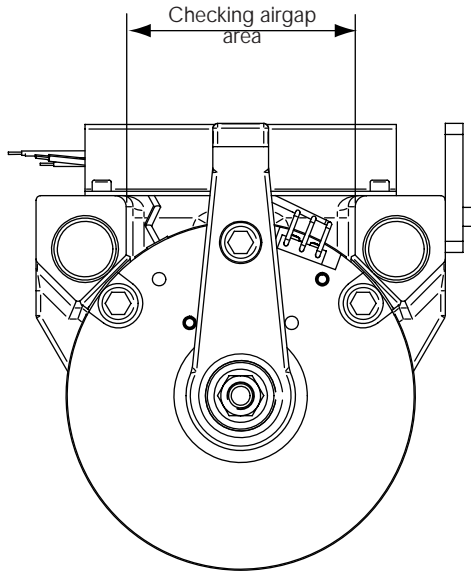

Fig. 6

4.2 Adjusting the microswitch

- Remove the conduit box to reach the airgap.
- Slide a feeler gauge 0,10 mm thick near the screw between the face of the magnet and the moving armature. Switch on the current and tighten the adjusting screw H M5 (8 A/F) in contact with the microswitch until you reach the trip point (Fig. 7).
- Check that it functions correctly by switching the power on and off several times ensuring the microswitch is activated correctly.

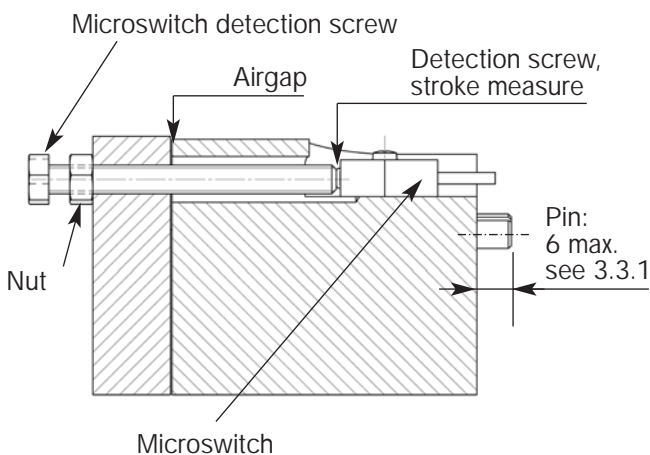

Fig. 7

Operation microswitch

Current range 10 mA min. to 100 mA max. at 24 VDC

Maximum electrical lifetime of the microswitch ensure only by switching under resistive load.

Microswitch connection

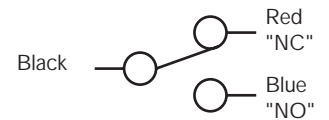

5 Electrical connection

Brake ERS VAR 11-01 operates on a direct current supply. Polarity does not affect the way the brake operates.

5.1 Important recommendations



All works on the electrical connections have to be made with power off.



Make sure that the nominal supply voltage is always maintained. A lack of power results in a reduction to the maximum airgap.



Emergency braking : for emergency braking the switching OFF must be connected on DC current side, in order to obtain short engaging time of the brake.

Service braking : for service braking, the switching OFF and the switching ON must be connected on AC current side, in order to obtain silent switching.

The connecting wires must be thick enough to help prevent sudden drops in voltage between the source and the brake.

Tolerances on the supply voltage at the brake terminals +5% / -10% (NF C 79-300).

5.2 Grounding

To be compliant with VDE 580, the customer must ground the brake (see Fig. 1). Grounding screw and safety washer supplied.

6 Spare parts

Part	Part number
Friction pads	BT 2 12 095534
Microswitch	BT 7 67 000466

7 Tools

Tools	Function
Feeler gauge	Airgap & microswitch adjustment
Open jawed spanner 18 mm A/F	Airgap adjustment
Torque wrench (measurement range > 50 Nm) with open ended spanner attachment 18 mm A/F	Airgap adjustment
Open jawed spanner 8 mm A/F	Microswitch adjustment
Multimeter	Voltage checking

8 Troubleshooting and fault elimination

Troubleshooting		
Fault	Cause	Remedy
Brake does not release	<ul style="list-style-type: none"> Supply voltage too low Power supply is interrupted Airgap too large Worn friction pads Coil is damaged Airgap too small Overexcitation time too short 	<ul style="list-style-type: none"> Check and adjust supply voltage Reconnect power supply, check the adjustment of microswitch Re-adjust the airgap (chapter 4.1) Replace pads Replace the brake Re-adjust the airgap (chapter 4.1) Increase overexcitation time
Brake does not engage	<ul style="list-style-type: none"> Voltage present at switch off position Grease on friction faces Hand release lever actuated 	<ul style="list-style-type: none"> Check the microswitch's adjustment and the customer's power supply Clean the disc and replace the brake Release the lever
Nuisance braking	<ul style="list-style-type: none"> Holding voltage too low State of microswitch incorrect 	<ul style="list-style-type: none"> Check and adjust the holding voltage Re-adjust the microswitch

Subject to alteration without prior notice