

DRUM BRAKE ADJUSTMENTS, MODELS #90, #100, #110 & #120 #102-091 BRAKE MONITOR

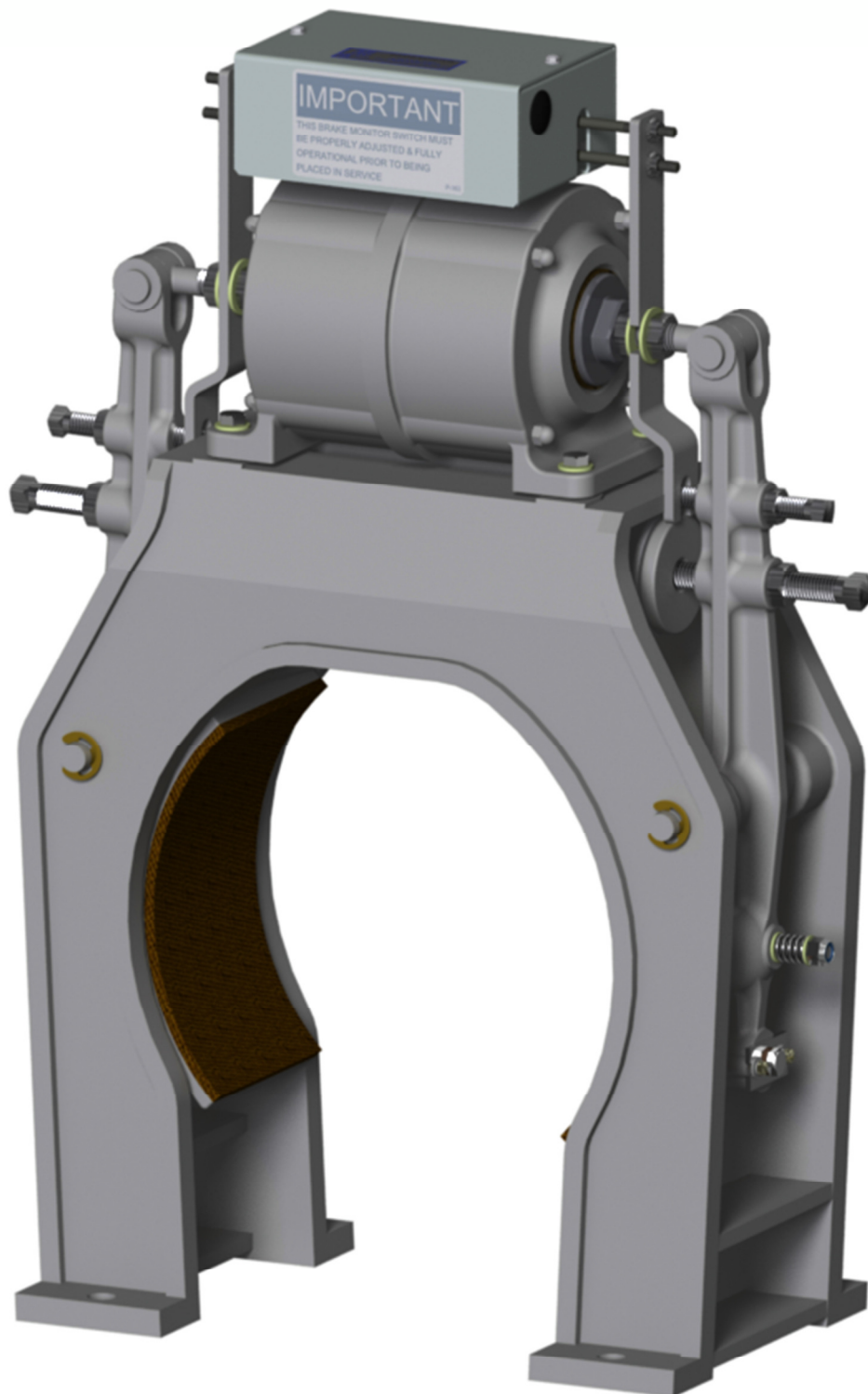

HOLLISTER-WHITNEY DRUM BRAKE WITH MONITOR ADJUSTMENTS

IMPORTANT: READ ENTIRE INSTRUCTIONS BEFORE ATTEMPTING ADJUSTMENT!!!
SHOCK WARNING: ACTIVE ELECTRIC CIRCUITS!!

1. Energize and de-energize solenoid to determine that each plunger moves an equal distance, meeting in center with equal amounts protruding from housing. Adjust spring adjustment screws to assure this centering.
2. Make sure there is approximately 1/32" between each centering screw and the housing when the solenoid is energized (i.e. plungers make contact). **IMPORTANT:** DO NOT use centering screws as stops to limit the travel of either plunger.
3. Turn heel and toe adjustment bolt, with solenoid energized, to adjust top and bottom of shoes to get equal drum clearance. Clearance between shoes and drum may be increased or decreased by adjusting plunger eye bolts (by rotating plungers) equally on each plunger. Final drum clearance should be 0.005". Re-adjust centering screws so they are spaced properly to the housing as described in 2.) above.
4. With the heel and toe adjusting plate screws partially tightened, lightly tap side of adjusting plate to correct twisting motion created when shoe contacts drum face. Re-adjust heel and toe main bolt for clearance between shoe and drum.
5. Run car to determine overall Brake performance. Spring tension may have to be varied to obtain harder or softer stops and can only be determined by specific job conditions.

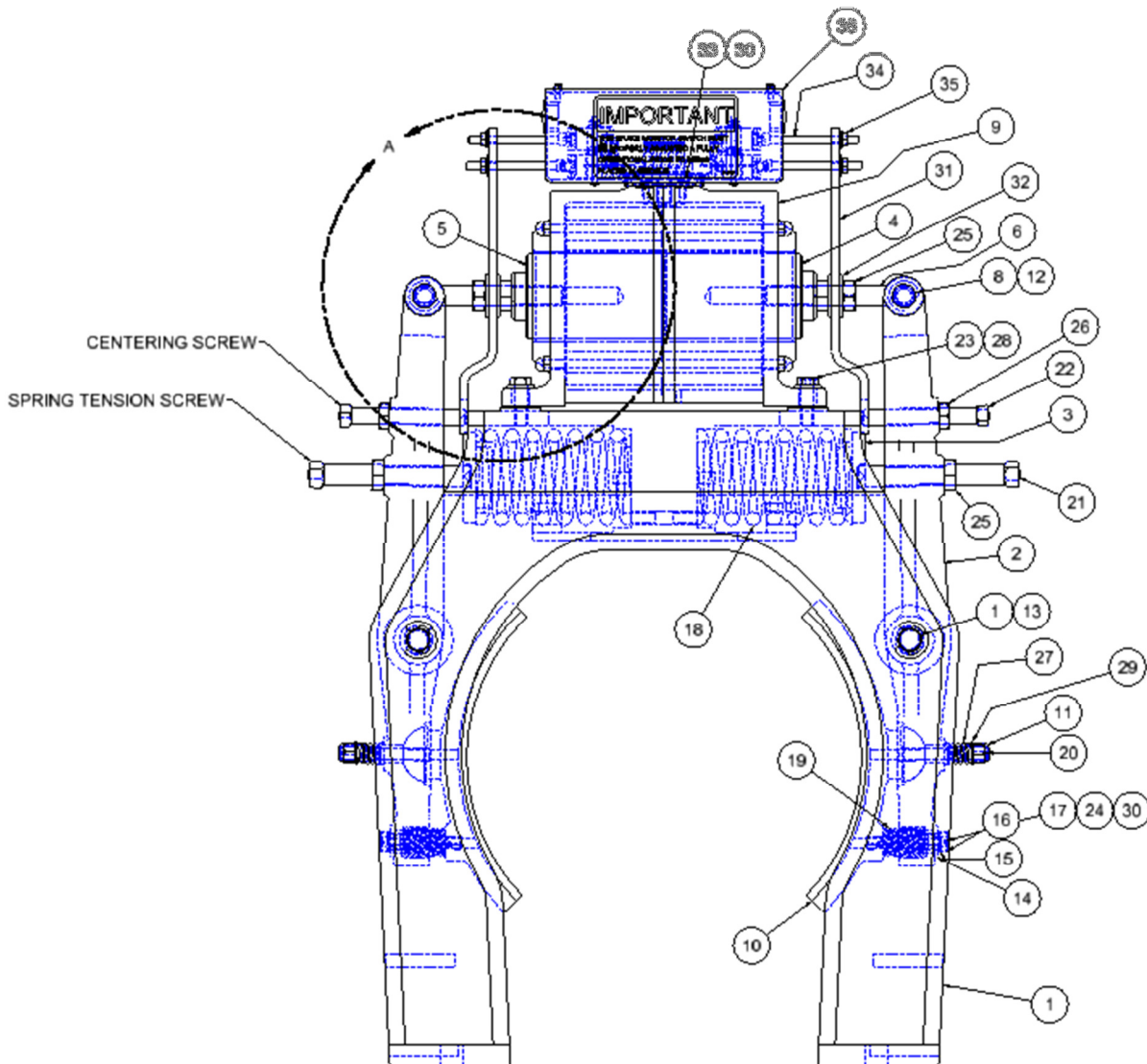

DRUM BRAKE PARTS LIST													
ITEM	90 (10" DRUM)			100 (12" DRUM)			110 (14" DRUM)			120 (16" DRUM)			DESCRIPTION
	QTY	PART NUMBER		QTY	PART NUMBER		QTY	PART NUMBER		QTY	PART NUMBER		
1	1	90-001		1	100-001		1	110-001		1	120-001		BRAKE HOUSING
2	2	90-003A		2	90-003A		2	110-003A		2	120-003A		BRAKE LEVER w/ BUSHING
3	2	90-005		2	90-005		2	90-005		2	90-005		CAP - BRAKE SPRING
4	1	90-006		1	90-006		1	90-006		1	120-006		PLUNGER - BRAKE
5	1	90-007		1	90-007		1	90-007		1	120-007		PLUNGER w/ PLUNGER RING
6	2	90-064		2	100-008		2	100-008		2	90-008		PLUNGER EYEBOLT
7	2	90-012		2	100-012		2	110-012		2	120-012		PIN - BRAKE LEVER
8	2	90-013		2	90-013		2	90-013		2	90-013		PIN - 0.625" DIA.
9	1	90-028		1	90-028		1	90-028		1	120-028		BRAKE SOLENOID ASSEMBLY
9A	1	90-035		1	90-035		1	90-035		1	120-035		115V COIL
9B	1	90-022		1	90-022		1	90-022		1	120-022		230V COIL
10	2	90-029A		2	100-029A		2	110-029A		2	120-029A		BRAKE SHOE ASSEMBLY
11	2	90-030		2	90-030		2	90-030		2	90-030		3/8 NYLON LOCK NUT
12	2	90-032		2	90-032		2	90-032		2	90-032		E-CLIP, #5133-62
13	4	90-033		4	90-033		4	90-033		4	90-033		E-CLIP, #X5133-74
14	2	90-036		2	90-036		2	90-036		2	90-036		PLATE - HEEL & TOE ADJUSTMENT
15	2	90-045		2	90-045		2	90-045		2	90-045		BUSHING
16	2	90-038		2	90-038		2	110-038		2	110-038		BOLT - HEEL & TOE ADJUSTMENT
17	4	90-039		4	90-039		4	90-039		4	90-039		WASHER
18	2	400-032		2	400-032		2	400-032		2	400-034		SPRING - LEVER
19	2	400-039		2	400-039		2	400-039		2	400-019		SPRING - SHOE
20	2	500-023		2	500-023		2	500-023		2	500-023		STUD
21	2	5/8 - 11 UNC X 4		2	5/8 - 11 UNC X 4.5		2	5/8 - 11 UNC X 5		2	5/8 - 11 UNC X 4		SCREW, SQ HD SET
22	2	1/2 - 13 UNC X 3.5		2	1/2 - 13 UNC X 3.5		2	1/2 - 13 UNC X 4		2	1/2 - 13 UNC X 5		SCREW, SQ HD SET
23	4	3/8 - 16 UNC X 1.25		4	3/8 - 16 UNC X 1.25		4	3/8 - 16 UNC X 1.25		4	3/8 - 16 UNC X 1.5		HEX HEAD CAP SCREW
24	4	#10-32 X 0.5		4	#10-32 X 0.5		4	#10-32 X 0.5		4	#10-32 X 0.5		SCREW, FILLISTER HEAD
25	6	5/8 - 11 UNC		6	5/8 - 11 UNC		6	5/8 - 11 UNC		6	5/8 - 11 UNC		HEX JAM NUT
26	2	1/2 - 13 UNC		2	1/2 - 13 UNC		2	1/2 - 13 UNC		2	1/2 - 13 UNC		HEX JAM NUT
27	2	400-070		2	400-070		2	400-070		2	400-070		SPRING - PIVOT
28	4	3/8 WASHER		4	3/8 WASHER		4	3/8 WASHER		4	3/8 WASHER		STANDARD WASHER
29	4	5/16 WASHER		4	5/16 WASHER		4	5/16 WASHER		4	5/16 WASHER		STANDARD WASHER
30	6	#10 WASHER		6	#10 WASHER		6	#10 WASHER		6	#10 WASHER		LOCK WASHER
31	2	90-093		2	100-093		2	100-093		2	120-093		EXTENSION - BRAKE ARM
32	2	5/8 WASHER		2	5/8 WASHER		2	5/8 WASHER		2	5/8 WASHER		STANDARD WASHER
33	2	#10-24 UNC X 0.5		2	#10-24 UNC X 0.5		2	#10-24 UNC X 0.5		2	#10-24 UNC X 0.5		SCREW, SLOTTED PAN HEAD
34	4	1/4 - 20 UNC X 2.75		4	1/4 - 20 UNC X 2.75		4	1/4 - 20 UNC X 2.75		4	1/4 - 20 UNC X 2.75		SOCKET HEAD CAP SCREW
35	4	1/4 - 20 UNC		4	1/4 - 20 UNC		4	1/4 - 20 UNC		4	1/4 - 20 UNC		WHIZ NUT
36	1	102-091		1	102-091		1	102-091		1	102-091		MONITOR ASSEMBLY
		102-092			102-092			102-092			102-092		MONITOR ASSEMBLY - GOLD CONTACTS

BRAKE MONITOR SCHEMATIC AND WORKING PROCEDURE:

WARNING: IN ORDER TO DETECT A BRAKE FAILURE, THIS BRAKE MONITOR SWITCH MUST BE PROPERLY ADJUSTED & FULLY OPERATIONAL PRIOR TO BEING PLACED INTO SERVICE.

IMPORTANT: READ ENTIRE INSTRUCTIONS BEFORE ATTEMPTING ADJUSTMENT!!!

▲WARNING

SHOCK WARNING: ACTIVE ELECTRIC CIRCUITS!!

HOLLISTER-WHITNEY ELEVATOR CORP.

BRAKE MONITOR STANDARD WIRING SCHEMATIC

LABEL-0132N

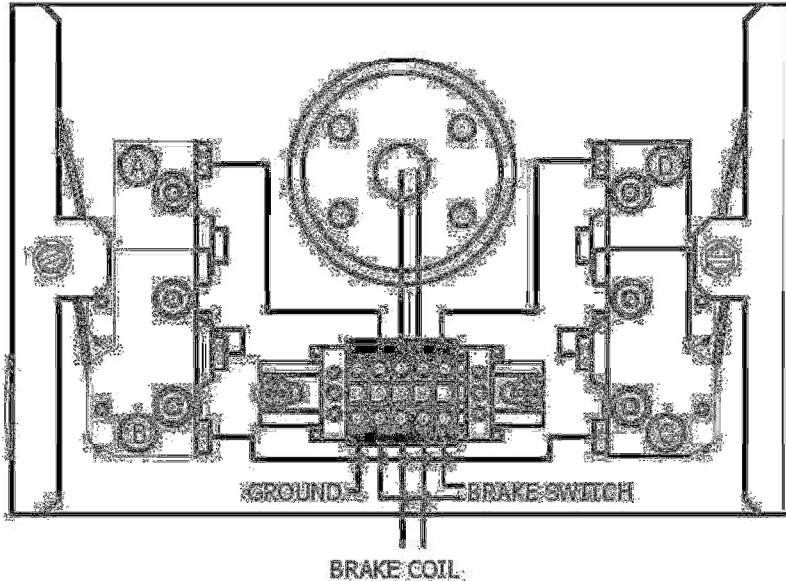

BRAKE MONITOR ASSEMBLY 102-091

NORMAL BRAKE DE-ENERGIZED
ALL CONTACTS ARE MADE
CIRCUIT CLOSED BETWEEN BM1 & BM2

NORMAL BRAKE ENERGIZED
CONTACTS A & D OPEN
OPEN CIRCUIT BETWEEN BM1 & BM2

BRAKE FAILURE APPROXIMATELY 1/2 INCH
TOO HIGH
CONTACTS A OR D OR BOTH FAIL TO CLOSE

EXCESSIVE BRAKE WEAR OR EXCESSIVE
TIRUS BEARING CLEARANCE
CONTACTS A OR D OR BOTH OPEN

BRAKE FAIL TO LIFT
CONTACTS A OR D OR BOTH FAIL TO OPEN

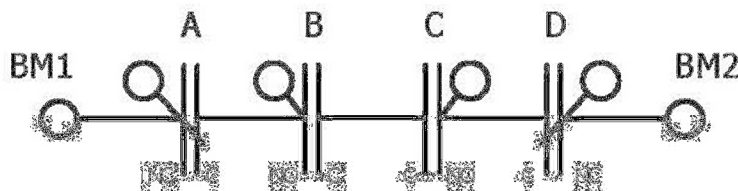

BRAKE MONITOR ADJUSTMENT:

1. Adjust top bolt "in" until you hear micro switch "click".
2. Rotate top bolt "in" 1 full revolution then tighten jamb nut against extension arm.
3. Adjust bottom bolt "in" until you hear micro switch "click".
4. Rotate bottom bolt "out" until you hear micro switch "click"
5. Rotate bottom bolt "out" 1 full revolution then tighten jamb nut against extension arm.
6. Repeat steps 1 thru 5 on opposite side of monitor.
7. Cycle Brake – check for micro switch activation and circuits are performing as designed.
8. Run machine and check adjustment when machine is at operating temperature.
9. Fine tuning may be needed per bolt until proper adjustment is obtained.

BOLT ADJUSTMENT DIRECTIONS

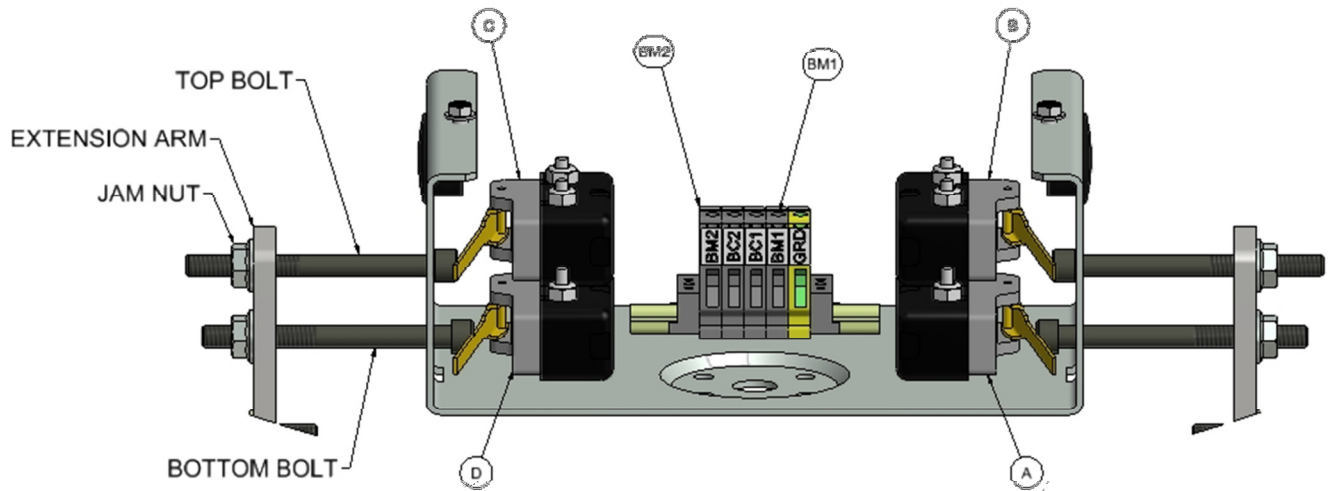

BRAKE FAILURE: DO NOT RE-ADJUST THE BRAKE MONITOR SWITCH UNTIL THE BRAKE PROBLEM HAS BEEN CORRECTED AND THE BRAKE RE-ADJUSTED.

- a.) If both contacts A and D fail to open with Brake energized, failure indicates improper pick up which can cause lining wear. Re-check Brake voltages, air gaps, alignment and freedom of arm and plunger movement, etc. To test this failure, place a jumper across terminals BM1 and BM2. The controls should remove the elevator from service in some fashion (See Suggested Operation on Page #8).
- b.) If contact A or D stays opened when Brake drops, failure indicates improper drop out caused by a bind (find bind and correct) or by excessive worm shaft movement (check thrust bearings etc.). To test, hold open contacts A or D, when elevator stops it should not be able to start (See Suggested Operation on Page #8).
- c.) If contacts B or C open when Brake drops, this indicates either worm shaft movement (check thrust bearings, etc.) or brake lining wear. If cause is normal lining wear, re-adjust Brake including spring tension, air gap, and centering screws, then re-adjust Brake Monitor Switch. To test open contacts B or C. Elevator should not be able to start (See Suggested Operation on Page #8).

NOTE: BRAKES MUST BE INSPECTED DURING NORMAL ELEVATOR MAINTENANCE. IF LININGS INDICATE WEAR, THEN SPRINGS, GAPS AND MONITOR SWITCH MUST BE RE-ADJUSTED ACCORDINGLY.

ANY ADJUSTMENT MADE TO THE BRAKE MIGHT AFFECT BRAKE MONITOR ADJUSTMENT.

Coils for #90, #100 & #110 Drum Brake

- 1) Constant 230 VDC, 0.82 A, 280 OHM or Step Down 250 V Pick, 150 V Hold
- 2) Constant 115 VDC, 1.16 A, 70 OHM or Step Down 125 V Pick, 75 V Hold

Coils for #120 Drum Brake

- 1) Constant 230 VDC, 0.74 A, 313 OHM or Step Down 250 V Pick, 150 V Hold
- 2) Constant 115 VDC, 1.38 A, 84 OHM or Step Down 250 V Pick, 150 V Hold

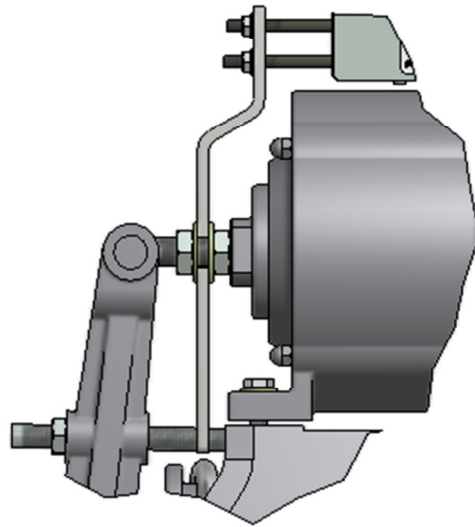

120 BRAKE
DETAIL A

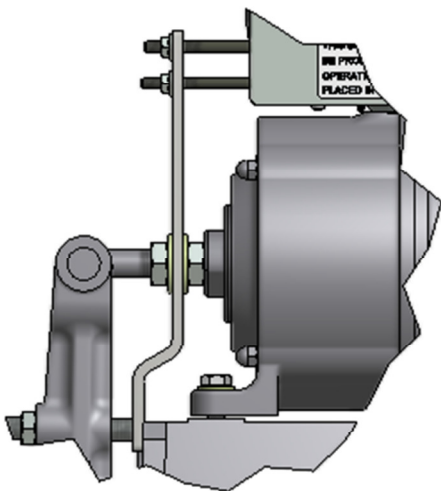

100 & 110 BRAKE
DETAIL A

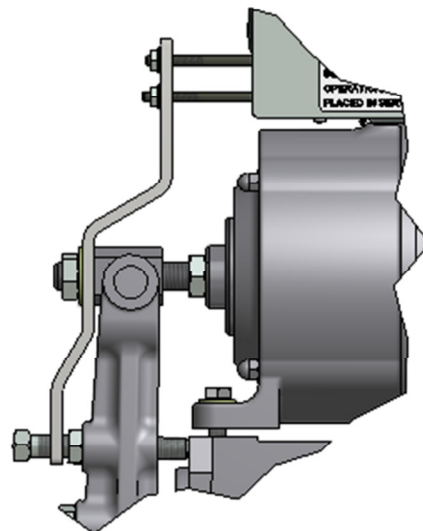

90 BRAKE
DETAIL A

Notes

Procedures

Date

Initials

Reference documentation can be found at <http://www.hollisterwhitney.com/#tech-support>

