

DIMENSIONS FOR OVERHEAD TRACTION MACHINES WITH RECTANGULAR BASEPLATE FOR ROPE GRIPPER MOUNTING

MACH.	BRAKE	A	B	C	D	E	F	G	H	J	K	L	M	N	P	Q	R (DIA.)	
																	MIN.	MAX.
#34 O.H.	#92 DISC	48	11	37	10 7/8	13 11/16	8	12	25 7/8	14 7/8	10	30 7/8	15 3/8	8 1/4	23 5/8	38 3/8	20	25
#44 O.H.	#102 DISC	60	15 1/2	44 1/2	13 7/8	17 9/16	10 3/4	15 5/16	23 7/8	16 7/8	6	28 7/8	20	10 3/4	30 3/4	37 7/8	20	28
#54 O.H.	#102 DISC	66	17 1/2	48 1/2	14 3/4	17 3/4	12 1/2	15 5/8	26 3/4	19 3/4	6	30 5/8	23 3/4	15 1/4	38 3/4	41 3/4	20	30
#64 O.H.	#112 DISC	72	20	52	18 3/8	19 7/8	13 3/8	17 5/8	33 1/4	24 1/4	8	34 1/2	25 1/2	16 1/8	41 5/8	51 1/4	25	36
#74 O.H.	#120 DRUM	84	20	64	19 5/16	24 3/4	18	23 3/4	40 13/16	29 13/16	10	46 5/8	31 3/4	16	47 3/4	59 13/16	32	38

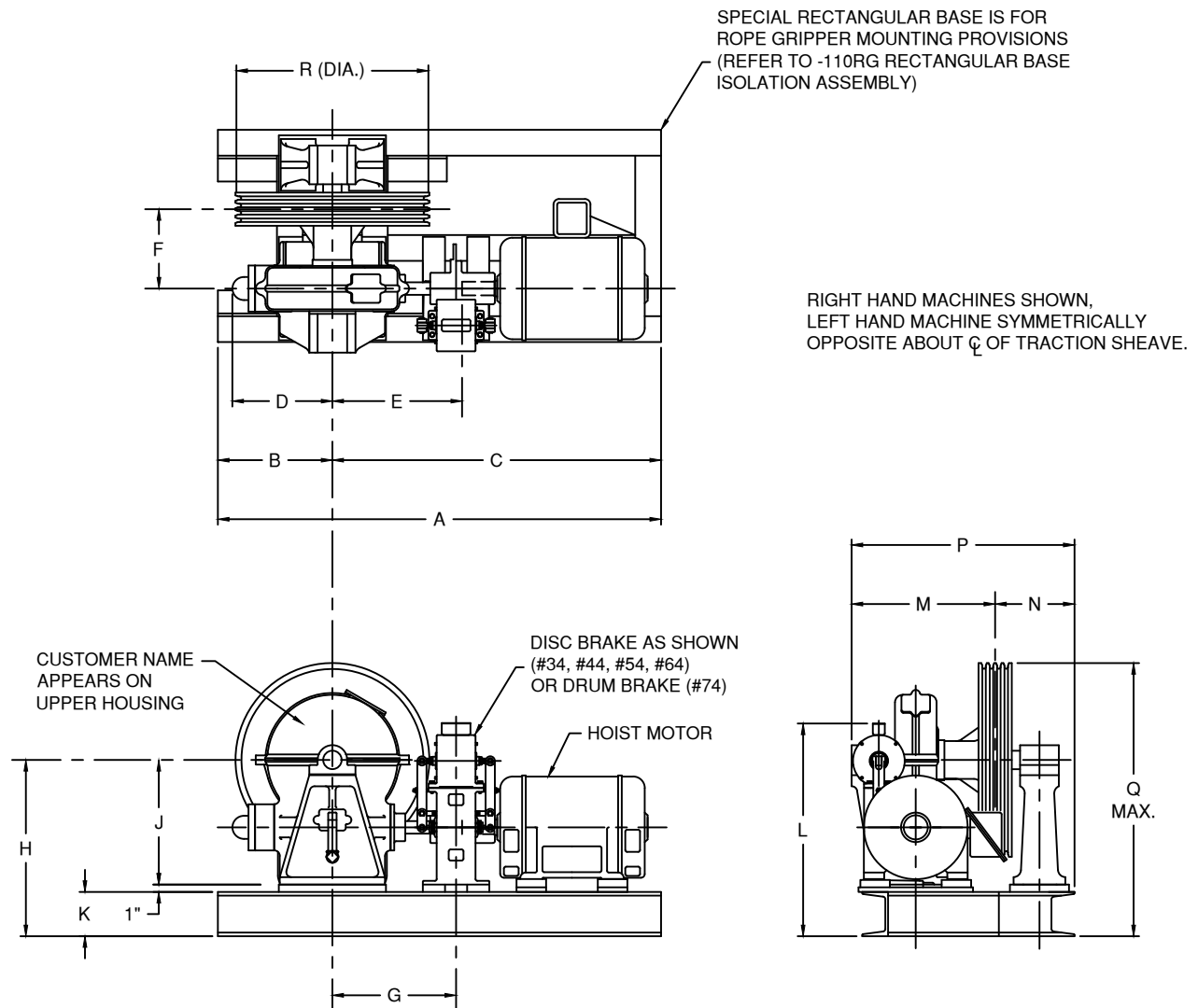

	10-22-2018
PUR 817	12-19-2016
PUR 739	11-12-2015
PUR 641	04-12-2014
	03-07-2013
	04-25-2011

 A VANTAGE Company	
OVERHEAD TRACTION MACHINES WITH RECTANGULAR BASEPLATE FOR ROPE GRIPPER MOUNTING	
DIMENSIONAL SHEET	1107-RG

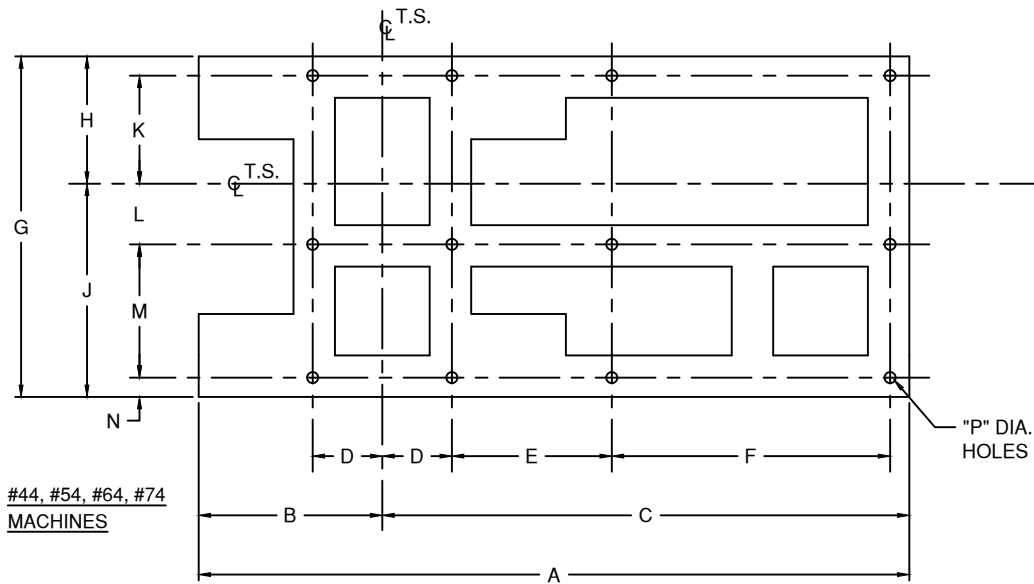

#44, #54, #64, #74
MACHINES

Right hand machine shown, left hand machine is symmetrically opposite about \bar{C} of traction sheave. Special rectangular base is required when rope gripper mounting provisions are included.

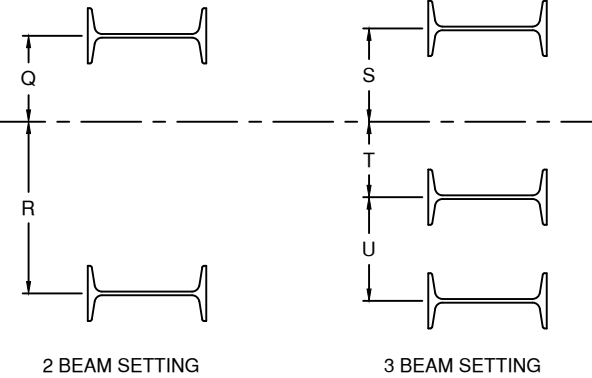

NOTE:
Views are showing top of baseplate. Holes are on bottom of baseplate.

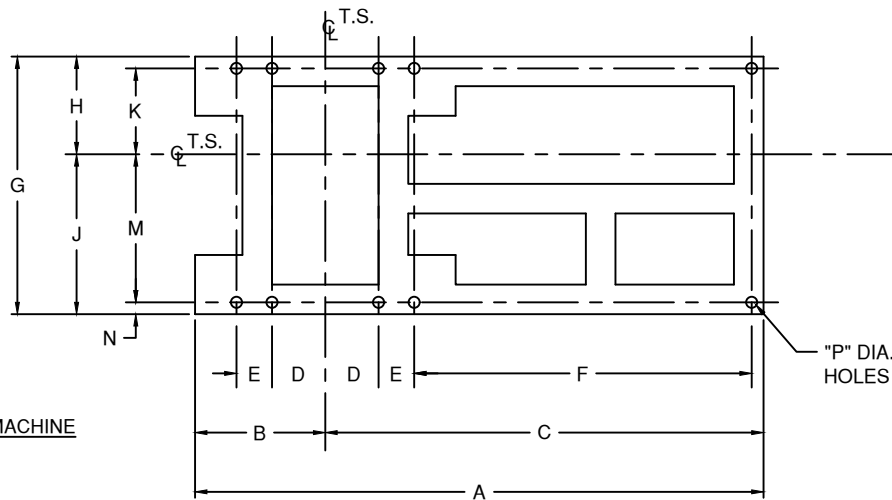

#34 MACHINE

Right hand machine shown, left hand machine is symmetrically opposite about \bar{C} of traction sheave. Special rectangular base is required when rope gripper mounting provisions are included.

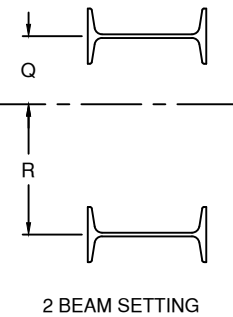

DIMENSIONS FOR OVERHEAD TRACTION MACHINES WITH RECTANGULAR BASEPLATE FOR ROPE GRIPPER MOUNTING

MACH.	A	B	C	D	E	F	G	H	J	K	L	M	N	P	Q	R	S	T	U
#34	48	11	37	4 1/2	3	28 1/2	21 3/4	8 1/4	13 1/2	7 1/4	6 1/8	12 1/2	1	15/16	5 3/4	11	-	-	-
#44	60	15 1/2	44 1/2	5 7/8	13 1/2	23 1/2	28 3/4	10 3/4	18	9 1/8	6 1/8	10 1/4	1 5/8	15/16	7 1/4	14 1/2	7 7/8	6 3/8	8 3/4
#54	66	17 1/2	48 1/2	7 7/8	19 1/2	19 1/2	36 5/8	15 1/4	21 3/8	13 5/8	6 1/4	13 1/2	1 5/8	15/16	11 1/2	18	11 7/8	7	11 1/2
#64	72	20	52	9 3/8	25 1/4	15 3/4	39 1/2	16 1/8	23 3/8	14 1/2	8 1/8	13 5/8	1 5/8	15/16	12 1/2	20	13	6 1/2	13 3/4
#74	84	20	64	10 1/4	25 3/4	26	45 1/2	16	29 1/2	14	10	17 1/2	2	15/16	-	-	12 1/4	10 1/4	15 1/2

BULLETIN 1107-RG

PUR 817	12-19-2016
PUR 739	11-12-2015
PUR 641	04-12-2014
	03-07-2013
	04-25-2011