



Hollister-Whitney Elevator Corporation

#1 Hollister-Whitney Parkway
Quincy, IL 62305
Phone: 217-222-0466

Fax: 217-222-0493
e-mail: info@hollisterwhitney.com
www.hollisterwhitney.com

GOVERNOR SHAFT CONVERSION

SECTION 1: List of Available Sheave/Shaft Assemblies

SECTION 2: Converting a 207-0.25 Governor to a 207-0.75

SECTION 3: Converting a 202-0.25 Governor to a 202-0.75

SECTION 4: Instructions to Set, Check, or Re-set Nameplate Electrical & Mechanical Trip Speeds for H-W Governor Assemblies

The Field Mechanic will be required to have normal Mechanics Tools on hand, as well as a brass or dead-blow hammer, drill with a 1/4" bit, and speed testing equipment. NOTE: Have on hand a convenient container for Small Parts.

SECTION 1: AVAILABLE SHEAVE/SHAFT ASSEMBLIES

SHEAVE/SHAFT PART #	GOVERNOR	SHEAVE SIZE	ROPING	ENCODER MOUNT SHAFT SIZE
207-200-0.25	207-0.25	12.5"	3/8"	1/4"
207-200-0.472	207-0.472	12.5"	3/8"	12 mm
207-200-0.75	207-0.75	12.5"	3/8"	3/4"
207-200-1.00	207-1.00	12.5"	3/8"	1"
202-202-0.25	202-0.25	16"	3/8"	1/4"
202-202-0.472	202-0.472	16"	3/8"	12 mm
202-202-0.75	202-0.75	16"	3/8"	3/4"
202-202-1.00	202-1.00	16"	3/8"	1"
202-226-0.25	202-0.25	16"	1/2"	1/4"
202-226-0.472	202-0.472	16"	1/2"	12 mm
202-226-0.75	202-0.75	16"	1/2"	3/4"
202-226-1.00	202-1.00	16"	1/2"	1"

Read and Understand all Instructions Prior to Governor Conversion.

SECTION 2: CONVERT A 207-0.25 GOVERNOR TO A 207-0.75

REQUIRED PER GOVERNOR: 1 Governor Sheave/Shaft Assembly, Example p/n 207-200-0.75, available from Hollister-Whitney.

Prior to Working on Governor, observe all safety precautions necessary for preventing car movement.

1. Block Up the Tension Weight to remove tension from the Governor Rope
2. Remove Encoder

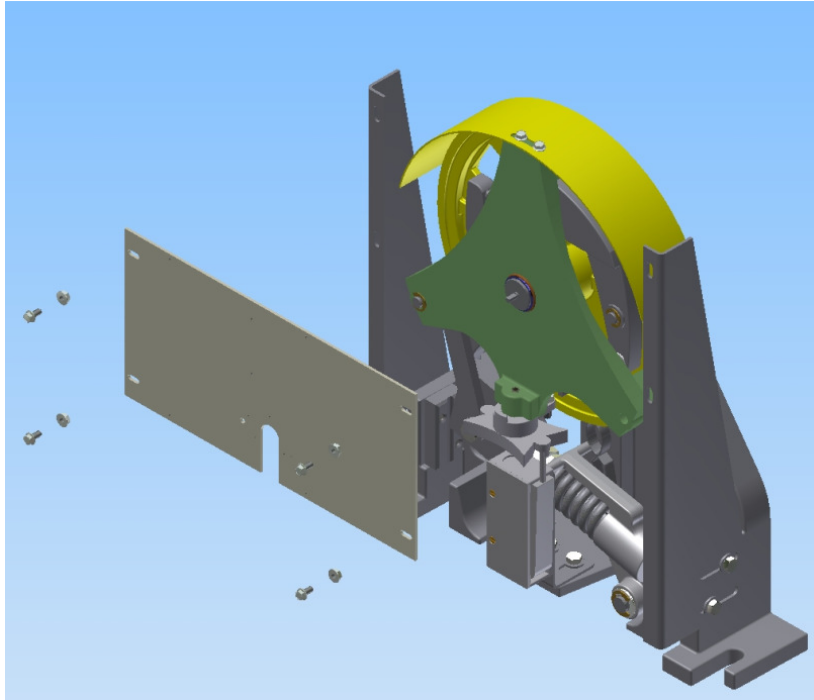

3. Remove front Encoder Bracket

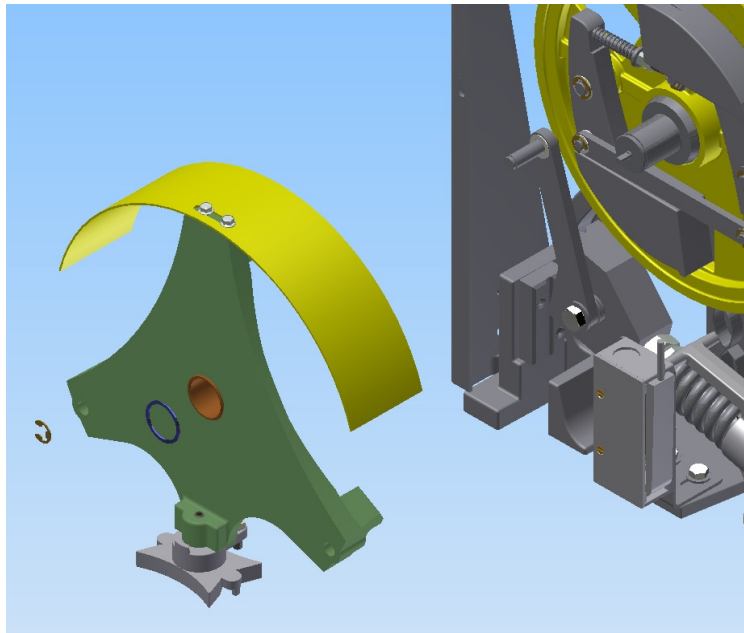

4. Remove E-clip from Link Pin, and Shaft Retaining Ring from Main Shaft and slip Yoke Assembly off Main Shaft. Slip Governor Rope off Sheave and secure it out of the way.

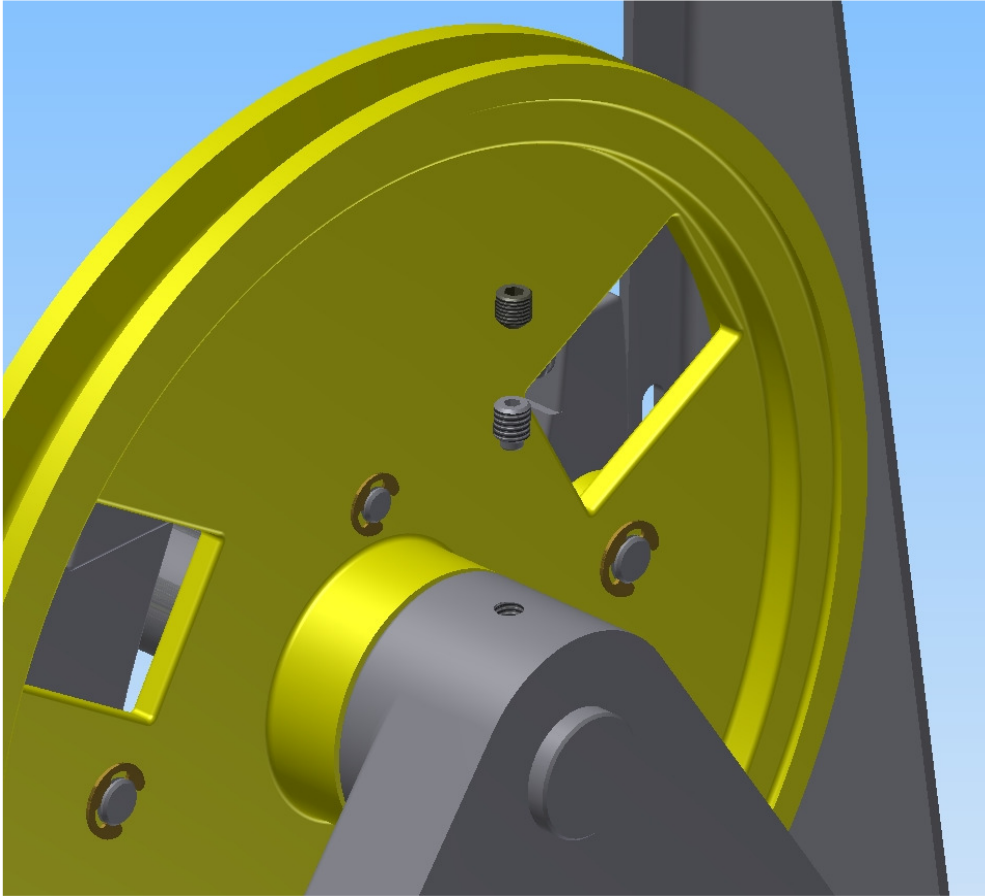

5. Remove two Set Screws (securing Main Shaft) from Governor Base.

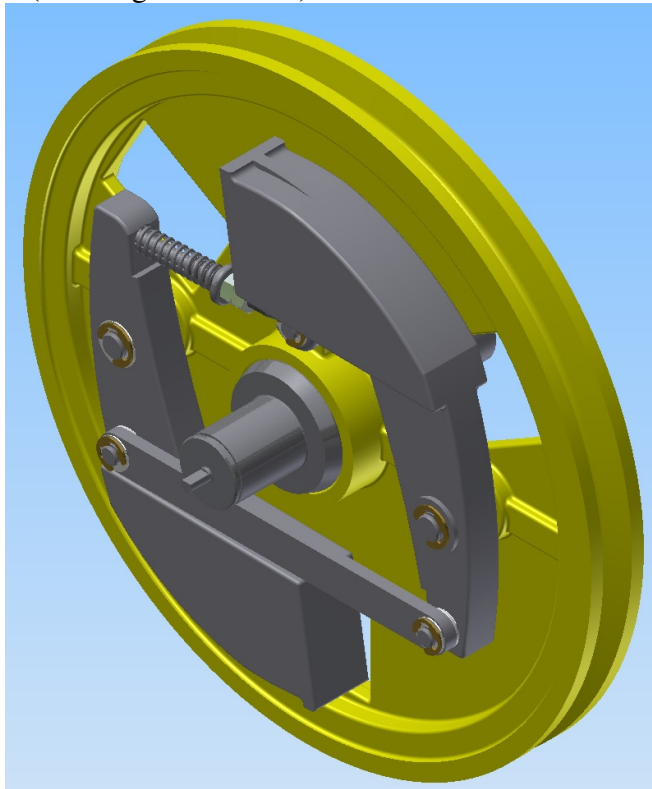

6. Using brass or dead-blow hammer, tap Main Shaft (Sheave/Shaft Assembly) out of Governor Base, and transfer the Sheave/Shaft Assembly to a convenient work table.

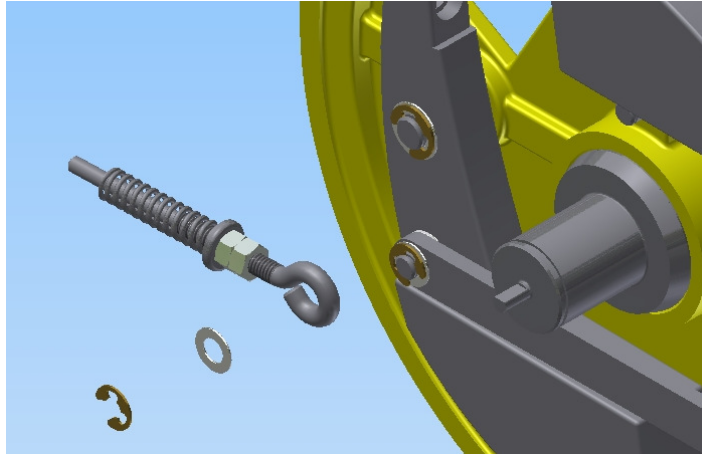

7. Remove E-clip from Tripping Spring Pin, remove Spring/Eyebolt Assembly, noting washer location.

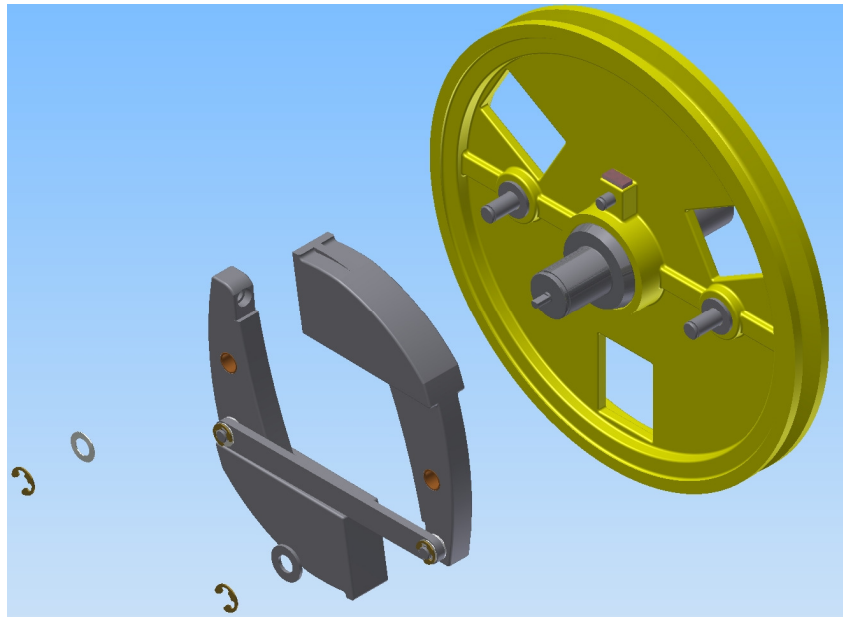

8. Mark Front of Pawl (fly-weight) Assembly to help with later re-assembly. Remove 2 E-clips from Pawl Pivot Pins. Again note number of washers between E-clip and Pawl. Remove the Pawl Assembly as a Unit. Remove also Washers between Pawls and Sheave.
9. Extra Washers and E-clips are provided. In Reverse Order, re-assemble Pawl and Spring Assemblies to the new 207-200-0.75 Sheave/Shaft Assembly, taking note of the washer spacing. Pawls should be free to rotate on the pins without dragging on the sheave, nor binding due to tight (too many) washers.
10. It may be necessary to remove burrs inside the Governor Base (Main Shaft Bore) prior to proceeding.
11. Slip the Sheave/Shaft Assembly partially into the Governor Base. Place Provided 0.010" Shim over Shaft between Sheave and Base. Slide Sheave/Shaft Assembly fully into place.
12. Using Center Punch or similar Marking Method, through Set Screw hole in top of Governor Base, mark the center location on the shaft.
13. Remove Sheave/Shaft Assembly. At Center Punch Mark, using drill and 1/4" drill bit, drill into the main shaft approximately 1/16" to 1/8" deep. This is simply a point to help lock the shaft in place using the set screws. Remove any burrs raised by the drill bit.

14. With 0.010" shim re-assemble the Sheave/Shaft Assembly into the base and lock in place with the 2 set screws. REMOVE SHIM.
15. Complete re-assembly and re-test Speeds. See **Section 4** Instructions Below. A small Drill Bit and Seal have been included should Speed Adjustments become necessary.

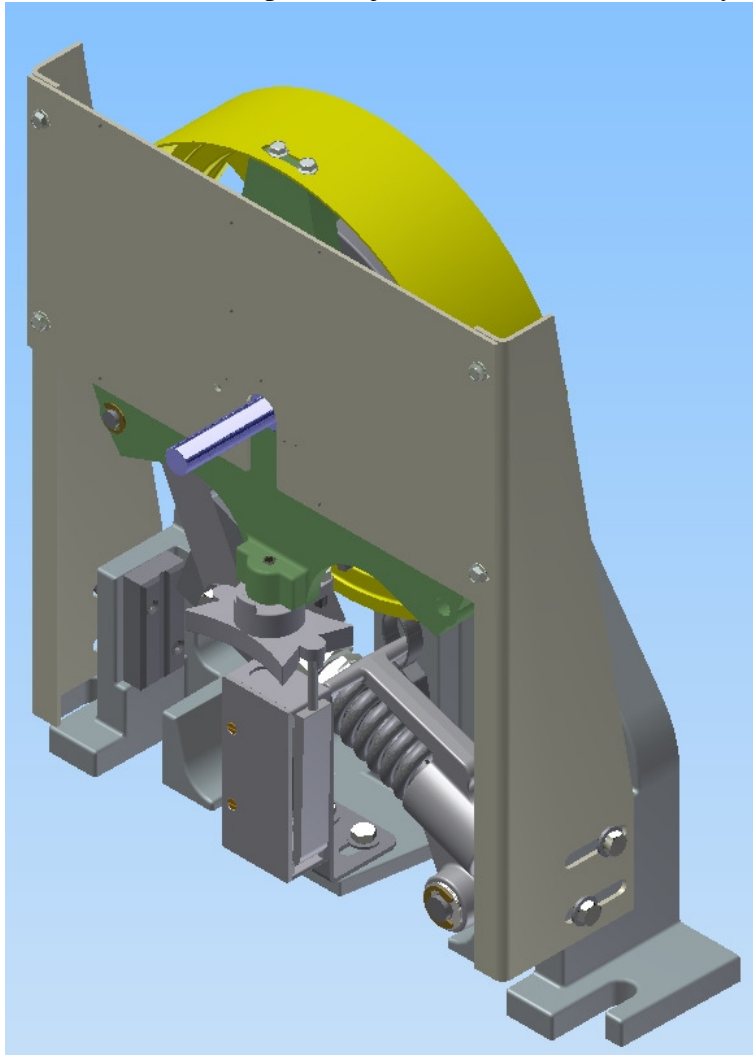

SECTION 3: CONVERT A 202-0.25 GOVERNOR TO A 202-0.75

REQUIRED PER GOVERNOR: 1 Governor Sheave/Shaft Assembly, Example p/n 202-226-0.75, available from Hollister-Whitney. NOTE: Confirm Governor Rope Size and compare to Part Numbers in Section 1. 202 Sheave Assembly part numbers vary with Governor Rope Size.

Prior to Working on Governor, observe all safety precautions necessary for preventing car movement.

1. Block Up the Tension Weight to remove tension from the Governor Rope
2. Remove Encoder

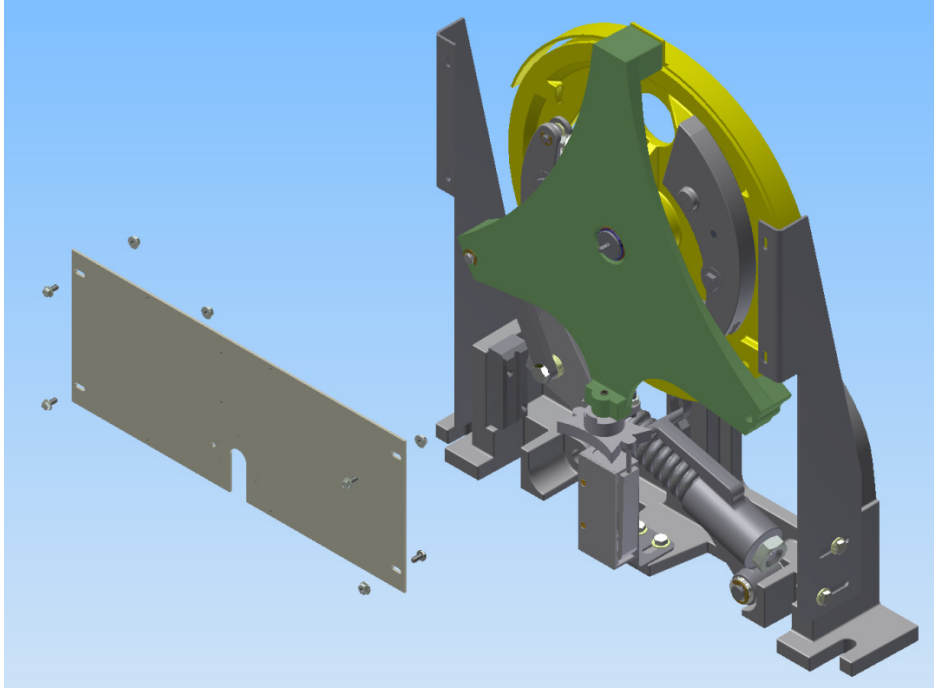

3. Remove front Encoder Bracket

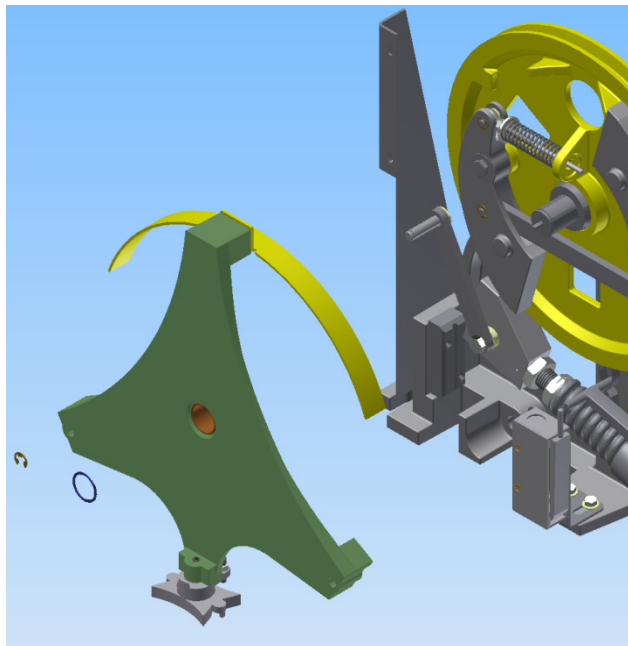

4. Remove E-clip from Link Pin, and Shaft Retaining Ring from Main Shaft and slip Yoke Assembly off Main Shaft. Slip Governor Rope off Sheave and secure it out of the way.

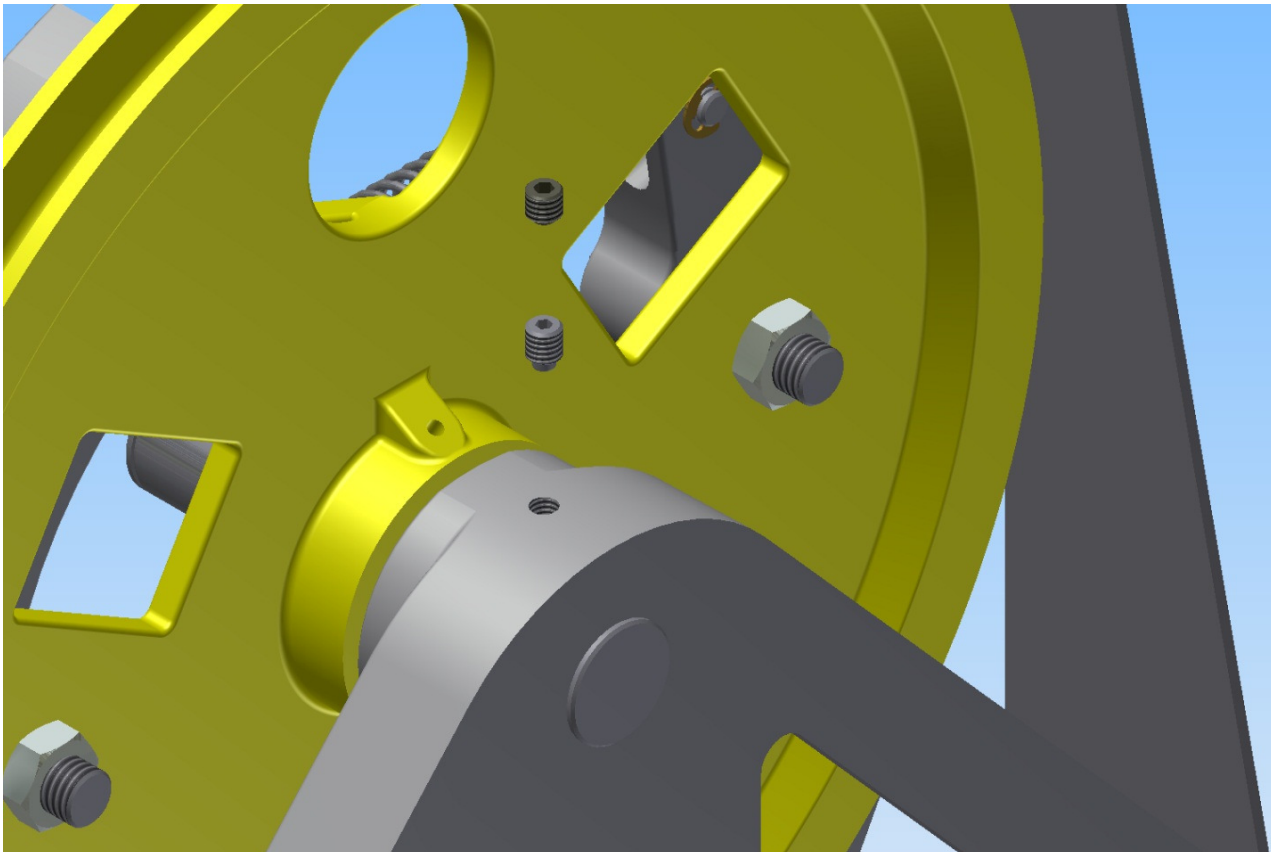

5. Remove two Set Screws (securing Main Shaft) from Governor Base.

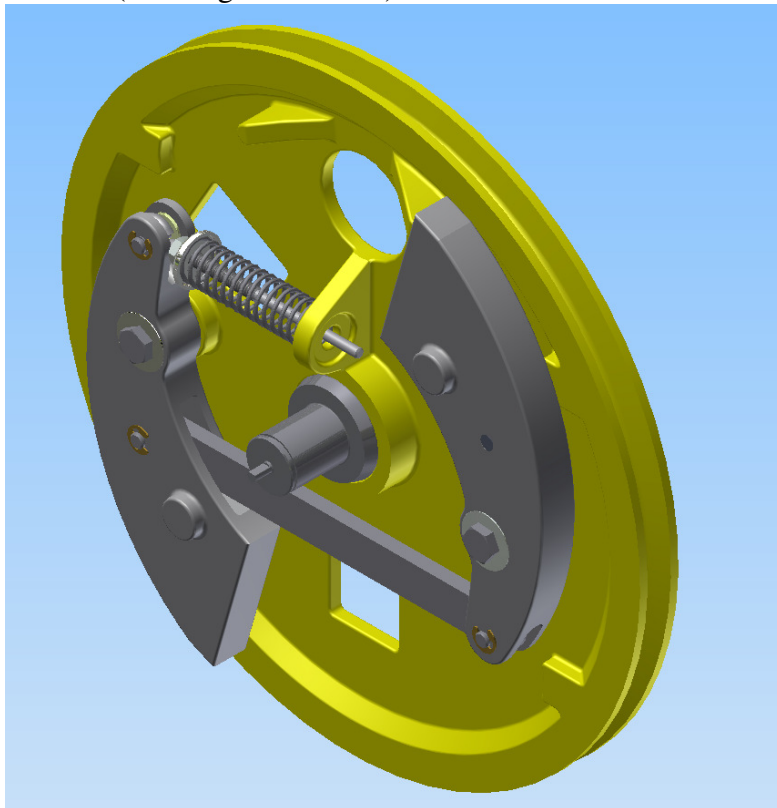

6. Using brass or dead-blow hammer, tap Main Shaft (Sheave/Shaft Assembly) out of Governor Base, and transfer the Sheave/Shaft assembly to a convenient work table.

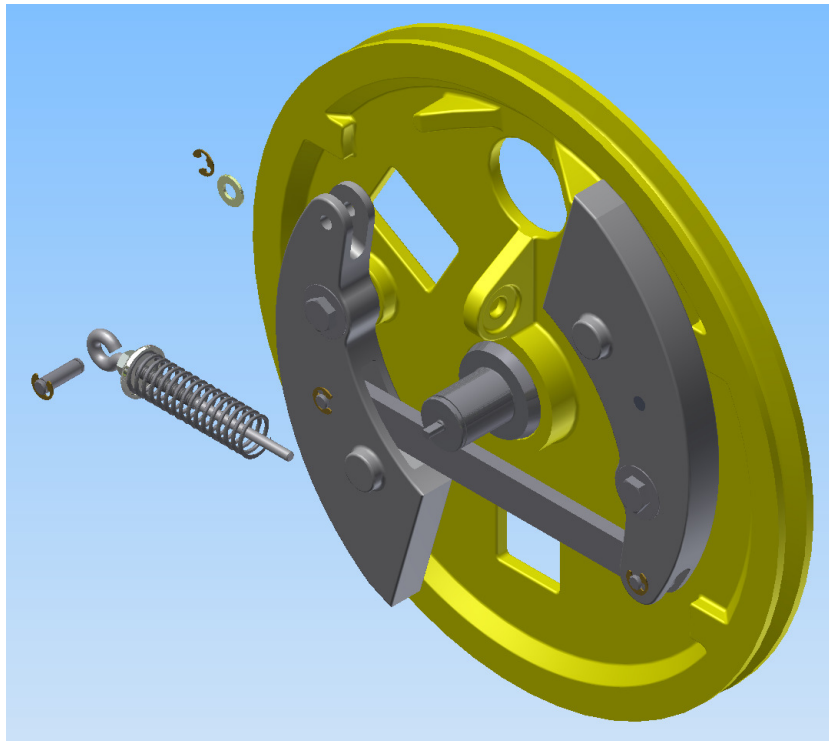

7. Remove E-clip (back of the Pawl (fly-weight)) from Tripping Spring Pin; remove Spring/Eyebolt Assembly, noting washer location.

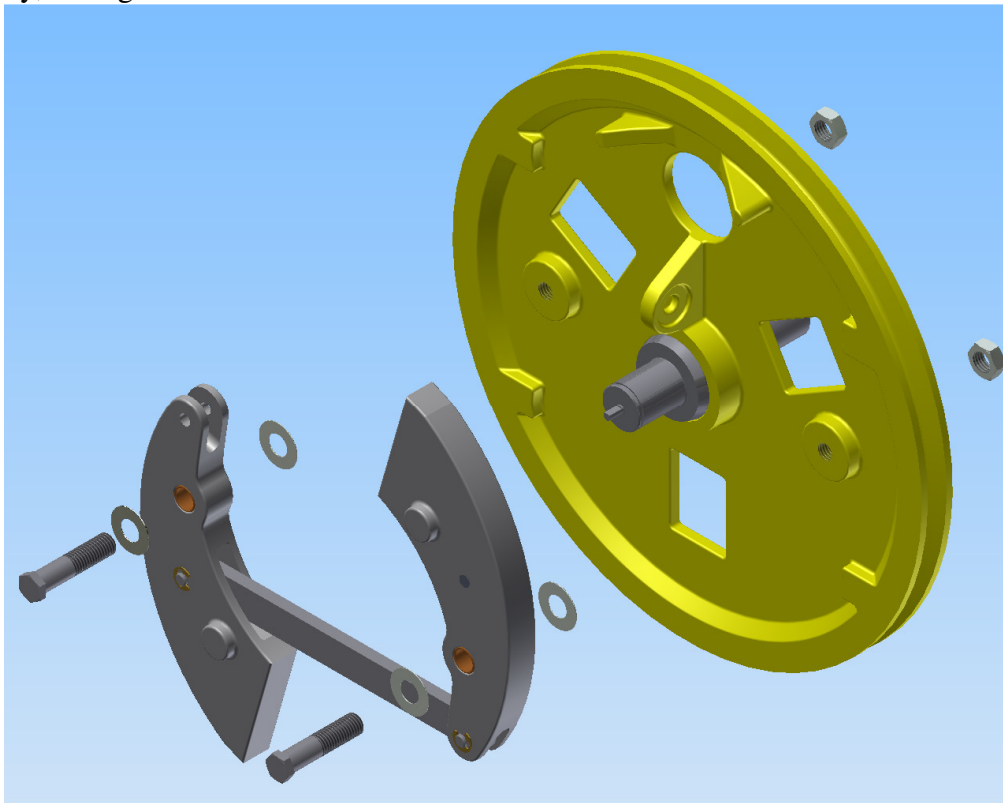

8. Mark Front of Pawl (fly-weight) Assembly to help with later re-assembly. Remove 2 Jam Nuts from back of Sheave/Shaft Assembly and remove (unscrew) Pawl Pivot Bolts. Again note number and location of washers on Pivot Bolt and Pawl. Remove the Pawl Assembly as a Unit. Remove also Washers between Pawls and Sheave.

9. In Reverse Order, re-assemble Pawl and Spring Assemblies to the new 202-226-0.75 Sheave/Shaft Assembly, taking note of washer spacing. When re-assembling Pivot Bolts, Pawls should be free to rotate on the bolts without dragging on the sheave, nor binding due to tight bolt or washers. If too tight, back off Pivot Bolts about 1/8 (no more than to 1/4) turn Tighten Jam Nuts re-check "free" play of Pawls.
10. It may be necessary to remove burrs inside the Governor Base (Main Shaft Bore) prior to proceeding.
11. Slip the Sheave/Shaft Assembly partially into the Governor Base. Place Provided 0.010" Shim over Shaft between Sheave and Base. Slide Sheave/Shaft Assembly fully into place.
12. Using Center Punch or similar Marking Method, through Set Screw hole in top of Governor Base, mark the center location on the shaft.
13. Remove Sheave/Shaft Assembly. At Center Punch Mark, using drill and 1/4" drill bit, drill into the main shaft approximately 1/16" to 1/8" deep. This is simply a point to help lock the shaft in place using the set screws. Remove any burrs raised by the drill bit.
14. With 0.010" shim re-assemble the Sheave/Shaft Assembly into the base and lock in place with the 2 set screws. REMOVE SHIM.
15. Complete re-assembly and re-test Speeds. See **Section 4** Instructions Below. A small Drill Bit and Seal have been included should Speed Adjustments become necessary.

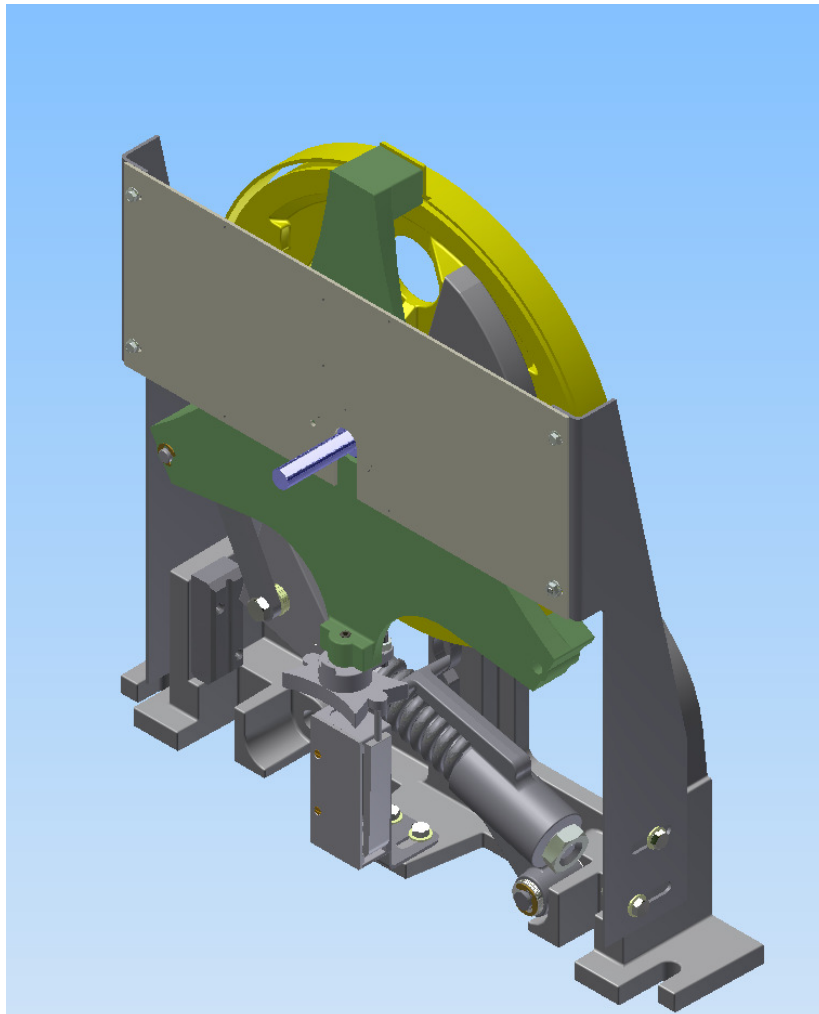

SECTION 4

INSTRUCTIONS TO SET, CHECK, OR RE-SET NAMEPLATE ELECTRICAL & MECHANICAL TRIP SPEEDS FOR H-W GOVERNOR ASSEMBLIES

See also E-Document E-140 at:

<http://www.hollisterwhitney.com/#tech-support>

CHECKING GOVERNOR SPEED

Check Mechanical Speed First.

Run Hand Tachometer Wheel on Governor and spin Governor with a wheel on a variable speed drill motor and match the Tachometer Reading with one of the following methods:

1. With hand tachometer in **bottom** of Governor Groove, multiply Name Plate Value by number called out in the table below; Example use 0.97 for 207 Governor. This Calculated Value will be Lower than Name Plate Value. Or;
2. With hand tachometer on **outside rim** of Governor Sheave, multiply Name Plate Value by number called out in the table below; Example use 1.08 for 207 Governor. This Calculated Value will be Higher than Name Plate Value.

GOVERNOR	SHEAVE SIZE	ROPING	In Groove Bottom	On Outside Rim
207	12.5"	3/8"	0.97	1.08
202	16"	3/8"	0.97	1.0625
202	16"	1/2"	0.977	1.0625

Mechanical Trip Speed **Must Be Confirmed** prior to Electrical.

IF ADJUSTMENT IS REQUIRED

- Remove the Seal on the Spring/Eyebolt Assembly that connects one Pawl to the Sheave.
- Adjust the Spring to Correct the Mechanical Trip Speed
- After the Mechanical Trip Speed is correct, re-adjust Bolt on Trigger to Correct Electrical Trip speed if required.
- Reseal the Spring/Eyebolt Assembly.