 A VANTAGE Company	Document Name	Date	Rev.	Page	Bulletin
	Setting Rope Gripper Trigger Release Pressure	8/17/20	C	1 of 5	1164

SETTING ROPE GRIPPER® TRIGGER RELEASE PRESSURE AND CONFIRMING ELECTRICAL CONNECTIONS

Tools Required:

- 5/32" Allen Wrench
- 3/8" Open End Wrench
- Flat bladed Screwdriver
- 30 pound (minimum) Door Pressure Scale
- Small Metal File

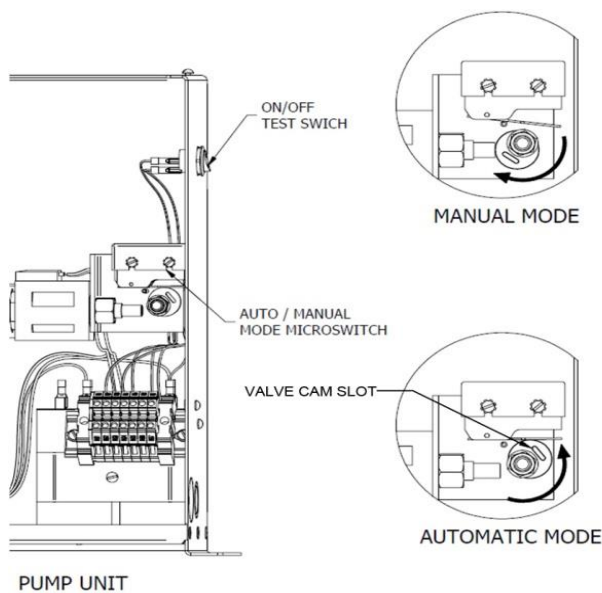

Figure 1: Test Switch Valve Stem and Cam Location

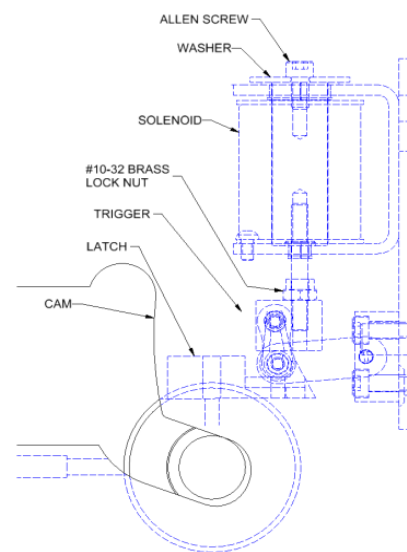

Figure 2: Latch and Latching Coil

Caution: Keep fingers and hands clear of Rope Gripper®, forces created can crush fingers.

1. Refer to Figures 1 and 2 for location of Rope Gripper® parts. Place Elevator on Inspection and turn test (power) switch “OFF”.
2. Check for burrs on the edges of the latch and lightly file with small file if necessary (see Figure 3).
3. Turn the Rope Gripper® test switch to “ON” so that the Gripper® opens fully (reloads) and is not touching the hoist cables.
4. With a flat bladed screwdriver placed in the slot of the valve cam, turn the cam clockwise to fully close the valve (Manual Mode, see Figure 1 & 4).
5. To adjust the valve to the slowest possible pressure relief (drop-out) speed, turn the Gripper® test switch “OFF” and slightly turn the valve cam counterclockwise (maintain contact with the valve stem) until the trigger unit moves slowly past the latch to the clamped (on hoist ropes) position. Turn the test switch “ON” and repeat this procedure to get the slowest possible drop-out speed.
6. When slow drop-out speed is achieved, remove screwdriver. Leave cam in this position until procedure is completed and trigger pressure is properly set.

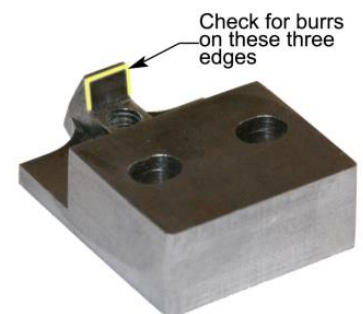



Figure 3: Inspect Latch Edges

	Document Name	Date	Rev.	Page	Bulletin
	Setting Rope Gripper Trigger Release Pressure	8/17/20	C	2 of 5	1164

7. Turn test switch “ON”. With Rope Gripper® energized, apply Pressure Scale to Allen Screw on top of trigger solenoid with 25 pounds of force (See Figure 5). Turn test switch “OFF” while holding the 25 pounds of force.
8. Slowly reduce the pressure on the Pressure Scale from 25 pounds and observe the pressure at the point where the trigger assembly releases. **Note this pressure.** The correct release pressure should be from 15 to 17 pounds.
9. If pressure is not correct, place the Allen wrench in the Allen Screw on top of solenoid and loosen (turn counterclockwise) the #10-32 brass locking nut on bottom of solenoid armature (see Figure 6) with a 3/8” open end wrench while holding the Allen Screw steady.
10. With nut is loose, now adjust the Allen Screw on top of solenoid (clockwise to increase or counterclockwise to decrease) the Gripper® release pressure. Adjust by turning Allen Screw ½ turn at a time (see Figure 6).
11. While holding the Allen Screw, now tighten the #10-32 brass locking nut (**Caution: Do not over tighten as it may strip threads**) steady and repeat steps 7 thru 10 as needed, until correct release pressure of 15 to 17 pounds is obtained.
12. Do not adjust the valve. Turn test switch “OFF”. Remove dump valve coil wire from top of terminal RG3 in Pumping Unit and retighten the terminal. Put dump valve coil wire into RG4 with existing wires and retighten top of Terminal Strip. (See Figure 7)
13. Turn the test switch “ON”. The Rope Gripper® should open and stay latched.
 - a. If the Gripper® cycles (doesn’t stay latched), contact Hollister-Whitney.
 - b. If the Gripper® does not cycle (stays latched), turn test switch “OFF” and return dump valve coil wire to RG3. (See Figure 8) Confirm all terminals are tight. Continue to Step 14.



Figure 4: Turn Cam to Manual Mode

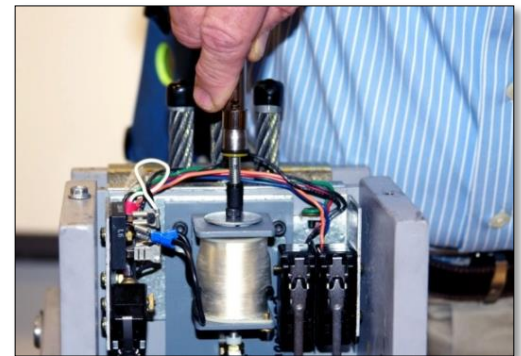

Figure 5: Apply Pressure Scale



Figure 6: Brass Nut & Allen Screw Location

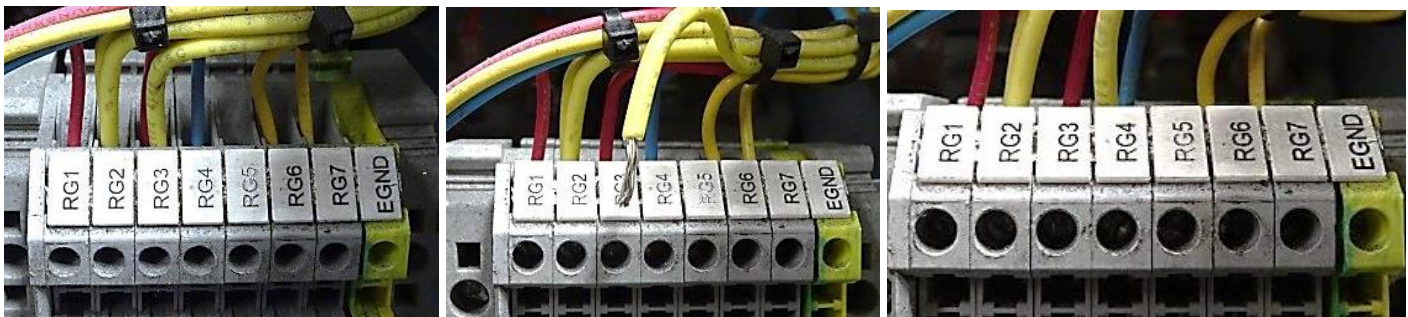



Figure 7: Move Dump Valve Coil Wire from RG3 to RG4

 A VANTAGE Company	Document Name	Date	Rev.	Page	Bulletin
	Setting Rope Gripper Trigger Release Pressure	8/17/20	C	3 of 5	1164

14. Turn the test switch “ON” and turn the valve cam counterclockwise to actuate the “Auto/Manual Mode Micro Switch” in the auto position (Automatic Mode, see Figure 1).
15. Turn test switch “OFF” to activate Gripper®. Gripper® should clamp hoist ropes. Turn Gripper® test switch “ON”. Gripper® should reload to the ready position. Return Elevator to Service.

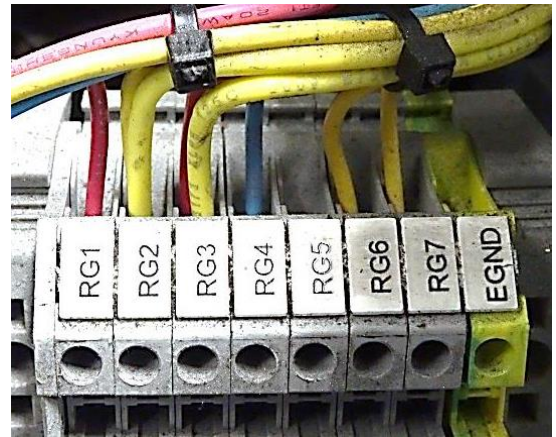

Figure 8: Terminal Block Wiring, Return Valve Coil Wire to RG3

Additional Information

1. For complete Rope Gripper® Manual, **Bulletin 1144**, go to: <http://www.hollisterwhitney.com/support/>
2. Pictures in this instruction were taken using older generation Rope Gripper®. Switch arrangements may differ on current generation Rope Gripper® (see Figure 9).

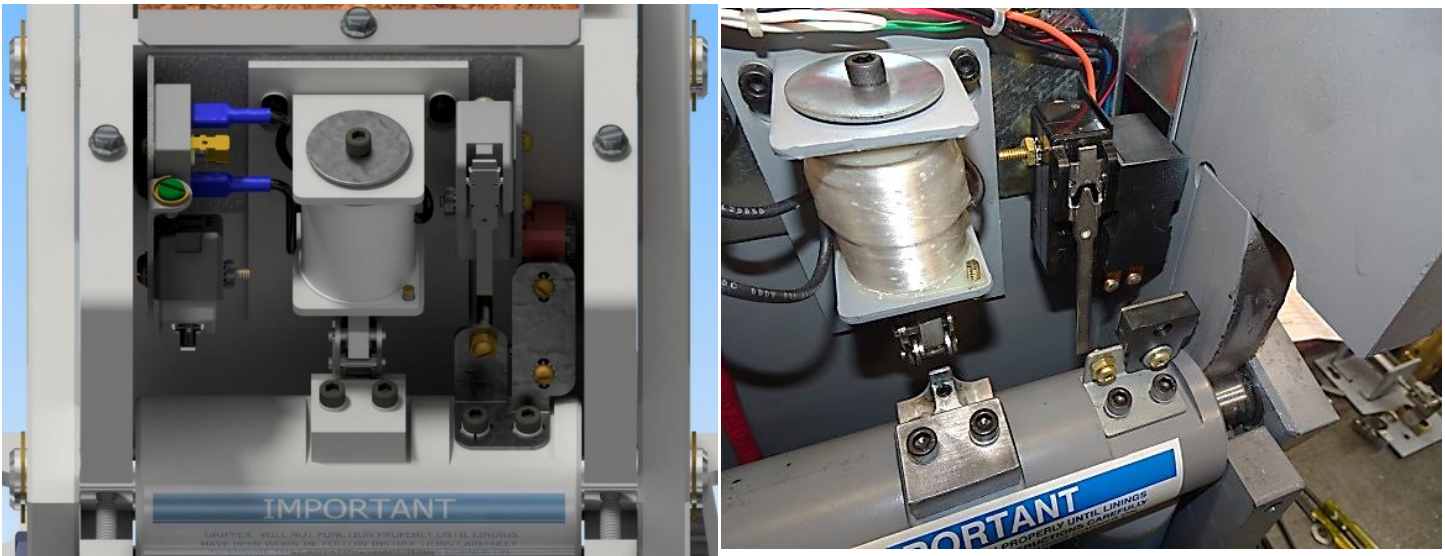

Figure 9: Left Hand picture shows latest generation of Rope Gripper® Microswitch Arrangement. Replaces the last generation shown on Right. Pictures for illustration purposes only.

3. ELECTRICAL CONNECTION VERIFICATION – (see Figure 10) The wiring of the controls to the pump unit should be as per the control manufacturers’ diagrams, with wires from the control to terminals RG1, RG2, RG5, RG7 and ground terminal EGND. Wires from the Gripper® to the pump unit are color coded and should be checked and correctly wired as:

White	---	RG2
Black	---	RG3
Red	---	RG4
Orange	---	RG5
Blue	---	RG6
Green/Yellow	---	EGND



A VANTAGE Company

Document Name	Date	Rev.	Page	Bulletin
Setting Rope Gripper Trigger Release Pressure	8/17/20	C	4 of 5	1164

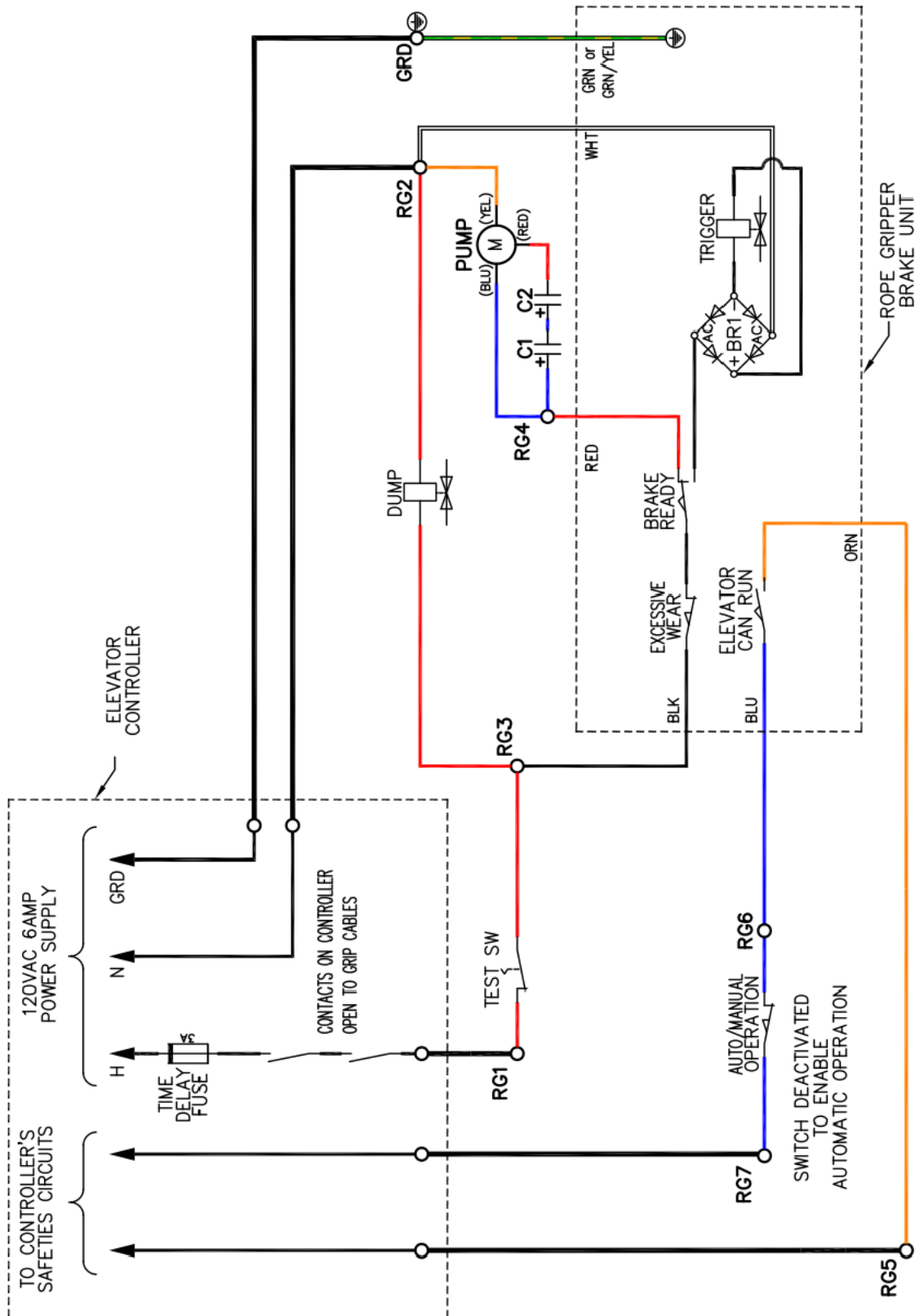

Figure 10: Rope Gripper® Electrical Schematic – Current Configuration; Switch DEACTIVATED to Enable Automatic Operation



Document Name	Date	Rev.	Page	Bulletin
Setting Rope Gripper Trigger Release Pressure	8/17/20	C	5 of 5	1164

Hollister-Whitney
Elevator Co., LLC
2603 North 24th Street
Quincy, Illinois 62305
Phone: 217-222-0466
Fax: 217-222-0493

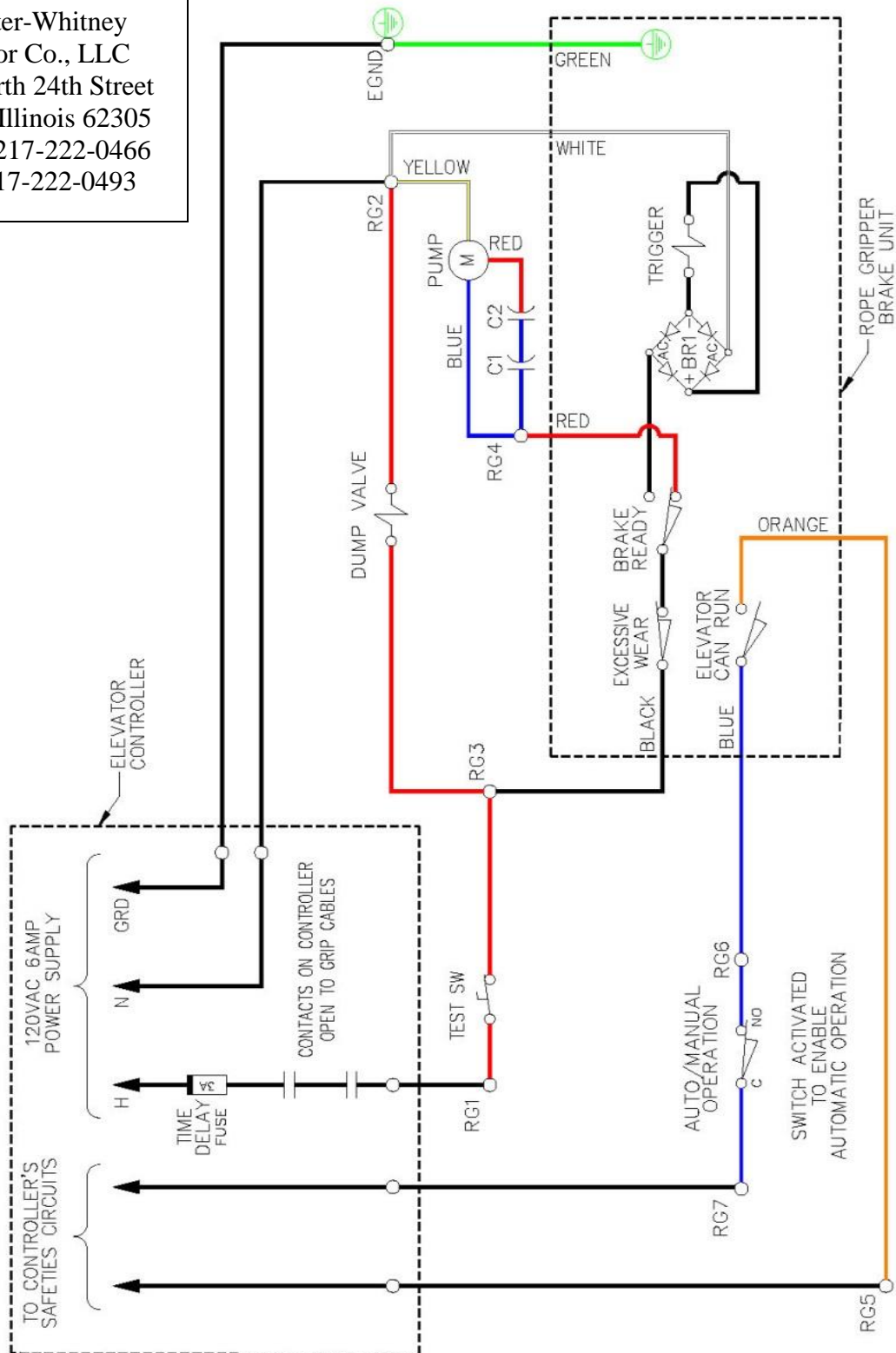

Figure 11: Rope Gripper® Electrical Schematic – Past Configuration; Switch **ACTIVATED** to Enable Automatic Operation