

ENGINEERING CONTACT: _____
 COMPANY: _____
 EMAIL: _____
 FAX NO: _____

JOB NAME: _____
 ELEV. #: _____ H-W #: _____
 FROM (H-W): _____
 DATE: _____

**INFORMATION REQUIRED TO MANUFACTURE
 COUNTERWEIGHT FRAMES**

- CWT. RAIL SIZE (IN LBS) _____
- CWT. SHOE MANUFACTURER _____

COUNTERWEIGHT WITH SHEAVE

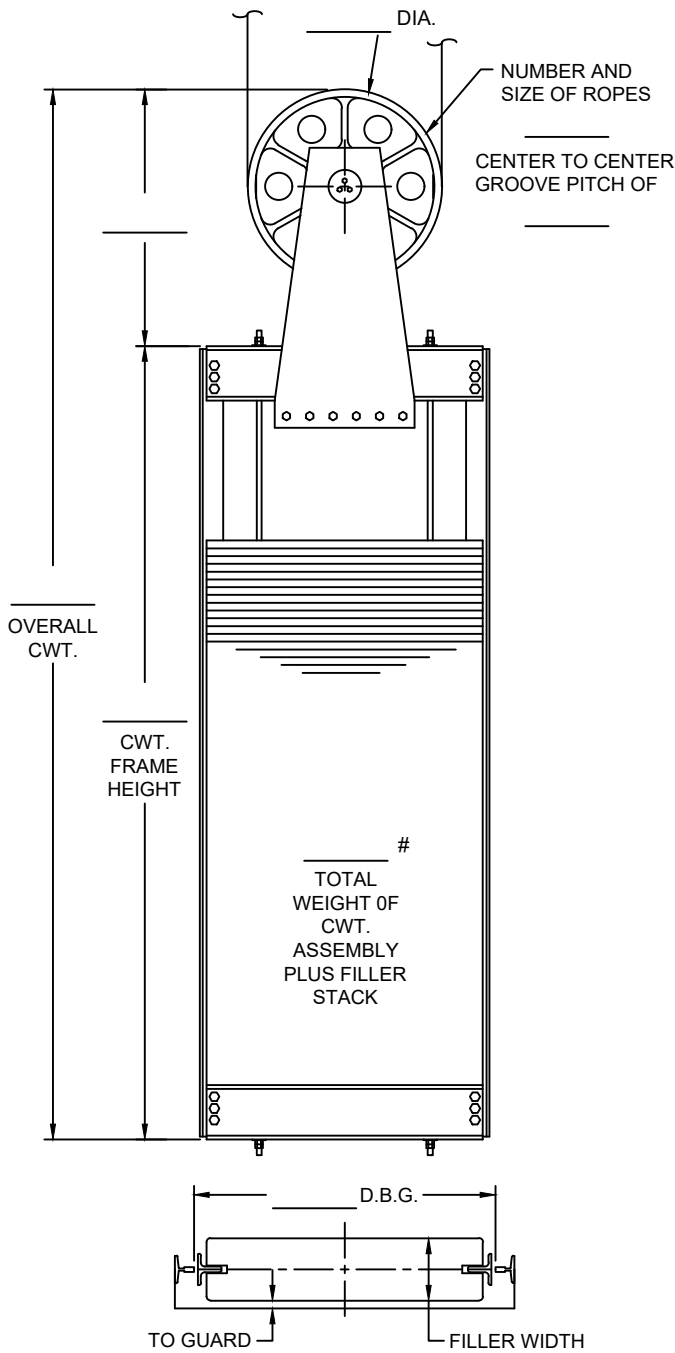

**ENGINEERING INFORMATION:
 WE REQUIRE ALL MARKED ITEMS
 AND FILL IN ANY BLANK FIELDS
 ASSOCIATED WITH THOSE ITEMS**

COUNTERWEIGHT WITHOUT SHEAVE

